

Oversized Secondary Pulley/Pressure Regulator Valve Kit

Part No.
33741F-01K



- Valve
- End Plug

NOTE: Also fits Mitsubishi FICJB.

Tool Kit



Part No.
F-33741F-TL

- Reamer
- Reamer Jig
- Guide Pin

NOTE: Sonnax “F-Tool” kits designed to service a specific bore require the VB-FIX, a self-aligning valve body reaming fixture. More information and instructions can be found online at www.sonnax.com.

Jatco/Nissan JF015E (RE0F11A)

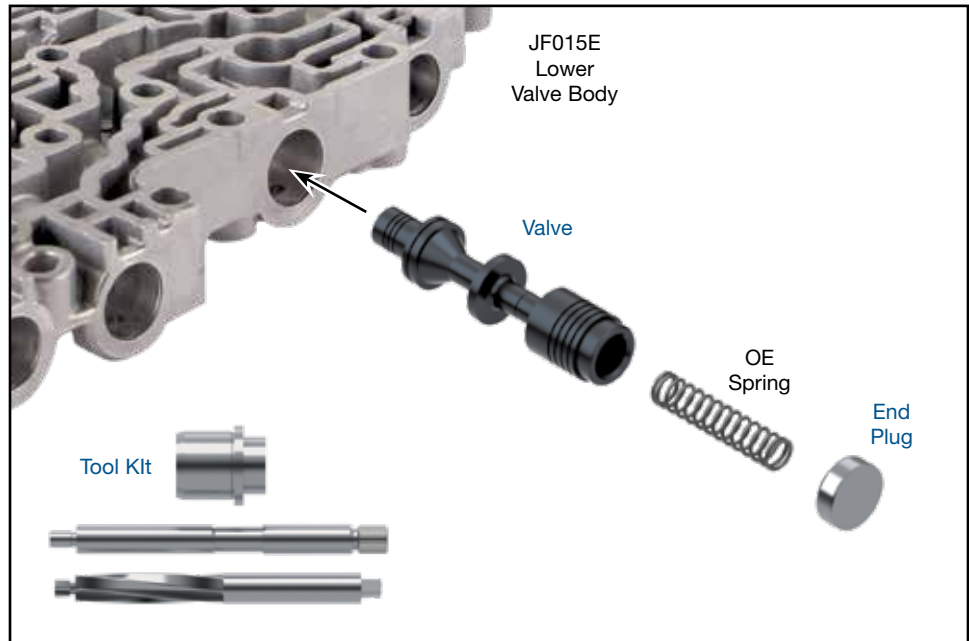

1. Disassembly

- Remove OE retainer pin and save for reuse.
- Remove OE end plug and discard.
- Remove and save OE spring for reuse.
- Remove OE valve and discard.

2. Bore Reaming

Ream secondary pulley/pressure regulator valve bore (for reaming instructions/reamer care, please visit www.sonnax.com). Sonnax reaming tool kit **F-33741F-TL** and **VB-FIX** are required for this operation.

3. Installation & Assembly

- Ensure all debris has been removed from valve bore and valve body.
- Install Sonnax valve into bore with spring pocket outboard.
- Reinstall OE spring into bore.
- Install Sonnax end plug.
- Reinstall OE retainer pin.

4. Final Testing

Vacuum testing at the port(s) indicated holds the recommended minimum 18 in.-Hg.

