

## Smart-Tech® Big Input Shaft Kit

### Part No.

# 22121B-08K

- Input Shaft 35 Spline
- Stator Support Assembly
- Direct Clutch Piston
- Steel Clutch Plate .068" Thick
- Seal Rings (3) 1 Extra
- Quad Ring Seals (4)

**NOTE:** Fits any 47RH/RE or 48RE converter fitted with a 35-spline turbine hub.

## Chrysler 47RE, 47RH, 48RE

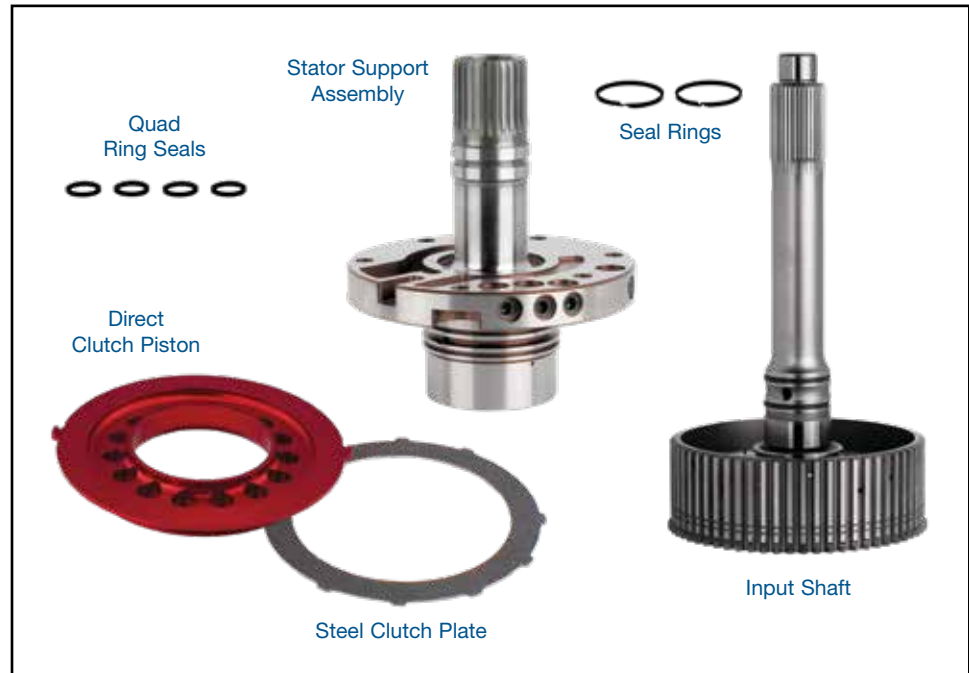

### Alternative Clutch Section:

The extended hub and thinner billet direct clutch piston increase overall clutch pack distance between piston and backing plate, allowing a variety of combinations of friction plates and steels. The chart below lists some that are available.

Friction Plates	.095" Thick
	.085" Thick
	.064" Thick
	.061" Thick
Steel Plates	.068" Thick
	.070" Thick
	.085" Thick
	.090" Thick

### 1. Assembly

- Install four Sonnax rubber quad ring seals onto Sonnax stator support assembly pump face. Secure in place with assembly lube (**Figure 1**).
- Assemble stator support assembly to oil pump body using published assembly procedures.
- Put small amount of thick assembly lube in two seal ring grooves before installing two Sonnax seal rings onto input shaft. (**Figure 2**).
- Carefully install input shaft with two installed seal rings into stator/pump assembly to size and verify fit of two sealing rings.
- Once the two Sonnax seal rings are sized and fit-checked, then install OE or after-market seal ring in third ring land (**Figure 2**).
- Assemble input shaft with rear clutch piston, retainer and related parts using published assembly procedures.

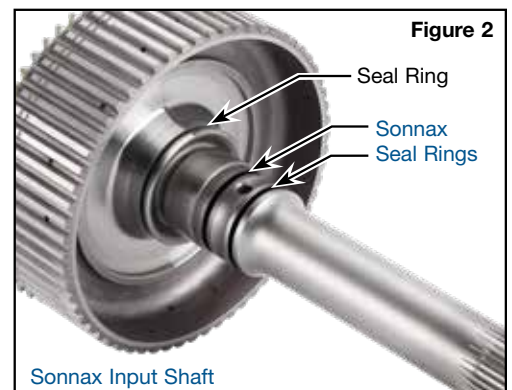
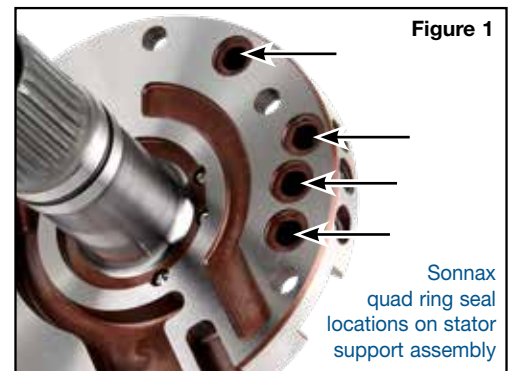

### 2. 48RE 5-Clutch Direct Drum

- Assemble Sonnax direct clutch piston using normal procedures.
- Place Sonnax steel clutch plate (.068" thick) against Sonnax direct clutch piston; orient plate's missing lugs over piston's anti-rotation tabs (**Figure 3**).
- Assemble clutch pack with one additional OE thickness friction for a total of six (.085" frictions) and five (.085") steel plates (**Figure 3**).
- Check clutch clearance. OE specification is .098–.161". With this kit, clearance will be near the low end of OE specification.

### 3. 47RE/RH 4-Clutch Direct Drum

- Assemble Sonnax direct clutch piston using normal procedures.
- Place Sonnax steel clutch plate (.068" thick) against Sonnax direct clutch piston; orient plate's missing lugs over piston's anti-rotation tabs (**Figure 4**).
- Assemble clutch pack with one additional OE thickness friction for a total of five (.085") frictions and four (.085") steel plates (**Figure 4**).
- Check clutch clearance. OE specification is .070–.129". With this kit, clearance will be near the low end of OE specification.

