

Oversized Lockup Control Valve Kit

Part No.
113741-22K

- Control Valve
- Spring
- Plunger Valve
- Plunger Sleeve

NOTE: Also fits Mitsubishi F1CJA.

Tool Kit

Part No.
F-113741-TL22

- Reamer
- Reamer Jig
- Guide Pin

NOTE: Sonnax "F-Tool" kits designed to service a specific bore require the VB-FIX, a self-aligning valve body reaming fixture. More information and instructions can be found online at www.sonnax.com.



Jatco/Nissan JF010E (REOF09A/REOF09B), JF011E (REOF10A)

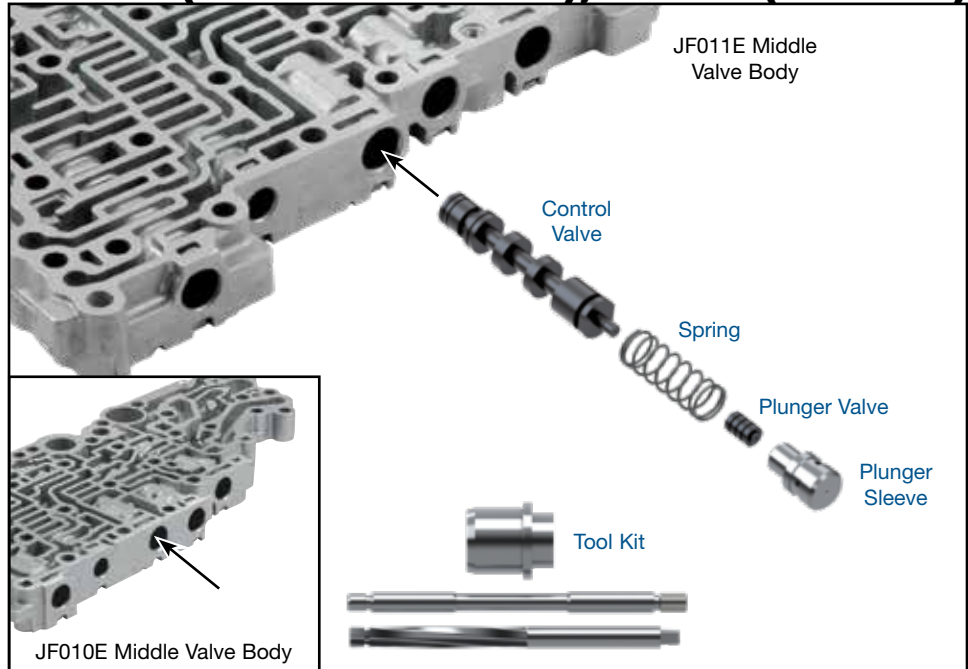

1. Disassembly

- Remove OE retainer pin and save for reuse.
- Remove OE lockup control valve train from bore and discard.

2. Bore Reaming

Ream lockup control valve bore (for reaming instructions/care, please visit www.sonnax.com). Sonnax reaming tool kit **F-113741-TL22** and **VB-FIX** are required for this operation.

3. Installation & Assembly

- Be certain all debris has been removed from the valve bore and valve body.
- Install Sonnax control valve into reamed bore. Thin valve spool with flats must be outboard.
- Install Sonnax spring included with kit.
- Install Sonnax plunger valve and sleeve assembly with snout inside spring.
- Reinstall OE pin to retain sleeve.

4. Final Testing

Vacuum testing at the port(s) indicated holds the recommended minimum 16 and 18 in-Hg.

