

Oversized Actuator Feed Limit Valve Kit

Part No.
124740-48K

- Valve
- Spring



Tool Kit

Part No.
F-124740-TL48

- Reamer
- Reamer Jig
- Guide Pin



NOTE: Sonnax “F-Tool” kits designed to service a specific bore require the VB-FIX, a self-aligning valve body reaming fixture. More information and instructions can be found online at www.sonnax.com.

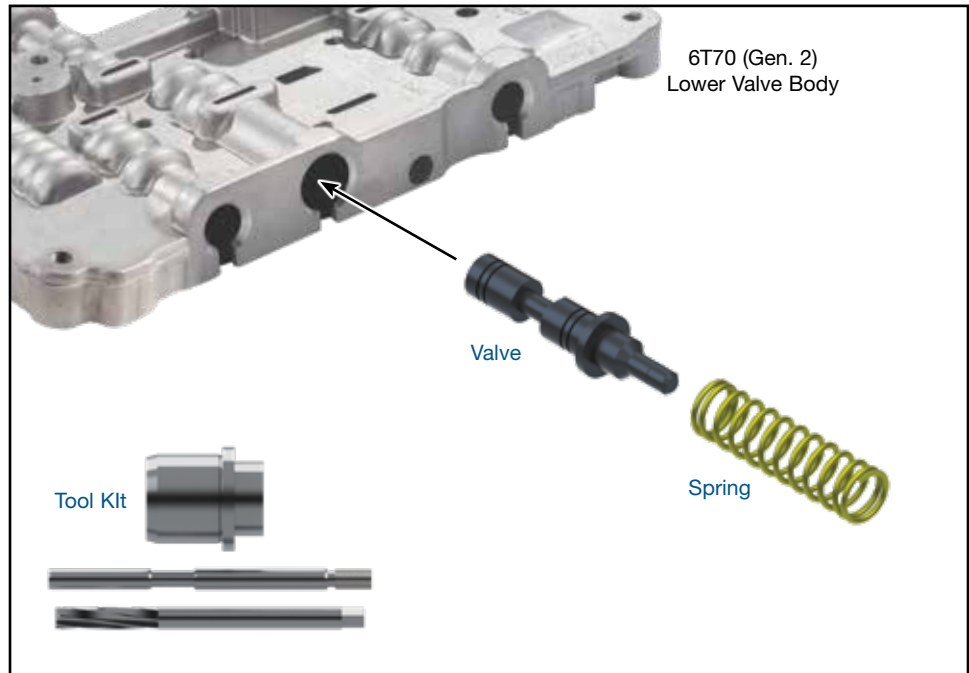

GM Gen. 2 6T70/75/80

1. Disassembly

- Remove OE retainer, save for reuse.
- Remove OE valve and spring.



NOTE: Valve kit **124740-48K** is ONLY for Gen. 2 applications. Tool kit **F-124740-TL48** will work in both Gen. 1 and Gen. 2 GM 6T70/75/80 applications, but Sonnax valve **124740-01** and tool kit **F-104740-TL12** CANNOT be used in Gen. 2 applications. Use of the wrong valve and tool kit can cause spring coil bind and issues with proper valve regulation (**Figure 1**).

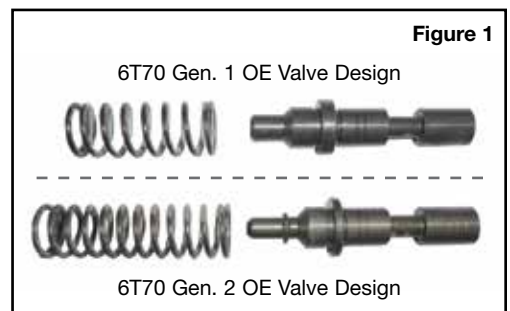

2. Bore Reaming

Ream actuator feed limit bore (for reaming instructions/care, please visit www.sonnax.com). Sonnax reaming tool kit **F-124740-TL48** and **VB-FIX** are required for this operation.

3. Installation & Assembly

- Be certain all debris has been removed from the valve bore and valve body.
- Install Sonnax valve and spring.
- Reinstall OE retainer.

4. Final Testing

Vacuum testing at the port(s) indicated holds the recommended minimum 18 in-Hg.

