

GM 6T40 (Gen. 1), 6T40 (Gen. 2), 6T45 (Gen. 1), 6T45 (Gen. 2), 6T50 (Gen. 1), 6T50 (Gen. 2)

3-5-R Drum Saver Kit

Part No.

144555K

- Cupped Steel Plate
- Waved Plate

Also Available:

GM Gen. 1 & 2 6T70, 6T75

3-5-R Drum Saver Kit

124555K

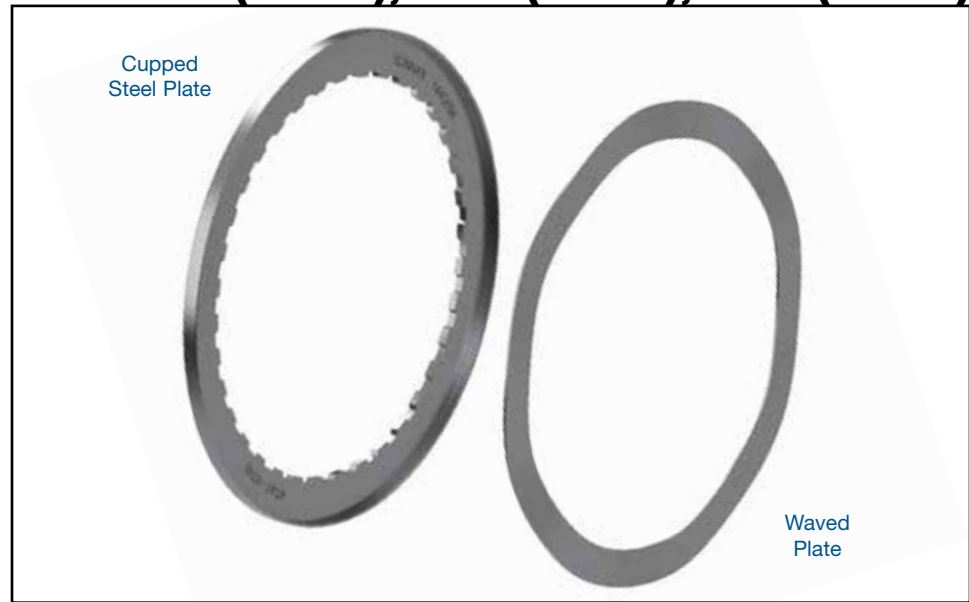

1. Disassembly

- Remove OE 3-5-R clutch pack.
- Locate, remove and discard all pieces of broken OE waved plate.
- Discard OE steel plate located next to waved plate.

2. Installation & Assembly

- Verify updated piston is installed by measuring piston height. Correct updated piston is about 1.132" tall. If piston height measures about 1.105" tall, this indicates an early-style piston that must be upgraded. See note below step 3 for additional details.
- Install Sonnax waved plate on top of piston.
- Install Sonnax cupped steel plate on top of waved plate, lip facing downward (**Figure 1**).
- Continue assembling clutch pack as shown (**Figure 1**).

3. Verify Correct Clearance

After snap ring installation, verify clutch pack clearance is within specification (.020-.060") using a dial indicator.



NOTE: If there is too much clearance, either the piston has been distorted or an early-style piston is installed. Early-style pistons should never be used in any 6T40/45/50 build.

In the event you have too much clearance after installation of Sonnax kit, measure piston height; the early style piston height is about 1.105" and should NOT be used.

Updated OE piston 24259061 or aftermarket equivalent must be used. This piston height is about 1.132".

While the OEM does not sell early-style pistons anymore, be aware there are aftermarket suppliers still selling them.

