

Vacuum Test Plate Kit

Part No.
37000-VTP



- Main Plate
- Shift Plate
- Seals (2)
- Push Pins (10) 2 Extra
- Alignment Pins (2)
- Bolts (8) 1 Extra
- Washers (10) 5 Extra
- Test Plugs (5)
- O-Rings (12) 6 Extra
- Retainer Clips (2)
- Wing Nuts (3)

Vacuum Test Stand Kit

Part No.
VACTEST-01K

- Vacuum Test Stand
- Test Plate
- Vacuum Plate Sealing Pad
- Vacuum Test Foam Pad
- Push-to-Connect Fitting
- Assorted Testing Tips (6)
- Testing Tip Adapter Tube
- Flexible Tubing
- Flared Tubing with Flared Nut

Instructions

1. Assembly

- a. Ensure vacuum test plate and seal are both clean and free of debris.
- b. Install two alignment pins into shift valve body plate at indicated threaded holes. Thread into non-engraved side of plate (**Figure 1**). The main valve body plate has four holes that align with the OE dowel pins in the casting.
- c. Place seal onto non-engraved side of plate, aligning orifice holes. Remove any entrapped air between plate and seal by peeling seal up at plate edge. Gradually place seal back on plate from center toward edge.
- d. Push plastic push pins into seal and plate from seal side, just far enough for head to lightly contact seal.

2. Testing

- a. Place assembled vacuum test plate over casting, using engraved casting outline as guide. Alignment pins should enter casting bolt holes.
- b. Using Sonnax vacuum test stand kit **VACTEST-01K** (sold separately, **Figure 2**) and small vacuum tip, vacuum test at numbered orifices on plate. These numbers correspond to the bore numbers called out in the exploded view of the valve body on page 6. The chart on page 12 provides descriptions of individual circuit checked and space to document actual vacuum readings and minimum vacuum standards.

NOTE: Vacuum Test Data Sheet on page 11 can be used to establish minimum vacuum standards at individual bore locations.

- c. These castings are prone to significant warpage and have long worm tracks, so additional palm force downward on plate may be needed. Included bolts, wingnuts and washers are included to clamp plate to casting and are highly recommended.
- d. Various plugs and O-rings are included and required for proper testing. Details for assembly and usage can be found on pages 4 and 5.

3. Cleaning

Seal and plate can be cleaned as needed with mild soap and water to remove debris.

4. What should my vacuum test results be?

While a properly calibrated and maintained test stand will give consistent vacuum reading results for a specific circuit and amount of wear, evaluating these results requires establishing your own pass/fail criteria. Variables which influence vacuum readings are the number of spools tested in a captive circuit, spool diameter size and contact length of the spool within the bore.

Pass/Fail standards are specific to your setup and process, but they also must be based on your experience, quality sensitivity, warranty concerns and cost/pricing structure. Sonnax recommends that you keep a record of vacuum results for each valve body at each tested circuit/port location. This lets you compare results over time to help determine for your shop what an acceptable vacuum reading is for each circuit/port location.

A chart specific to this application is provided in this booklet indicating valve and circuit checked at each orifice location. Room is provided to record results and compare to your minimum vacuum standard. A generic vacuum test data sheet also is provided that can be used to evaluate multiple cores to establish your minimum vacuum standard. These documents can be printed or downloaded and stored on your computer.

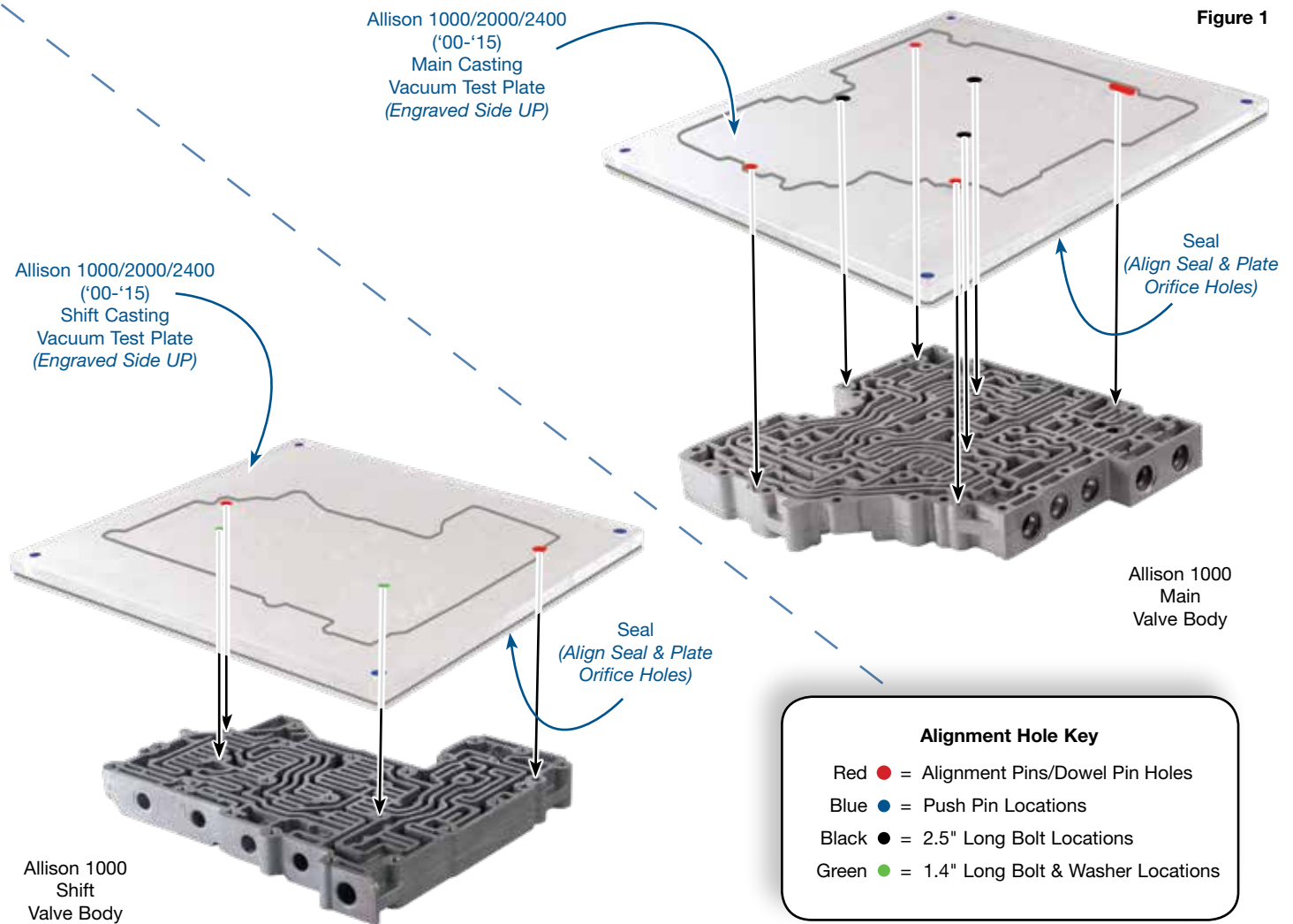

Vacuum Test Stand Kit

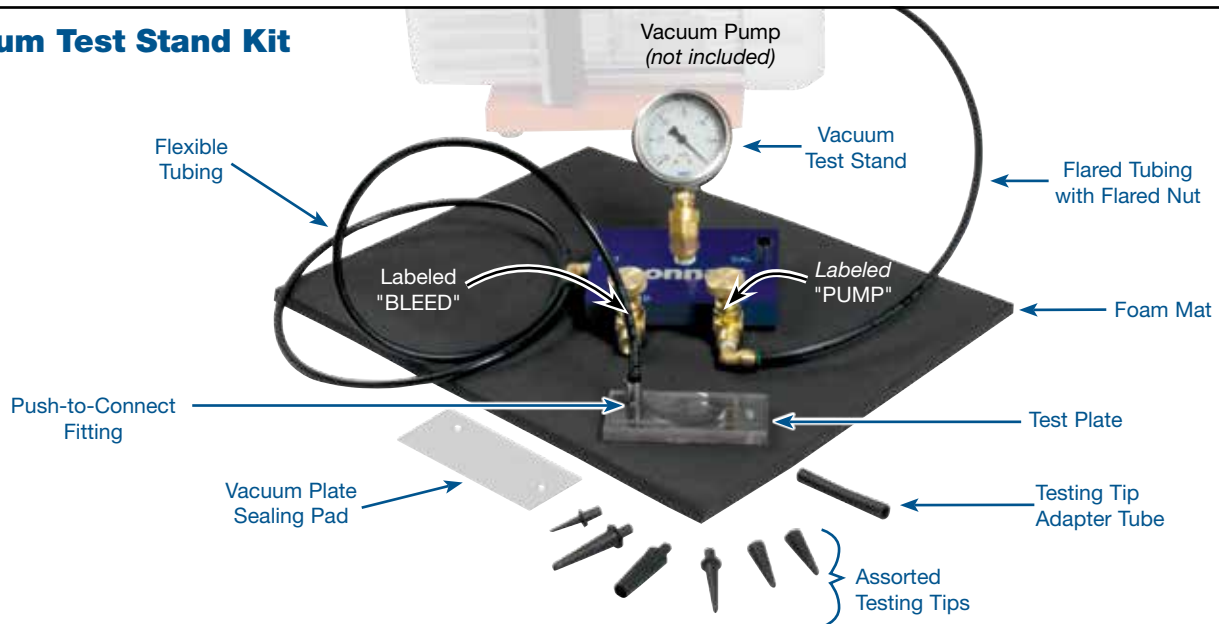

Critical Wear Areas & Vacuum Test Locations



NOTE: OE valves are shown in rest position and should be tested in rest position unless otherwise indicated. Test locations are pointed to with an arrow. Springs are not shown for visual clarity. Low vacuum reading indicates wear and Sonnax parts are noted for replacement.

Main Valve Body • '06-'09 Years Only



NOTE: Castings, valves and worm tracks vary between versions as do vacuum test locations.



For specific vacuum test information, refer to individual part instructions included in kits and available at www.sonnax.com.

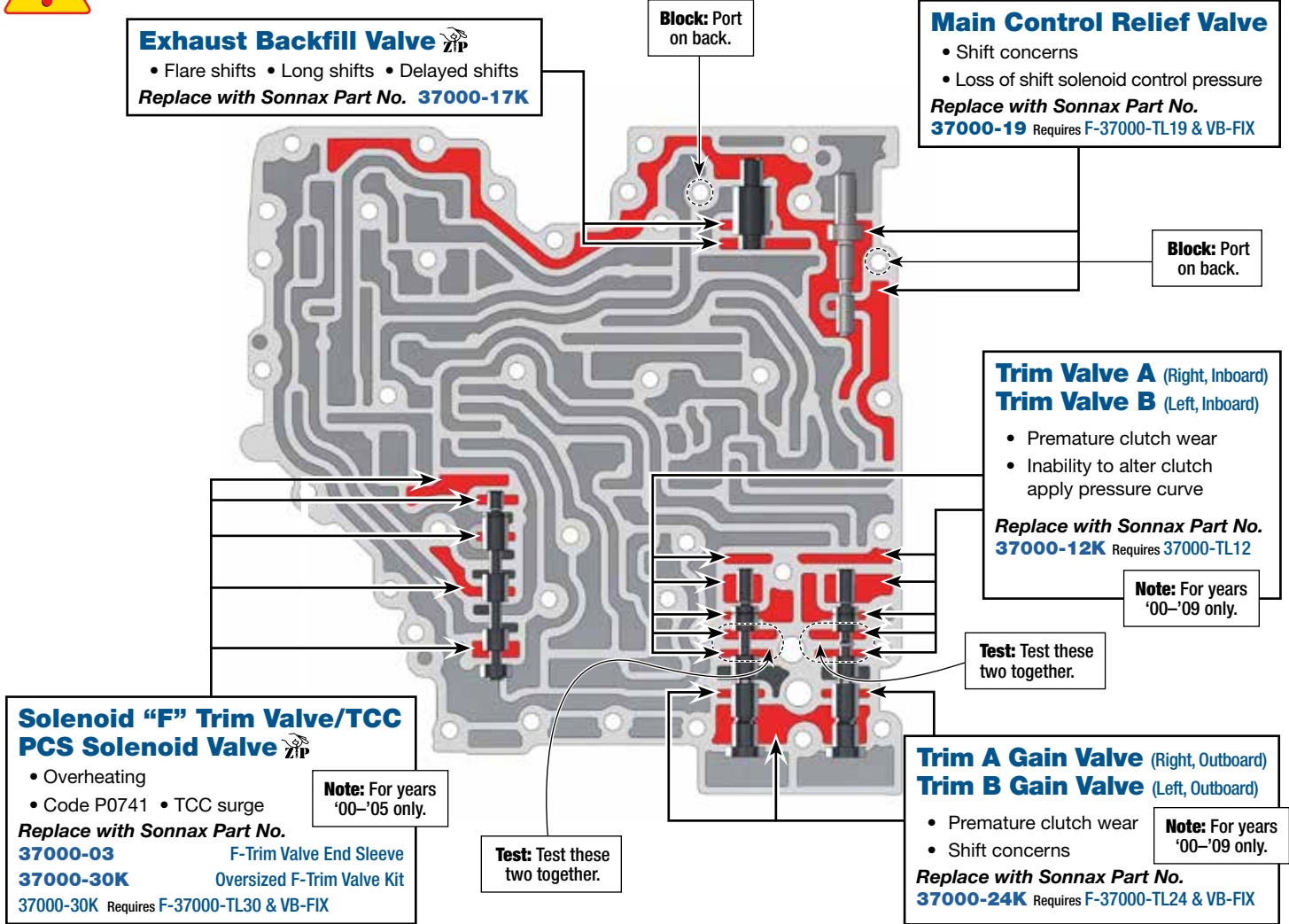

Test Plugs • Required for proper testing of different circuits

Reference legends and instructions for requirements and locations to be used on pages 7-10 and page 12.



Fixed plug for Trim and Gain A Valve location (Bore 103).
Used as required. Install green O-Ring B17889 in medium groove.
Hold in casting with supplied retaining clip.



Fixed plug for Trim and Gain B Valve location (Bore 104).
Used as required. Install O-Ring B17890 in medium groove.
Hold in casting with supplied retaining clip.

Critical Wear Areas & Vacuum Test Locations



Drop-In Zip Valve™
Parts Available

NOTE: OE valves are shown in rest position and should be tested in rest position unless otherwise indicated. Test locations are pointed to with an arrow. Springs are not shown for visual clarity. Low vacuum reading indicates wear and Sonnax parts are noted for replacement.

Shaft Valve Body • '06-'09 Years Only



NOTE: Castings, valves and worm tracks vary between versions as do vacuum test locations.

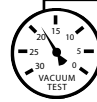

For specific vacuum test information, refer to individual part instructions included in kits and available at www.sonnax.com.

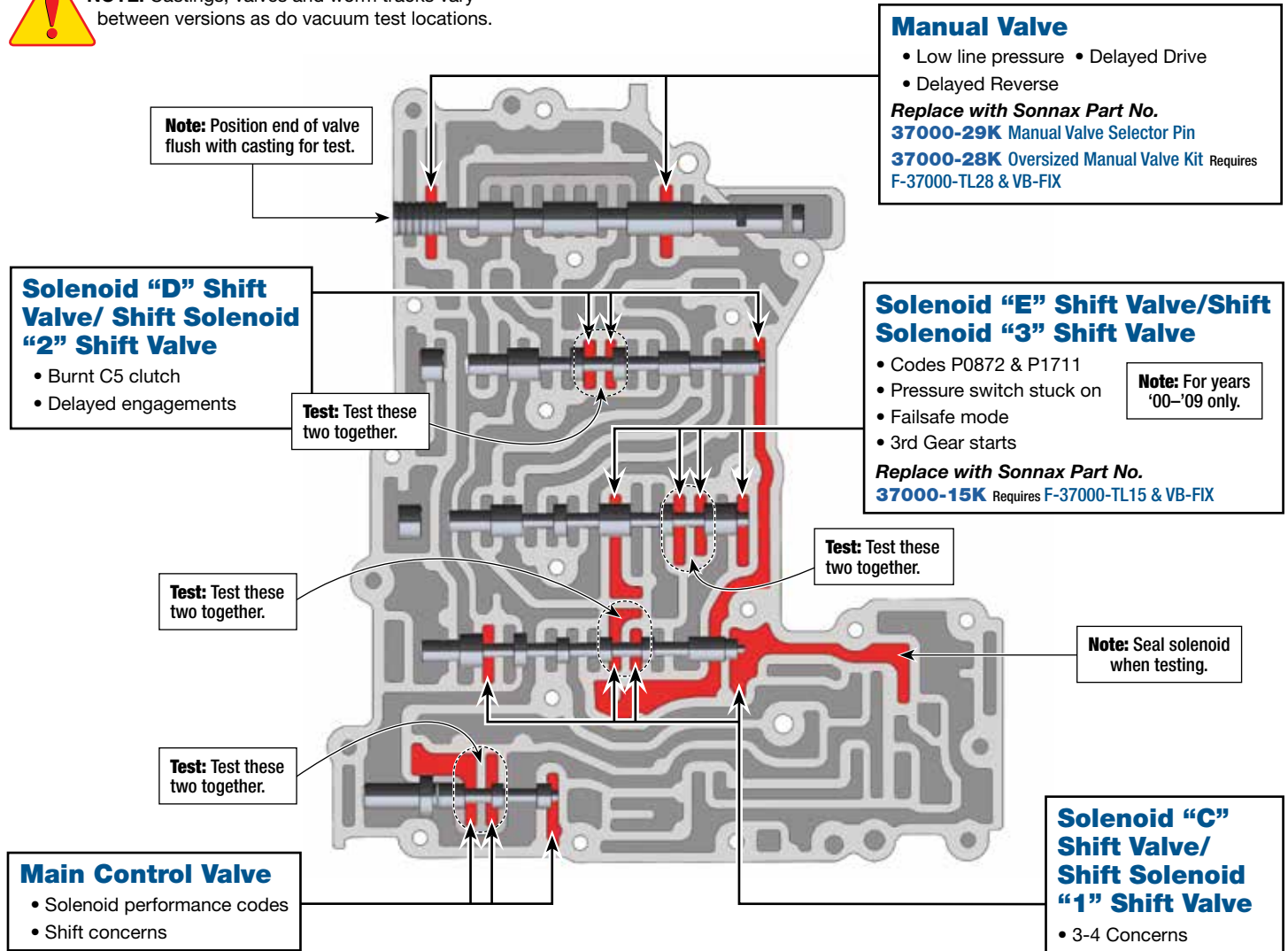

- Plug 202**

Fixed plug for "C" Shift Valve location (Bore 202).
Used as required. Install O-ring OR-013 in inboard groove and O-ring OR-015 in middle groove.
Place small 10-32 nut in inboard casting to prevent over-stroke of plug into bore.
- Plug 105**

Fixed plug for "F" Trim valve location (Bore 105).
Used as required. Install O-ring (OR-10.5x2) in middle groove.
NOTE: For '06-'09 valve bodies, do not use plug 105 but instead use the OE lockup solenoid to ensure valve is in the correct position when testing.
- Plug A-B**

Movable plug for Trim A & B Gain Valve locations (Bore 103 & 104). Used as required.
Thread long socket-head screw into outboard face to use as handle for moving plug inboard and outboard while testing.

OE Exploded View

NOTE: Depending upon vehicle application, the OE springs shown may not be present.

Main Valve Body

Shift Valve Body

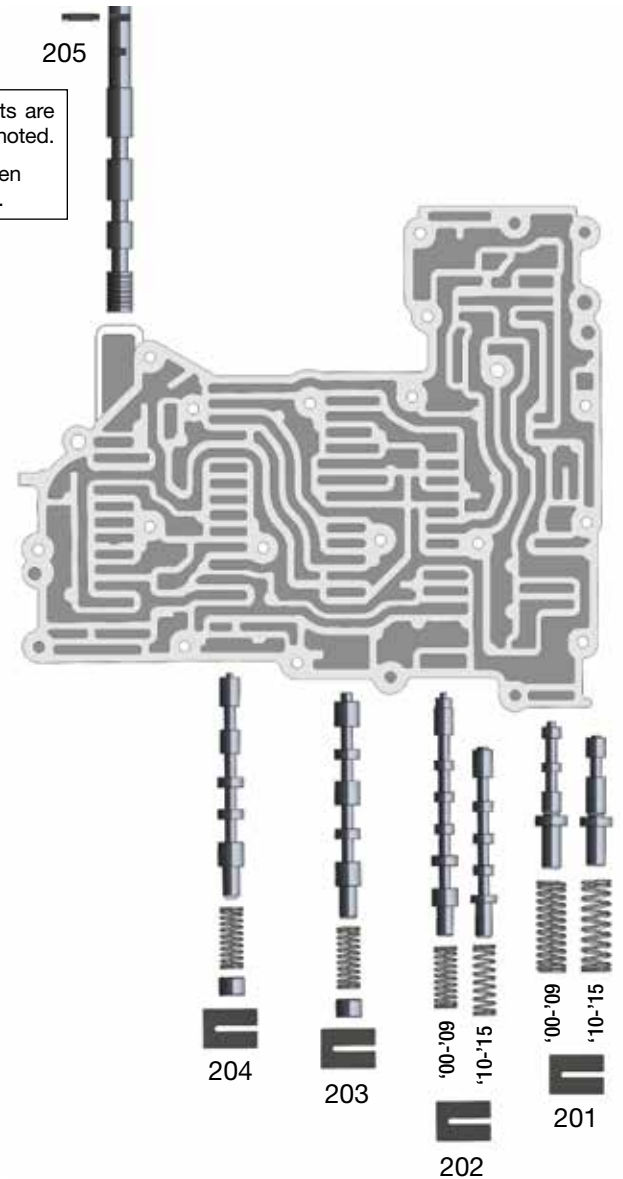
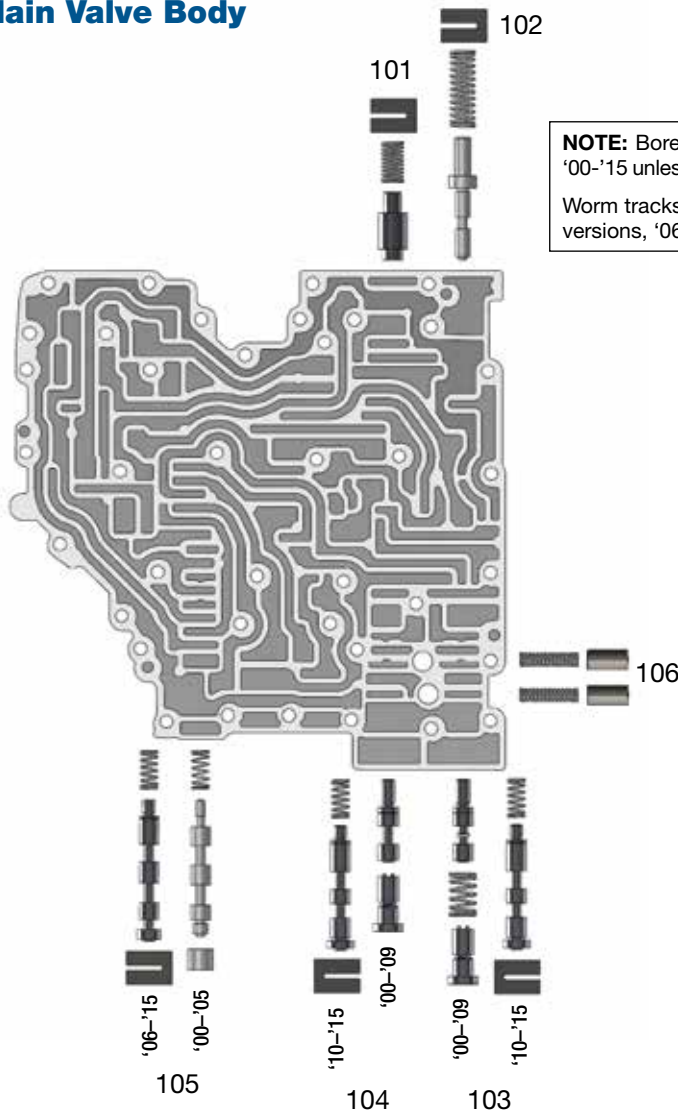

NOTE: Bore Components are '00-'15 unless otherwise noted.
Worm tracks vary between versions, '06-'09 Shown.

Main Valve Body Descriptions	
I.D. No.	Description
101	Exhaust Backfill Valve
102	Main Control Relief Valve
103	Trim A Valve (Inner '00-'09) Trim A Gain Valve (Outer '00-'09) Pressure Control Valve 1 ('10-'15)
104	Trim B Valve (Inner '00-'09) Trim B Gain Valve (Outer '00-'09) Pressure Control Valve 2 ('10-'15)
105	Solenoid "F" Trim Valve ('00-'05) TCC PCS Solenoid Valve ('06-'15)
106	Accumulators

Shift Valve Body Descriptions	
I.D. No.	Description
201	Main Control Valve
202	Solenoid "C" Shift Valve ('00-'09) Shift Solenoid "1" Shift Valve ('10-'15)
203	Solenoid "E" Shift Valve ('00-'09) Shift Solenoid "3" Shift Valve ('10-'15)
204	Solenoid "D" Shift Valve ('00-'09) Shift Solenoid "2" Shift Valve ('10-'15)
205	Manual Valve

'00-'03 Years

NOTE: Test with main and shift castings on foam pad to seal circuits on back. Adjust pad on main casting so edge butts against dowel pin on back side. Recommend positioning casting so side with solenoids/test plugs hangs off bench slightly. Castings are prone to warpage, so bolts are recommended. Additional palm force downward on plate may be needed. Vacuum testing should be performed at all test ports that are colored green. Note the need for special test plugs at some bore locations.

Main Casting

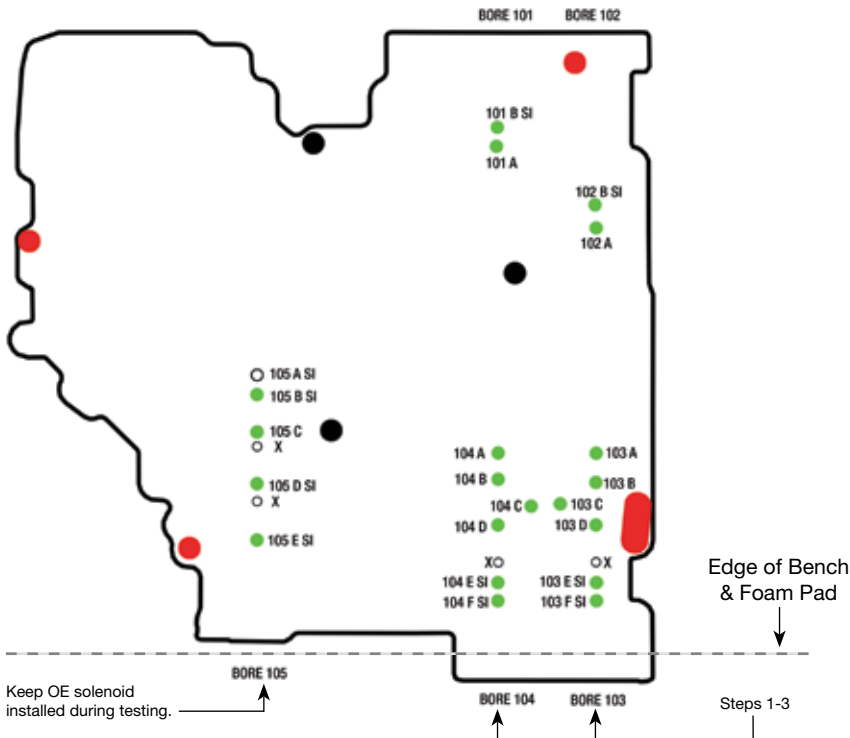

1. Remove solenoids and install fixed test plugs 103 and 104 into bores 103 and 104 during vacuum testing. Test ports 103 and 104 A-F. When testing 103F block port 104F and vice-versa.
2. Remove fixed test plug 103 from bore 103. Remove outboard OE gain valve. Install moveable test plug A-B with screw outboard.
 - a. With plug A-B outboard test ports 103E & F. When testing 103F, block port with 104F.
 - b. Push plug inboard and test ports 103A, B, E & F. When testing 103F, block port 104F.
3. Remove movable test plug A-B from bore 103 and return OE gain valve. Install fixed plug 103 in bore 103. Remove fixed plug 104 from bore 104 and duplicate test 2 above for bore 104 using moveable test plug.

Shift Casting

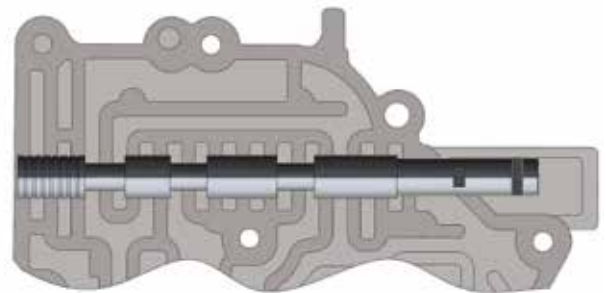
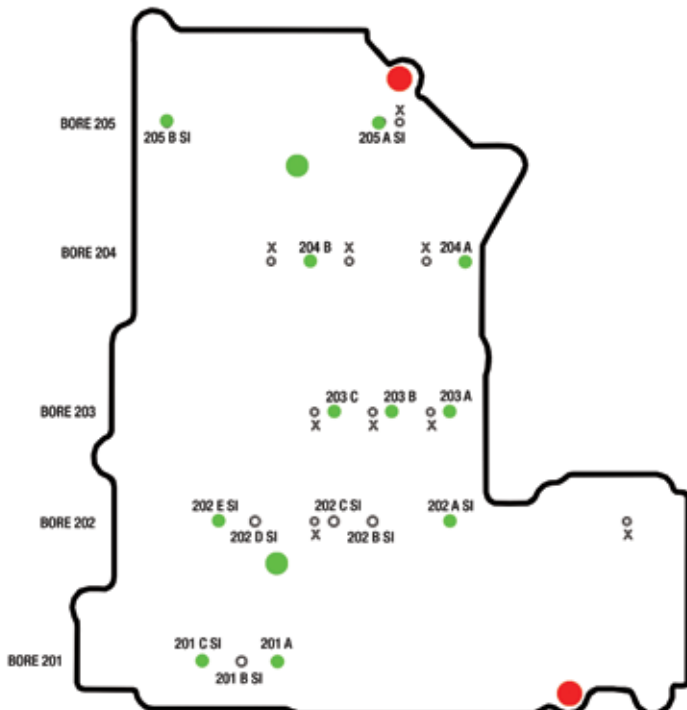

Position manual valve as indicated for testing ports 205A and 205B.

Place nut in inboard port to prevent over-stroke of the test plug. Slide O-ringed test plug 202 into bore for testing bore 202 ports.

'04-'05 Years

NOTE: Test with main and shift castings on foam pad to seal circuits on back. Adjust pad on main casting so edge butts against dowel pin on back side. Recommend positioning casting so side with solenoids/test plugs hangs off bench slightly. Castings are prone to warpage, so bolts are recommended. Additional palm force downward on plate may be needed. Vacuum testing should be performed at all test ports that are colored green. Note the need for special test plugs at some bore locations.

Main Casting

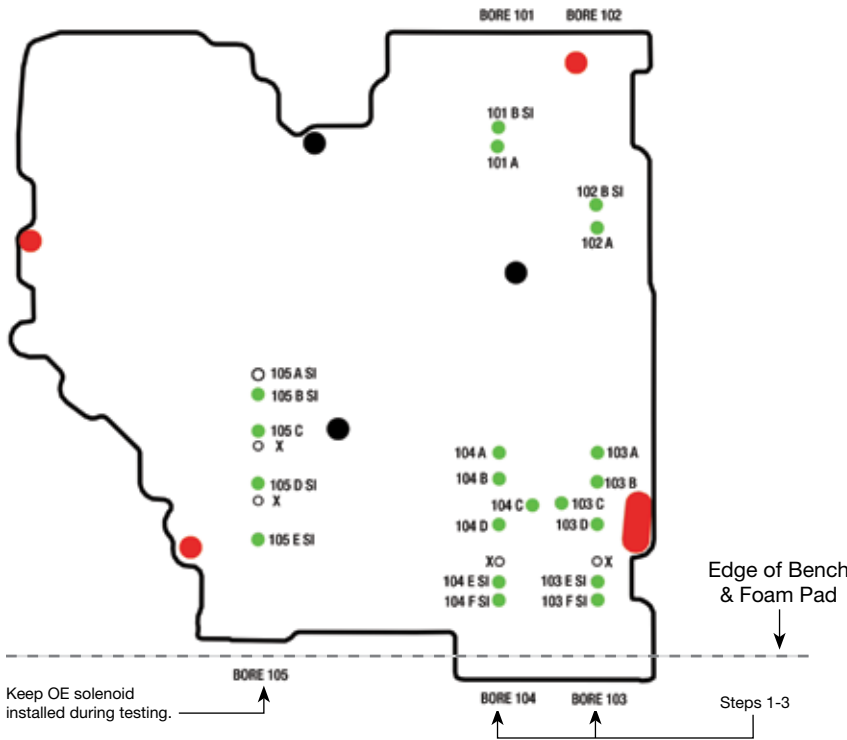

1. Remove solenoids and install fixed test plugs 103 and 104 into bores 103 and 104 during vacuum testing. Test ports 103 and 104 A-F. When testing 103F block port 104F and vice-versa.
2. Remove fixed test plug 103 from bore 103. Remove outboard OE gain valve. Install moveable test plug A-B with screw outboard.
 - a. With plug A-B outboard test ports 103E & F. When testing 103F, block port with 104F.
 - b. Push plug inboard and test ports 103A, B, E & F. When testing 103F, block port 104F.
3. Remove movable test plug A-B from bore 103 and return OE gain valve. Install fixed plug 103 in bore 103. Remove fixed plug 104 from bore 104 and duplicate test 2 above for bore 104 using moveable test plug.

Shift Casting

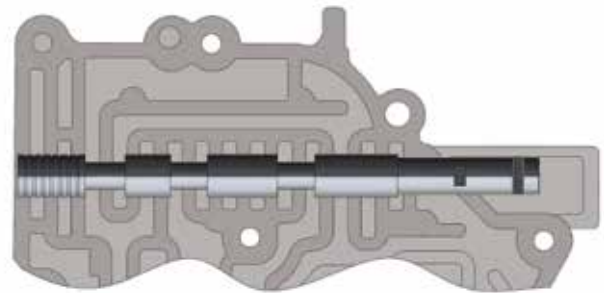
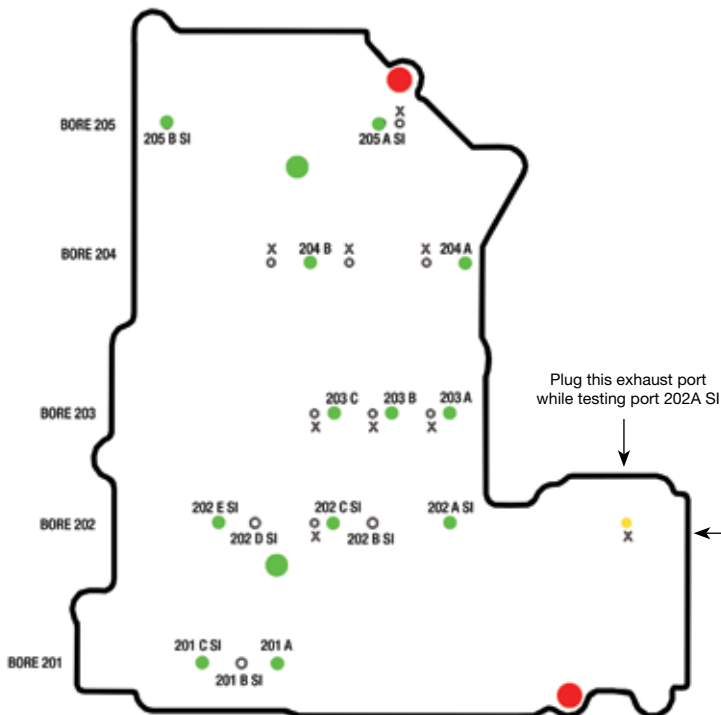

Position manual valve as indicated for testing ports 205A and 205B.

Place nut in inboard port to prevent over-stroke of the test plug. Slide O-ringed test plug 202 into bore for testing bore 202 ports.

'06-'09 Years

NOTE: Test with main and shift castings on foam pad to seal circuits on back. Adjust pad on main casting so edge butts against dowel pin on back side. Recommend positioning casting so side with solenoids/test plugs hangs off bench slightly. Castings are prone to warpage, so bolts are recommended. Additional palm force downward on plate may be needed. Vacuum testing should be performed at all test ports that are colored green. Note the need for special test plugs at some bore locations.

Main Casting

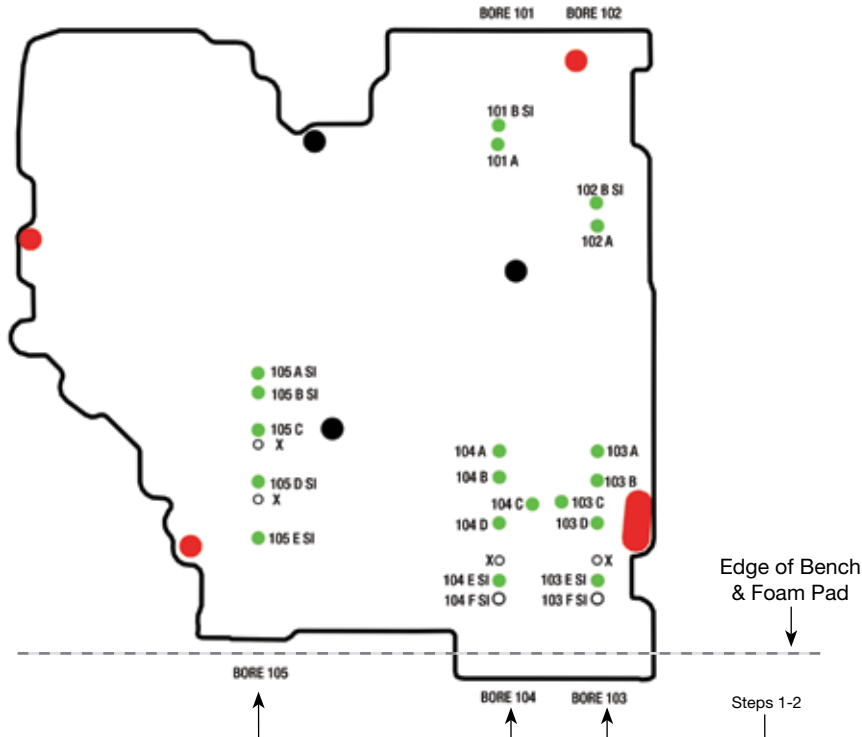

Remove solenoids and install fixed test plugs 103 and 104 into bores 103 and 104 during vacuum testing. Test ports 103 and 104 A-E.

Shift Casting

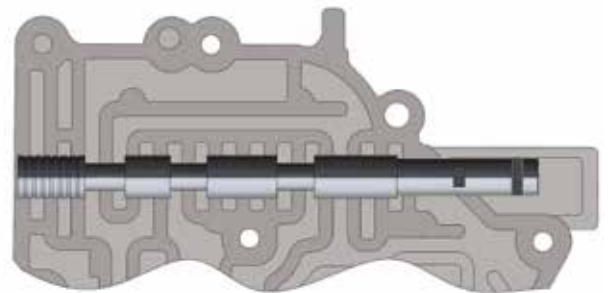
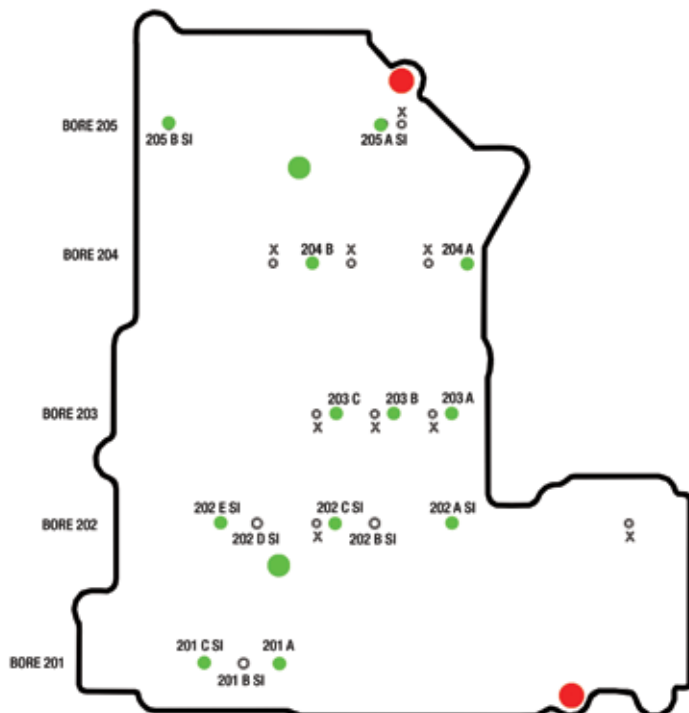

Position manual valve as indicated for testing ports 205A and 205B.

Place nut in inboard port to prevent over-stroke of the test plug. Slide O-ringed test plug 202 into bore for testing bore 202 ports.

'10-'15 Years

NOTE: Test with main and shift castings on foam pad to seal circuits on back. Adjust pad on main casting so edge butts against dowel pin on back side. Recommend positioning casting so side with solenoids/test plugs hangs off bench slightly. Castings are prone to warpage, so bolts are recommended. Additional palm force downward on plate may be needed. Vacuum testing should be performed at all test ports that are colored green. Note the need for special test plugs at some bore locations.

Main Casting

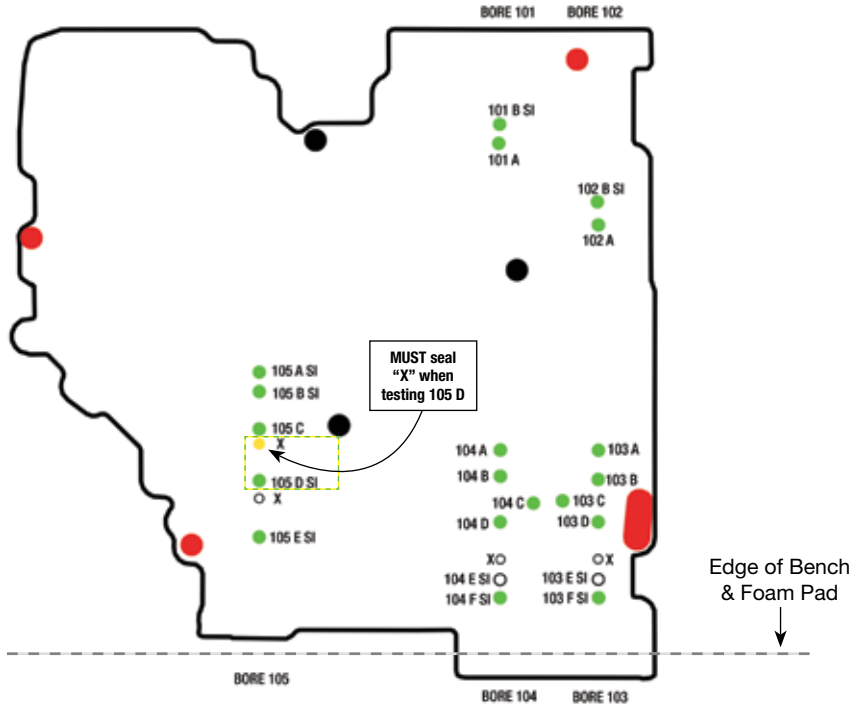

Test with OE solenoids installed in bores 103, 104 and 105. Test with OE stamped steel brackets removed.

Shift Casting

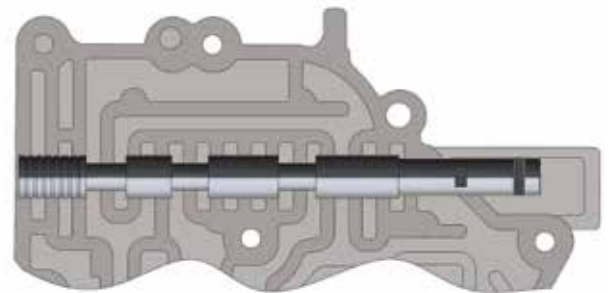

Position manual valve as indicated for testing ports 205A and 205B.

Test with OE solenoid installed.

Orifice Legend

Unit Stock or Tag No.

	Orifice Location	Valve/Circuit Checked	Sonnax Part Number	Special Instructions	Actual Vacuum Reading	Minimum Vacuum Standard
Main Valve Body	101A	Exhaust Backfill Valve	37000-17K			
	101B	Exhaust Backfill Valve				
	102A	Main Control Relief Valve	37000-19			
	102B	Main Control Relief Valve				
	103A	Trim "A" Valve	37000-12K	Test with plug if required		
	103B	Trim "A" Valve				
	103C	Trim "A" Valve				
	103D	Trim "A" Valve				
	103E	Trim "A" Gain Valve	37000-24K	Test with plug if required		
	103F	Trim "A" Gain Valve				
	104A	Trim "B" Valve	37000-12K	Test with plug if required		
	104B	Trim "B" Valve				
	104C	Trim "B" Valve				
	104D	Trim "B" Valve				
	104E	Trim "B" Gain Valve	37000-24K	Test with plug if required		
	104F	Trim "B" Gain Valve				
	105A	Solenoid "F" Trim Valve	37000-03 37000-30K	For '06-'09 valve bodies use OE lockup solenoid during testing to ensure proper alignment		
	105B	Solenoid "F" Trim Valve				
105C	Solenoid "F" Trim Valve					
105D	Solenoid "F" Trim Valve					
105E	Solenoid "F" Trim Valve					
Shift Valve Body	201A	Main Control Valve				
	201B	Main Control Valve				
	201C	Main Control Valve				
	202A	Solenoid "C" Shift Valve		Test with plug if required		
	202B	Solenoid "C" Shift Valve				
	202C	Solenoid "C" Shift Valve				
	202D	Solenoid "C" Shift Valve				
	202E	Solenoid "C" Shift Valve				
	203A	Solenoid "E" Shift Valve	37000-15K			
	203B	Solenoid "E" Shift Valve				
	203C	Solenoid "E" Shift Valve				
	204A	Solenoid "D" Shift Valve				
	204B	Solenoid "D" Shift Valve				
205A	Manual Valve	37000-28K 37000-29K	Position valve as illustrated			
205B	Manual Valve					

NOTE: The TCC control valve, converter feed limit valve, pressure regulator valve, and boost assembly reside in the pump body. These vacuum test plates do not check for wear in the pump body. Please reference the vacuum test locations on page 4 of this guide, and test using the small test plate and sealing pad included in the **VACTEST-01K**.