

Oversized Primary Pulley Reducing Valve Kit



Part No.

33510N-03K

- Valve
- End Plug

Tool Kit



Part No.

F-33510N-TL3

- Reamer
- Reamer Jig
- Guide Pin

NOTE: Sonnax “F-Tool” kits designed to service a specific bore require the VB-FIX, a self-aligning valve body reaming fixture. More information and instructions can be found online at www.sonnax.com.

Jatco/Nissan JF016E (RE0F10D)

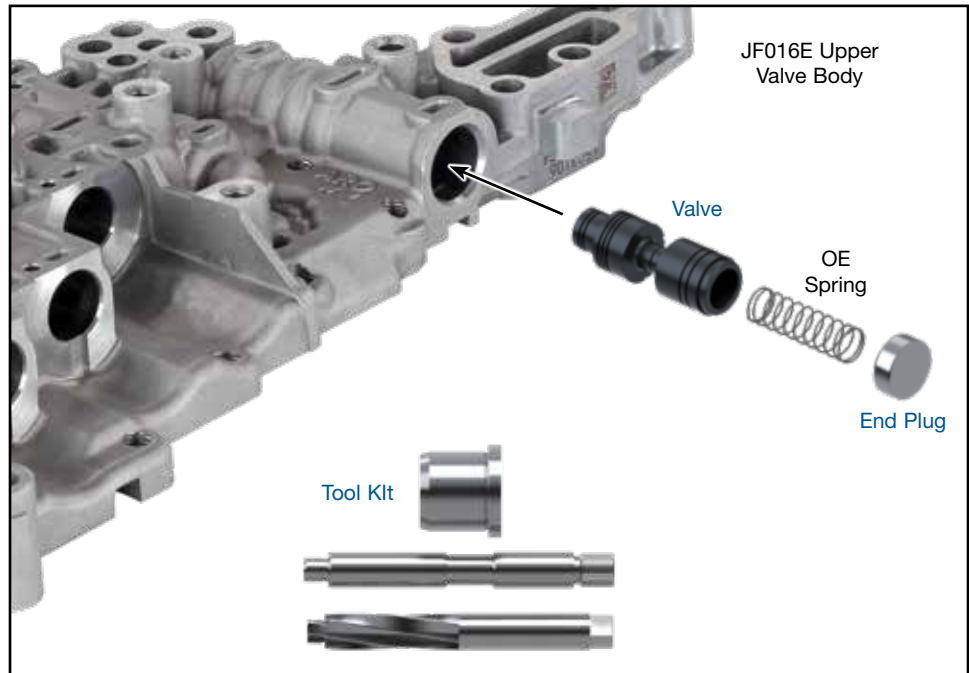

1. Disassembly

- Remove OE primary pulley reducing valve train lineup.
- Discard OE valve and end plug.
- Save OE spring and retainer for reuse.

2. Bore Reaming

Ream primary reducing valve bore (for reaming instructions/reamer care, please visit www.sonnax.com). Sonnax reaming tool kit **F-33510N-TL3** and **VB-FIX** are required for this operation.

3. Installation & Assembly

- Be certain all debris has been removed from the valve bore and valve body.
- Install Sonnax valve into reamed bore, spring pocket outboard.
- Reinstall OE spring into Sonnax valve spring pocket.
- Install Sonnax end plug.
- Reinstall OE retainer pin.

4. Final Testing

Vacuum testing at the port(s) indicated holds the recommended minimum 16 and 18 in-Hg.

