

Solenoid Modulator Valve Kit

Part No.

47740-42K

- Valve
- Sleeve
- Selective Shims (2)
- Spring
- End Plug
- Drill Bit .062"
- Plugs (2) 1 Extra*
- Rivets (2) 1 Extra*

Patent No. 8,919,381

*NOTE: For separator plate, not shown.

Toyota/Lexus U760E, U760F

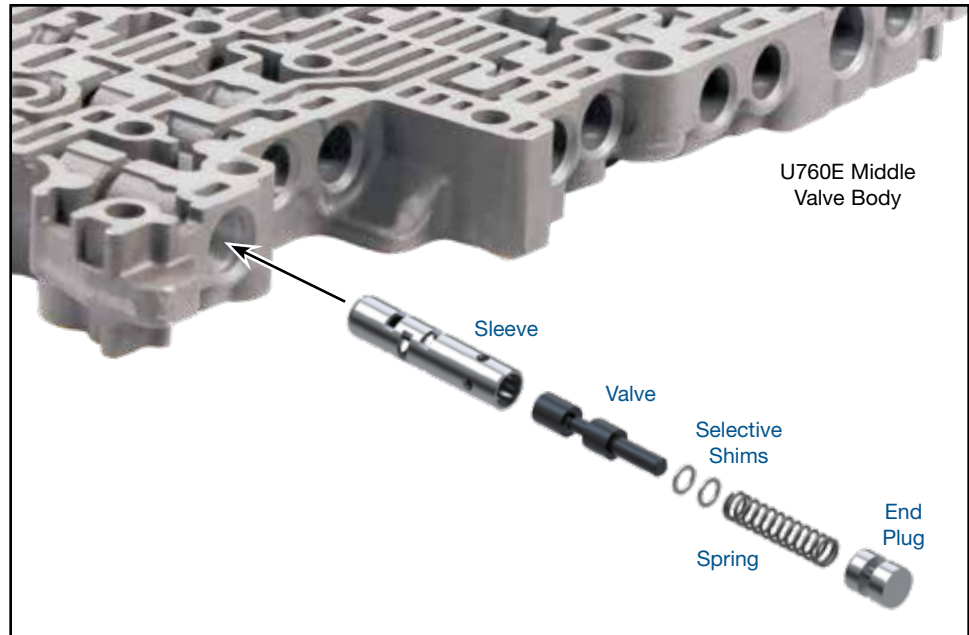

CAUTION: If OE end plug is adjustable, note which setting the end plug is set to. This will be needed during installation of Sonnax kit.

1. Disassembly

- a. Note and record adjustable end plug setting position, if applicable, then remove OE lineup.
- b. Save OE retainer for reuse.
- c. Discard OE valve, spring and end plug.

2. Drill & Plug Separator Plate Balance Orifice at Solenoid Modulator Valve

- a. Using included drill bit, drill solenoid modulator balance orifice to .062" (**Figure 1**).
- b. If using straight plug, insert into orifice and peen on both sides of plate.
- c. If using optional small rivet, insert into orifice and using wire cutters, snip the stem end of the rivet if/as necessary to provide for a small head once peened in place. Peen the rivet in place on head side of plate also.
- d. After peening on both sides of the plate, ensure plate will still fit flush on mating surfaces.

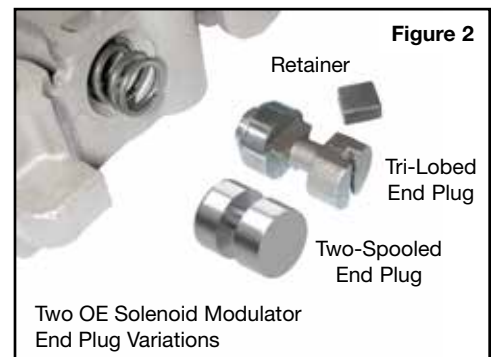
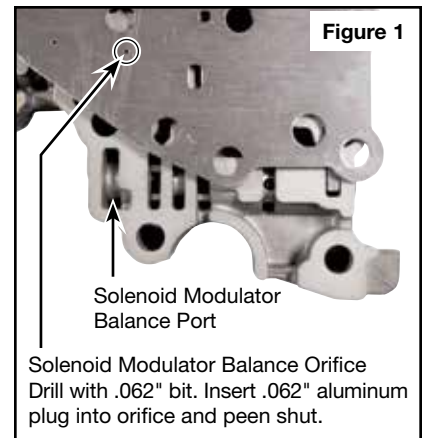

3. Limit Pressure Adjustment

- a. If the OE lineup used a standard two-spooled end plug (similar to that shown in **Figure 4**), proceed to **Step 4** and do not use any Sonnax selective shims (**Figure 2**).
- b. Determine if selective shims are required:
 - If OE retainer was installed at the most narrow location (**Figure 3, A**) of adjustable plug, no Sonnax selective shims are required.
 - If OE retainer was installed at the middle spool location (**Figure 3, B**) of adjustable plug, one Sonnax selective shims is required.
 - If OE retainer was installed at the widest spool location (**Figure 3, C**) of adjustable plug, two Sonnax selective shims are required.

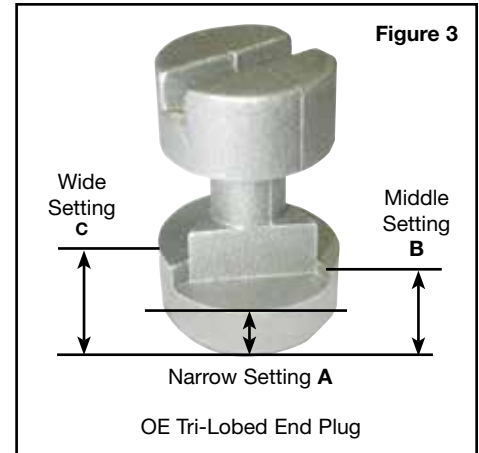

4. Installation & Assembly

- a. Install appropriate number of selective shims (**Step 3**) over Sonnax valve stem (**Figure 4**).
- b. Insert Sonnax sleeve/valve assembly into bore. Sleeve should be installed with open end outboard. Valve should be installed with spring stem outboard.
- c. Insert Sonnax spring over valve spring stem.
- d. Insert Sonnax end plug into bore and retain with saved OE retainer.

NOTE: Sonnax end plug can be swapped end for end for best fit of sleeve in bore.

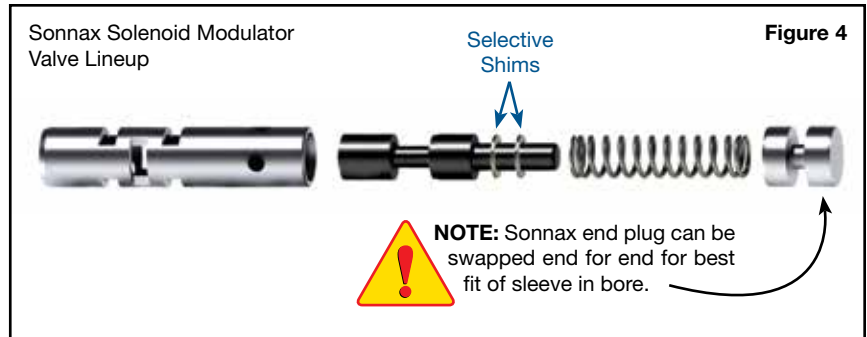

4. Final Testing

Due to the design changes on the Sonnax sleeve and valve, vacuum testing at the inboard port is not a valid sealing test.