

## GM 4L60-E, 4L65-E

### Smart-Tech® Input Housing Kit with Heavy Duty Input Shaft

**Part No.**  
**77733-11KA**

- Smart-Tech® Input Housing with 300mm Non-Reluctor Style Input Shaft Assembly
- PTFE Impregnated Rear Stator Support Bushing
- Overrun Piston Inner Seal
- Overrun Piston
- 3-4 Clutch Apply Plate
- 3-4 Clutch Return Springs (10)
- Bolt-on Anchor Plate
- Overrun Piston Outer Seal
- Socket Head Cap Screws (15)

Patent No. 8,857,592

**NOTE:** Fits 300mm non-reluctor units only.

Also Available

**Forward Piston Installation Tool  
77764-INSTL**

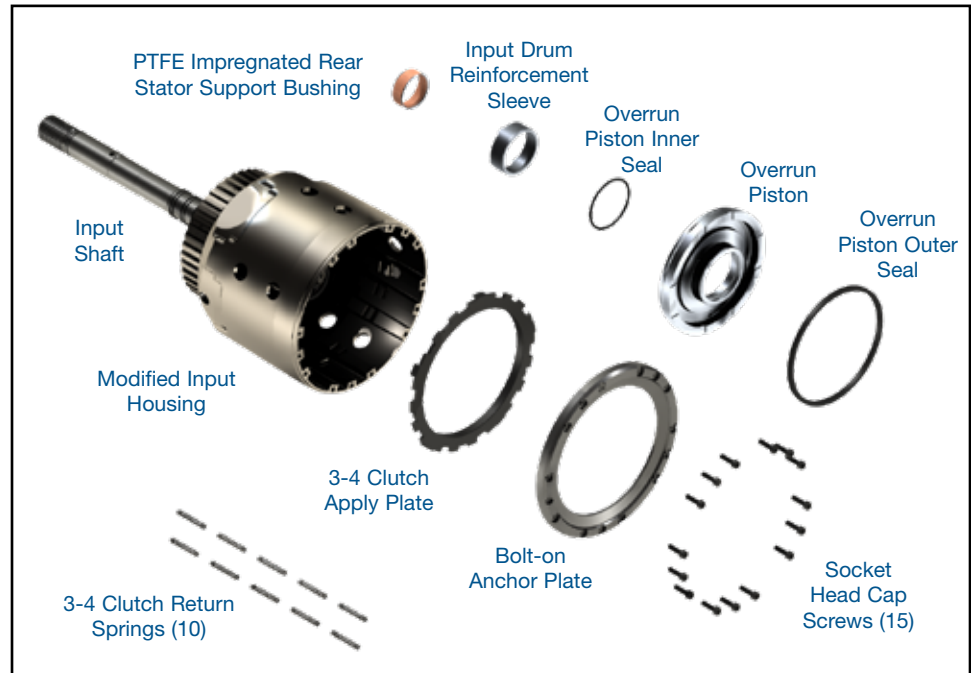

#### Verify Input Shaft Compatibility

Sealing ring location should be the same as the original shaft for the transmission being worked on. Measure from bearing spacer surface to middle of the front sealing ring groove (Figure 1). Distance of 76mm (2.992") verifies early seal ring spacing and use of 77733-11KA for application. Distance of 71.5mm (2.815") verifies late seal ring spacing and use of 77733-12KA for application.

#### Use '91-Later Apply Ring

Requires '91-later 3-4 apply ring stamped "7" with dimension "A" of 3.671 to 3.682" (Figure 2).

#### Use '87-Later Ring Gear

Requires '87-later ring gear. The correct spline length is 1.675" (Figure 3).

#### Use Stamped Steel Forward Piston

This kit must be used with a '97-later stamped steel forward piston (Figure 4). It cannot be used with aluminum forward piston or Sonnax billet forward piston 77764-01.

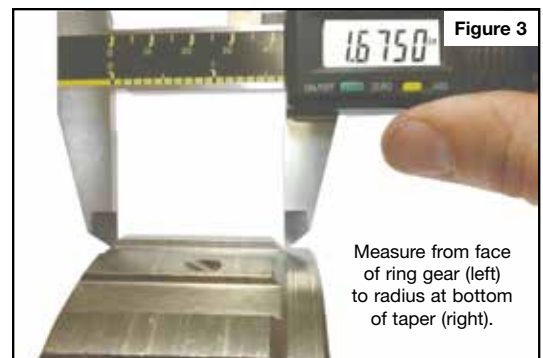
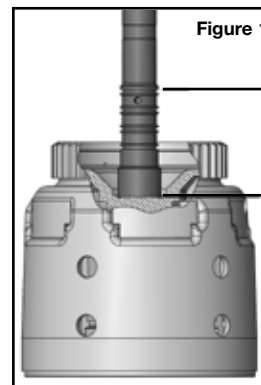

### Use Dual-Cage Return Spring

This kit must be used with a '97-later dual-cage return spring (24206085), identified by stamped retainer on both ends of the springs (**Figure 5**). Although not required, the '96-earlier style return spring is about 10% stronger and preferred for high RPM applications. To use the early-style return spring, swap the bottom spring retainer from a '97-later spring onto the '96-earlier spring.

### 1. Clutch Selection

This kit has approximately 5mm more room to allow for additional clutch combinations. The recommended combinations are:

- Eight .067" frictions with seven .095" steels
- Nine .062" frictions with eight .077" steels

### 2. 3-4 Clutch Pack Installation & Assembly

Use normal assembly procedures for pistons, overrun clutches, forward clutches and input sprag. Sonnax forward piston installation tool 77764-INSTL is available to assist installing forward piston over installed reinforcement sleeve.

**NOTE:** A lip seal is included for use with aftermarket gasket and seal kits that do not include this seal.

- Install the Sonnax apply plate, ensuring the five tabs securely fit over the OE 3-4 clutch apply ring.
- Install a friction plate against the face of the Sonnax apply plate.
- Install a steel plate against the friction plate. Continue alternating plates, ending with a friction plate on top.
- With the clutch pack installed, measure the clearance from the top friction to the end face of the housing. Measure in multiple locations to ensure an accurate reading. Clearance should be between .050" and .060" (**Figure 6**). Adjust clearance by substituting different thickness steel plates.
- Install 10 Sonnax 3-4 clutch return springs into the five OE spring retainers. These are required to keep the apply plate released and minimize drag from clutches.
- Slide the spring retainers into the housing, with springs and retainers oriented as shown (**Figure 7**).
- Install the Sonnax bolt-on anchor plate onto input housing, aligning the bolt holes with the threaded holes in the input housing.
- To ensure the correct torque spec and thread locking, all threads should be clean and dry prior to assembly. Apply a drop of Loctite® Threadlocker 262 or similar product to the threads of each socket head cap screw. Install all screws through the backing plate into the threaded housing and lightly tighten each screw.
- Torque each fastener to 51 in-lb. Work around the housing in a crisscross (star) pattern to ensure even pressure on the backing plate.

### 3. Final Verification Step

Air test assembled housing (**Figure 8**).

### 4. PTFE Bushing Installation

- Remove rear stator bushing, taking care not to damage bushing bore.
- Install Sonnax PTFE-coated bushing using appropriate driver tool.

