

Oversized TCC Regulator & Accumulator Valve Kit

Part No.

44912-12K



- TCC Regulator Valve
- Accumulator Valve
- Accumulator Spring Retainer

NOTE: Does not fit '19-later 68RFE.

Tool Kit

Part No.

F-44912-TL12



- Reamer 1
- Reamer 2
- Reamer Jig
- Reamer Stop
- Guide Pin

NOTE: Sonnax "F-Tool" kits designed to service a specific bore require the VB-FIX, a self-aligning valve body reaming fixture. More information and instructions can be found online at www.sonnax.com.

Chrysler 45RFE, 545RFE, 65RFE, 66RFE, 68RFE

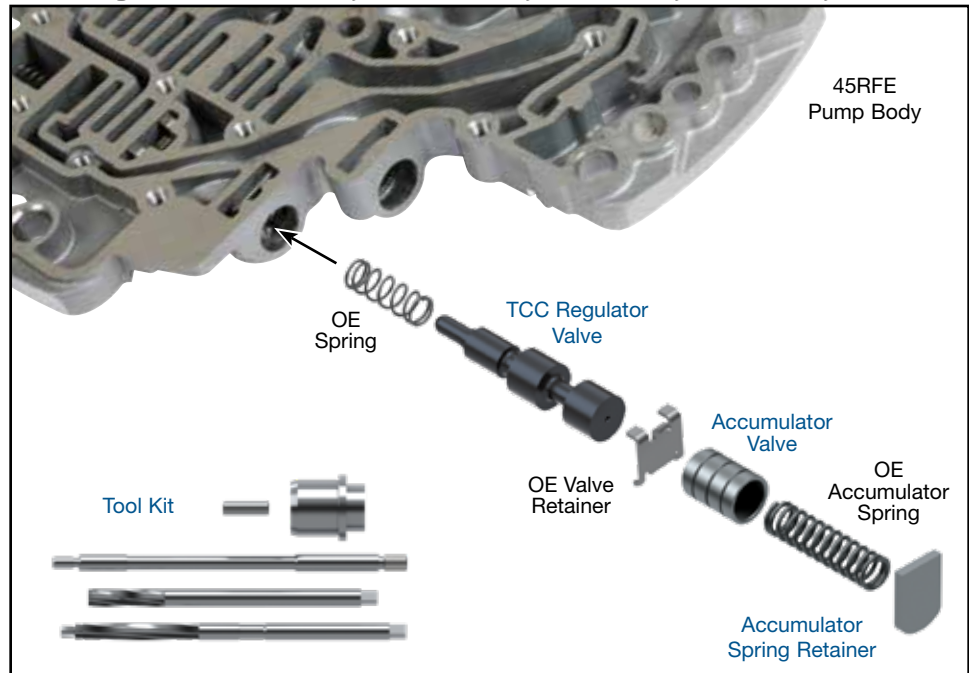

1. Disassembly

- Remove and discard OE accumulator spring retainer and accumulator valve.
- Set aside the OE accumulator spring for reuse.
- Remove and discard the OE TCC Regulator valve.
- Set aside OE TCC Regulator valve spring and retainer for reuse.

2. Bore Reaming

Ream TCC regulator/accumulator bore (for reaming instructions/reamer care, please visit www.sonnax.com). Sonnax reaming tool kit **F-44912-TL12** and **VB-FIX** are required for this operation.



NOTE: This repair requires two reamers and a reamer stop. The reamer stop is used for reamer #1 ONLY, failure to use the reamer stop could/will damage the pump core beyond repair.

- Insert the reamer stop into bore, ensure the reamer stop contacts bottom of bore.
- Ream the TCC Regulator/Accumulator bore using reamer marked #1, ream until reamer contacts reamer stop. Remove reamer #1 and reamer stop, be certain all debris has been removed from the pump while maintaining initial setup/alignment.
- Using Reamer #2, ream until reamer contacts bottom of bore.

3. Installation & Assembly

- Be certain all debris has been removed from the valve bore and pump.
- Reinstall OE TCC regulator spring, followed by Sonnax TCC regulator valve and the OE retainer.
- Install Sonnax TCC accumulator valve.
- Reinstall OE accumulator spring.
- Secure with Sonnax accumulator spring retainer.

4. Final Testing

Vacuum testing at the port(s) indicated holds the recommended minimum 18 in-Hg.

