

## Pressure Regulator Isolator Valve Kit

Part No.

**144510-15K**

- Valve
- Sleeve

### GM 6T31/35/41/46/51 (Gen. 3 6T40)

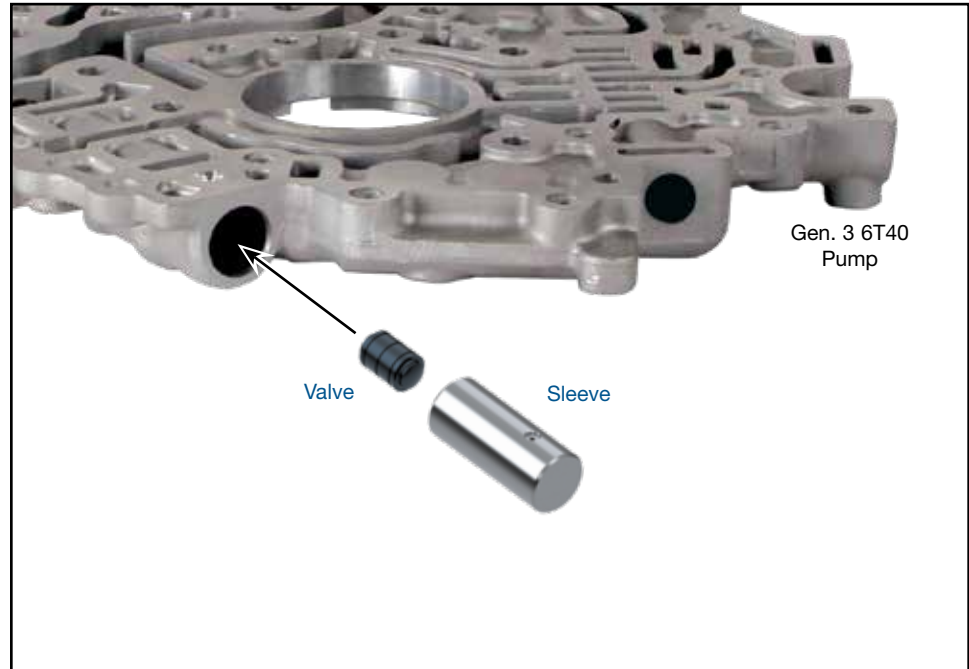

#### 1. Disassembly

- Remove OE retainer pin and keep for reuse.
- Remove OE pressure regulator isolator valve and sleeve assembly and discard.

#### 2. Installation & Assembly

- Clean the bore thoroughly.
- Install Sonnax pressure regulator isolator valve and sleeve.
- Reinstall OE retainer pin.

#### 3. Final Testing

Vacuum testing at the port(s) indicated holds the recommended minimum 18 in-Hg.

