

Shuttle Valve Kit

Part No.

154740-09K

- Valve
- Sleeve

GM 8L45, 8L90

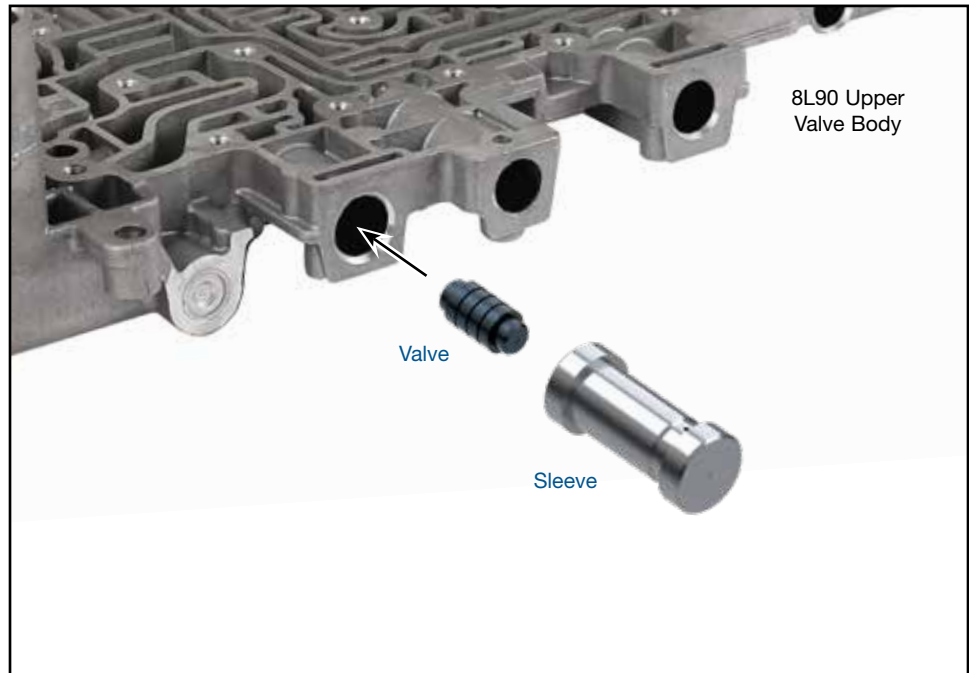

1. Disassembly

- Remove and discard OE shuttle valve assembly.
- Save OE retainer clip for reuse.

2. Installation & Assembly

- Install Sonnax shuttle valve and sleeve.
- Reinstall OE retainer clip to secure the sleeve and valve in the bore

3. Final Testing

Vacuum testing at the port(s) indicated holds the recommended minimum 18 in-Hg.

