

Performance Converter Kit

Part No.

AL-RK-5

- Front Cover
- Thrust Washer
- Clutch Plate with Internal Splines
- Clutch Plate with External Splines
- Damper Assembly
- Seal PTFE
- Energizer Ring
- Radial Lip Seal
- Turbine Hub Rivets (12)
- 26-Tooth Turbine Hub
- Stator Cap
- Bearing Turbine-side

Patent No. 7,770,704

NOTE: Fits '17-later.

Allison® LCT 1000 (Captive Clutch), Multi-Plate

Core: Allison LCT 1000 (Captive Clutch) • Dampened: Yes • Turbine Hub Input Spline Count: 26

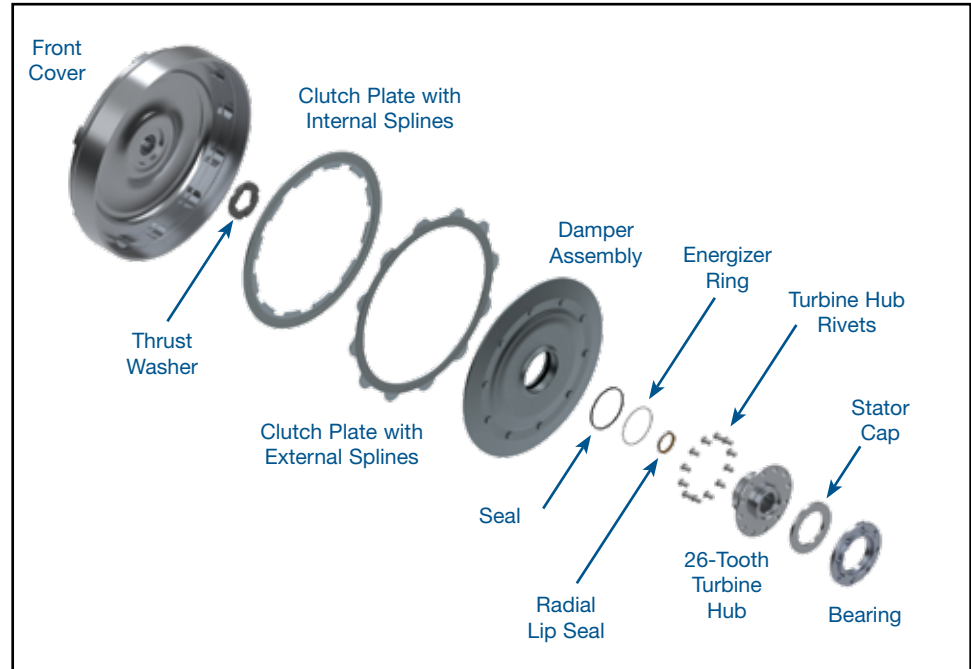

This performance converter kit combines the OE fluid coupling (impeller, stator and turbine) with all-new front cover, clutch plates, piston damper assembly and turbine hub to boost the converter capacity. The lockup clutch is not a salvaged OE clutch, it is a new and unique design.

1. Impeller Assembly

- Clean and inspect the OE impeller.
- If the blades are loose, either repair by brazing/welding or find a different impeller.
- Replace OE impeller hub.

2. Stator Assembly

- Disassemble the OE stator assembly.
- Clean and inspect the stator.
- Replace the stator cap, partially enclosed bearing and bearing race with those included with the kit.
- Replace the rolls, springs, races and bearings.

3. Turbine Assembly

- Remove the OE rivets and separate the turbine hub from the turbine.
- Clean and inspect the turbine. If any blades are loose, repair by brazing/welding or find a different turbine to use.
- Install the new turbine hub from the stator side and install new rivets. Weld the turbine hub in on high torque applications for extra security.
- Install the energizer ring (O-ring) into the groove on the turbine hub, then the PTFE ring in the same groove.



NOTE: The OE converter uses a thrust washer between the turbine and OE piston. This thrust washer should NOT be used when assembling the Sonnax multi-plate converter clutch kit.

- Install the radial lip seal with the metal clad side out toward the front cover, until it bottoms in the turbine hub bore.

4. Measure & Set Clutch Release Clearance

The clutch release clearance should be measured and adjusted as necessary.

- Measure from the piston stop of the turbine hub to the thrust face of the washer (Measurement "A" in **Figure 1**).
- Place the clutch plates and piston into the front cover (**Figure 2**). Measure from the inner lip of the piston to the thrust face of the front cover (Measurement "B" in **Figure 2**). The difference between the two measurements (A minus B) is the amount of clutch release clearance. It is recommended to set clutch release clearance between .040-.060".
- If there is too much clutch release clearance, machine the thrust surface of the front cover by the amount that you want to reduce the clutch release clearance (**Figure 3**). Make sure to maintain a RA 16 micro-inches surface finish and keep the thrust surface parallel to the mounting pads within .002". If you want to increase the amount of clutch release clearance, machine the lockup surface of the front cover by the amount you want to increase the travel. Make sure to keep the surface finish better than RA 20 micro-inches and parallel to the mounting pads (see "A" in **Figure 4**) within .003".
- After machining the front cover, re-measure A and B measurements and verify clutch release clearance.

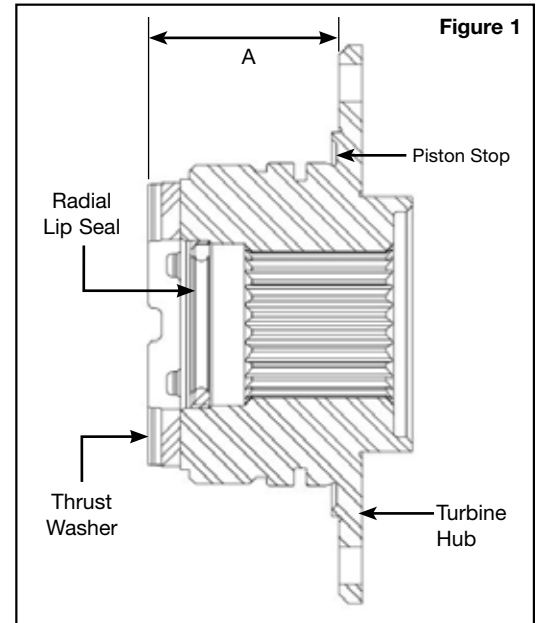

5. Final Assembly (see main photo for orientation)

- Install the thrust washer into the cover.
- Drop the internally splined (dual friction) clutch plate into the front cover.
- With the steel side towards the cover and the friction side towards the piston, install the externally splined (single friction) clutch plate into the front cover, rotating to engage the splines. Be sure this clutch plate fits freely without any binding in the cover.
- Install the piston and rotate it to engage the internally splined clutch plate.
- From this point on, assemble the converter as normal.
- Continue converter assembly. Endplay should be between .000-.010" and internal clearance should be between .100-.110" for maximum efficiency after welding. The stator should be able to turn freely. Pressure check, then balance finished unit.

