

Thermal Bypass Eliminator Kit

Part No.

72760-02K

- Eliminator Valve
- Spring
- Checkball
- Checkball Seat
- Retaining Ring
- O-Ring



NOTE: For use in OE part numbers 55111005AC and 68192000AA. These part numbers are located on OE cooler bypass valve housing.

Patent Pending

Chrysler 42RLE, 45RFE, 545RFE, 68RFE; Jatco/Nissan JF011E (REOF10A); Mercedes 722.6

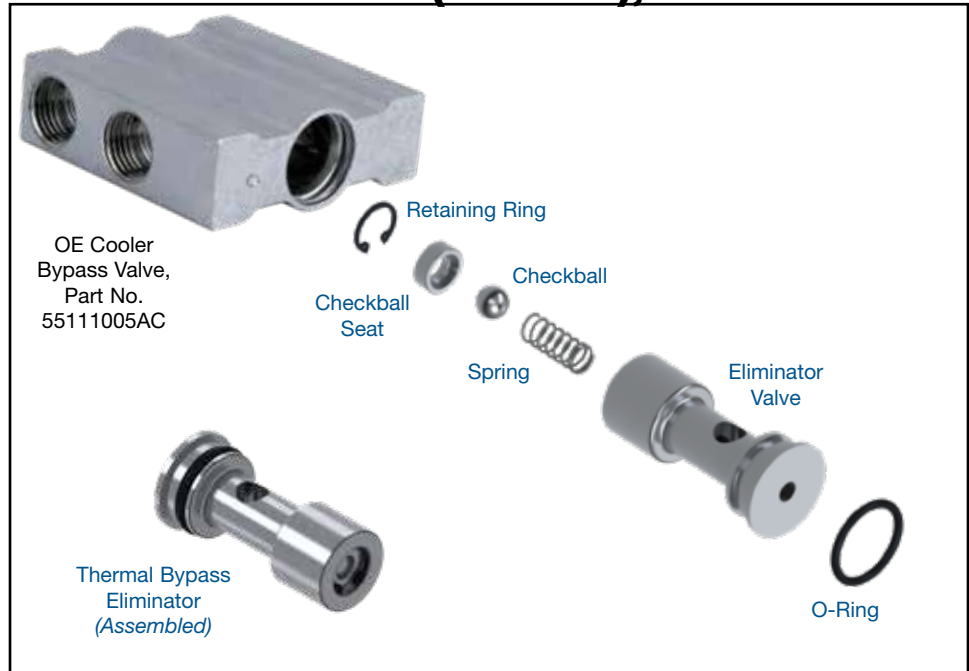

1. Assembly of Sonnax Thermal Bypass Eliminator

- Insert Sonnax spring into Sonnax eliminator valve bore.
- Place Sonnax checkball on top of Sonnax spring.
- Place Sonnax checkball seat on top of Sonnax checkball with the flat face facing up.
- Press down on the checkball seat and install Sonnax retaining ring into the groove.
- Install Sonnax O-ring into the O-ring groove.

2. Remove Parts from Vehicle

NOTE: In most applications, the housing is located towards the front of vehicle in close proximity to where the cooler lines enter the case. Depending upon vehicle, the OE cooler bypass valve thermal bypass bore may be accessible with snap ring pliers without removal from the vehicle. If accessible, clean cooler bypass valve and opening to thermal bypass bore with appropriate cleaner and follow steps 2b, 2c and 3a below.

- Remove OE cooler block from vehicle.
- Remove OE retaining ring and save for reuse.
- Remove and discard OE thermal bypass valve assembly.

3. Installation & Assembly

- Install Sonnax thermal bypass eliminator assembly and secure in place using the OE retaining ring.
- Reinstall block into vehicle.