

## Oversized Pressure Regulator Valve Kit

**Part No.**  
**85740-15K**



- Valve
- Spring
- End Plug
- O-Rings (2) 1 Extra

**NOTE:** Fits valves with overall length of 2.67" and outer spool length of .51".

## Tool Kit

**Part No.**  
**F-85740-TL15**



- Reamer
- Reamer Jig
- Guide Pin

**NOTE:** Sonnax "F-Tool" kits designed to service a specific bore require the VB-FIX, a self-aligning valve body reaming fixture. More information and instructions can be found online at [www.sonnax.com](http://www.sonnax.com).

## Chrysler 948TE; Honda/Acura, 9-Speed; ZF9HP48

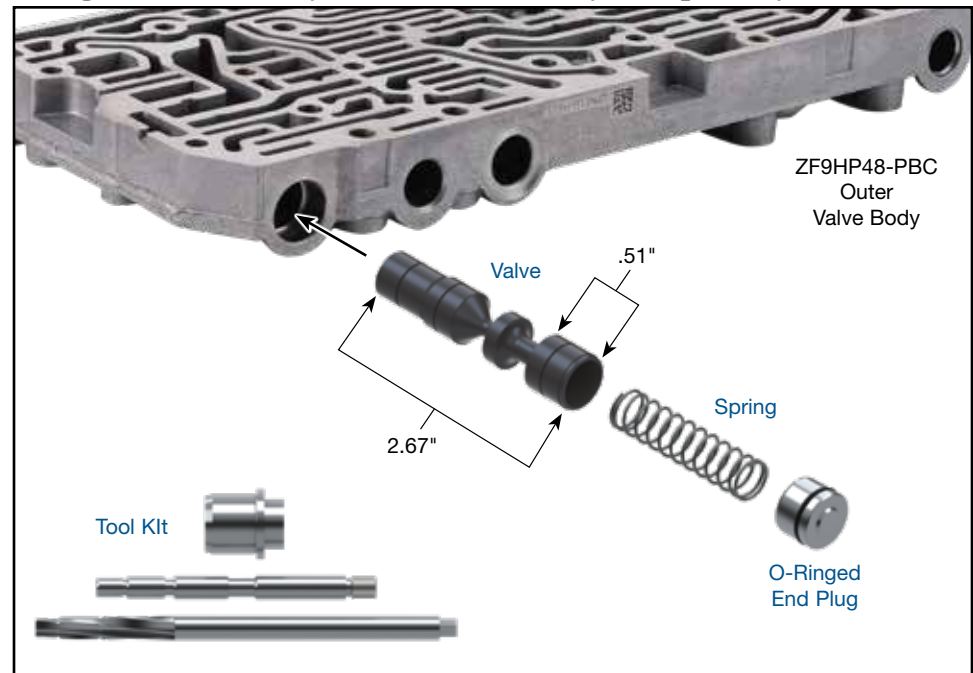

### 1. Disassembly

- Remove and discard OE spring, valve and end plug.
- Keep OE retainer for reuse.

### 2. Bore Reaming

Ream pressure regulator bore (for reaming instructions/reamer care, please visit [www.sonnax.com](http://www.sonnax.com)). Sonnax reaming tool kit **F-85740-TL15** and **VB-FIX** are required for this operation.

### 3. Installation & Assembly

- Be certain all debris has been removed from the valve bore and valve body.
- Install the Sonnax oversized pressure regulator valve and spring.
- Install O-ring in O-ring groove on endplug and roll to size.
- Use Sonnax Slippery Stick **O-LUBE** to lubricate end plug and bore entrance.
- Install O-ringed end plug and secure in place with OE retainer.

### 4. Final Testing

Vacuum testing at the port(s) indicated holds the recommended minimum 15, 18 and 20 in-Hg (**Figure 2**).

