

## Adjustable Rear Servo Pin Kit

### Part No.

# 34912-01K

- Servo Pin
- Screw
- Washers (4) Small
- Washer Large
- O-Rings (2) 1 Extra

**NOTE:** Fits all TH400 and '95-earlier 4L80-E. OE part nos. 8624140, 8627193, 8624141, 8627194, 8627195

## GM TH400, 4L80-E

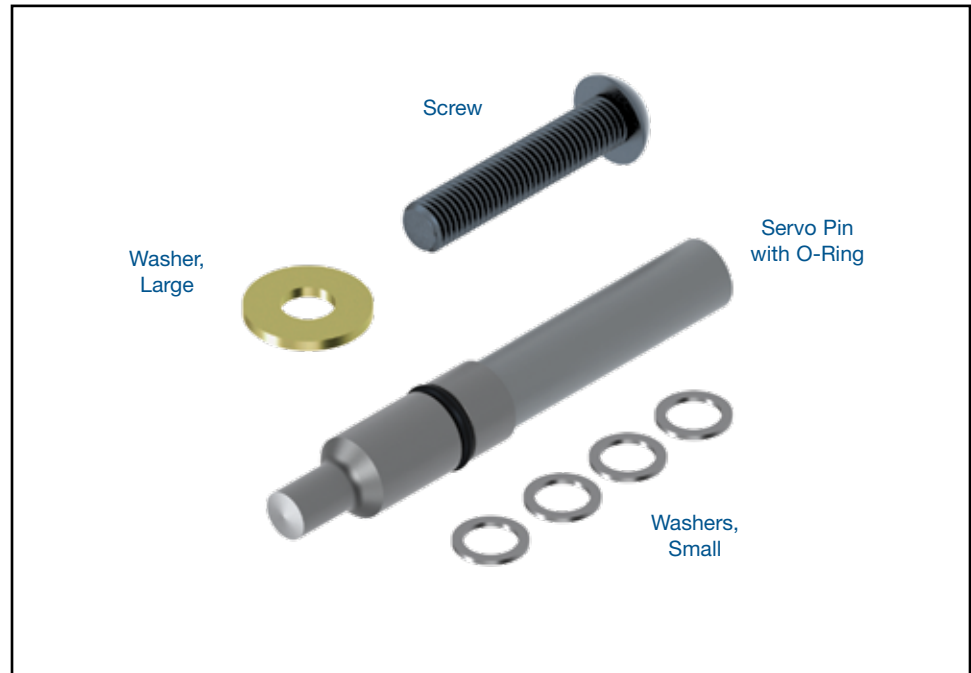

**NOTE:** If using an OE servo piston ('95-earlier 4L80-E or TH400), carefully inspect the aluminum casting for any indication of cracking. If the servo piston is damaged replace with Sonnax servo piston **34914-01**. Determining the servo travel and required pin length can be accomplished several ways.

### 1. Disassembly

- a. Remove OE components from the servo piston.
- b. Keep servo piston, spring, and spring retainer cup for reuse while discarding the rest (**Figure 1**).

### 2. Preparation

- a. Chamfer the case pin bore so it won't damage the pin O-ring during installation.
- b. Lubricate the case pin bore.

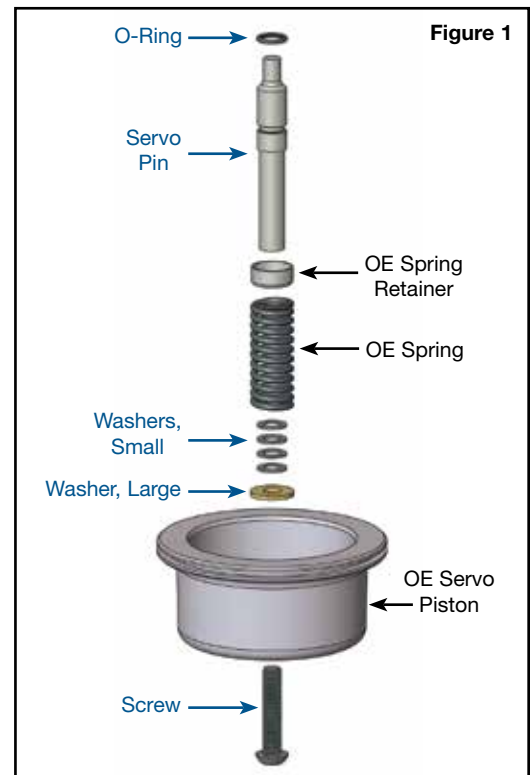

### 3. Installation

- Install Sonnax screw through OE servo piston from the backside (**Figure 2**).
- Install Sonnax large washer over the tip of Sonnax screw, within the servo piston (**Figure 3**).
- Install the required number of Sonnax small selective washers to set the desired pin length (**Figure 3**).  
**NOTE:** Small washers are not required and may not be necessary for your length.
- Install OE spring retainer cup and spring over Sonnax servo pin (**Figure 4**).
- Apply a drop of Loctite<sup>®</sup> 263 Threadlocker or equivalent product to the exposed threads of the screw. Install and tighten the servo pin onto the screw until the pin is bottomed against the small washers. The spring will touch the large washer first, but will compress as the pin is tightened. An impact driver is suggested (**Figure 5**).
- Install Sonnax O-ring into the groove on servo pin (**Figure 6**).

