

GM 4L60, 4L60-E, 4L65-E, 4L70-E

Input Housing Overrun Sleeve Kit

Part No.

77733-51KA

- Overrun Piston
- Overrun Reinforcement Sleeve
- Outer Overrun Piston Seal
- Inner Overrun Piston Seal

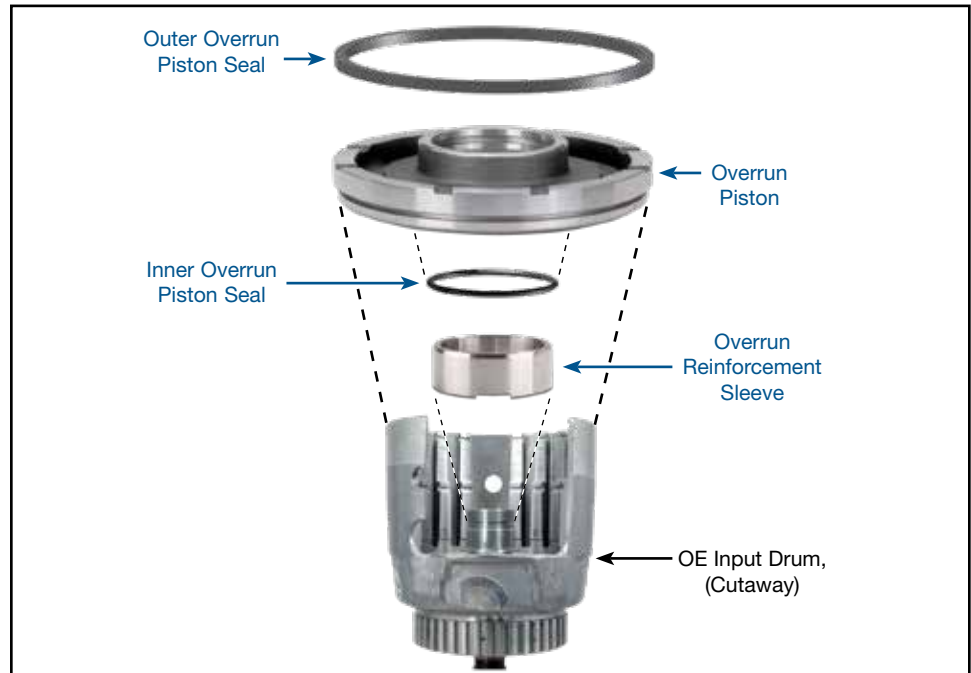

Use Stamped Steel Forward Piston

This kit must be used with a '97-later stamped steel forward piston or the aluminum piston in Sonnax forward sleeve kit 77733-52K. It cannot be used with '96-earlier OE cast aluminum forward piston or older Sonnax billet forward piston 77764-01.

Use Dual-Cage Return Spring

This kit must be used with a '97-later dual-cage return spring (24206085), identified by stamped retainer on both ends of the springs (Figure 2). Although not required, the '96-earlier style return spring is about 10% stronger and preferred for high-RPM applications.

To use the early-style return spring, swap the bottom spring retainer from a '97-later spring onto the '96-earlier spring.

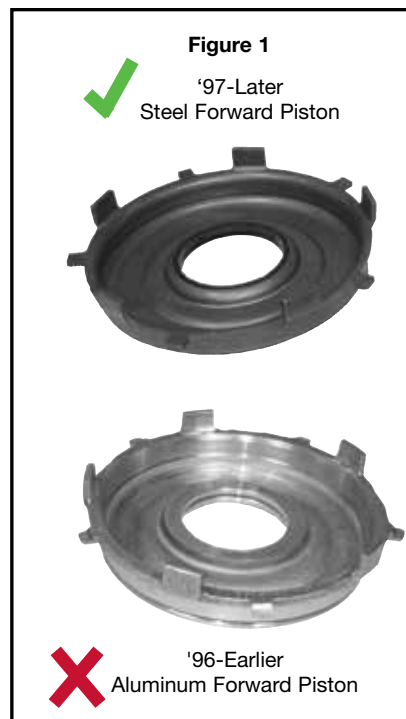

1. Sleeve Installation

- Set the input drum into a suitable press. Support the aluminum housing as indicated (**Figure 3**) using an appropriate sized tube or a spare (not to be reused) 4L60 stator shaft and selective spacer (with bearing left out).



CAUTION: Failure to support the drum as indicated can result in damage to the housing.

- Coat the inside of the sleeve with green Loctite[®] 609. Align the notch in the sleeve with the overrun feed hole in the housing (**Figure 4**). Set the sleeve into position on the input drum, keeping the notch in the sleeve aligned with the overrun feed hole in the housing.
- Using the press, install sleeve until just barely seated. Do not seat sleeve with the full force of the press since excessive pressure will ruin the housing. Do not hammer or pound the sleeve into place.
- Verify overrun feed hole is not blocked by the sleeve.

2. Input Drum Assembly

Assemble input drum as usual.



CAUTION: See notes on page 1 regarding piston and return spring.

