

Stator Support Bushing

Part No.

144036B

• Bushings (5)

WARNING: The stator tube bore is tapered in 6F35 units due to OE manufacturing conditions. The taper must be removed before installing Sonnax bushing. If taper is not removed, bushing retention will be too low, resulting in spinning and catastrophic failure.

CAUTION: Use of an arbor press is required for correct installation. Do not use a hydraulic press or a bushing driver/hammer to install, as doing so may distort the bushing and cause fitment issues.

NOTE: Machining is required on 6F35 units only.

Ford 6F35 (Gen. 1, 2 & 3); GM 6T40 (Gen. 1 & 2)



Stator Support Bushing

1. Disassembly

- Remove stator support tube assembly from pump.
- Remove lip seal and worn bushing from stator support tube.
- Measure inside diameter of bore (Figures 1 & 2). Bore will measure about .916–.917" where indicated.
- For 6F35 units only, machine stator support tube to specification (Figure 2). The higher side of this tolerance is ideal.

CAUTION: Ensure qualified machinist is employed for this task, as machining errors may render the pump unusable.

- Clean stator support tube bore. Ensure all contaminants are removed from bore and all passages.

2. Installation & Assembly

- Press in Sonnax bushing.
- Reassemble stator support tube assembly with pump.

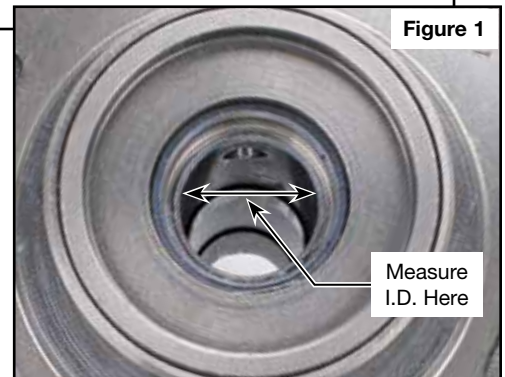

Figure 1

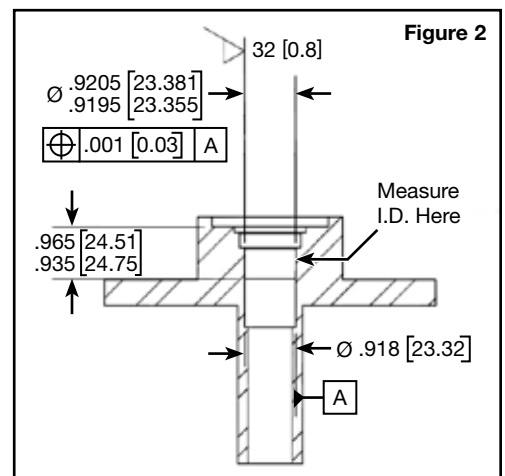

Figure 2