

4L60-E, 4L65-E Heavy Duty Remanufactured Valve Body

Fits '96-'08 units. Prevents input sprag and forward clutch failure by engaging overrun clutch in D4 1st, 2nd and 3rd Gears and D3 1st and 2nd Gears. Includes fluid rerouting for additional D4 protection & new servo cushion spring to reduce downshift clunk.

Part No. GM054-HD

- Remanufactured Valve Body
- Separator Plate
- Upper/Case Gasket Plate
- Lower/Valve Body Gasket Plate
- 1-2, 3-4 Accumulator Springs* (2)
- Servo Cushion Spring**
- EPC Solenoid Harness Adapter
- Line Pressure Booster Kit*** 4L60E-LB2
- Checkballs (8) .250"
- Boost Valve Spacer '96-'03 pump

NOTES: The components included in this heavy duty remanufactured valve body may be protected by patents pending or patent numbers 6,619,323, 6,990,966, 7,104,273.

*The two accumulator springs are the same, colors may vary. These springs provide a 'stock' shift feel to any previous alterations.

**It is necessary to install the servo cushion spring to help minimize a slight coast downshift feel difference or clunk.

***Includes large ratio boost valve assembly, two O-rings and pressure regulator spring.

****Appropriate modifications have been made to this product to ensure proper shift feel and performance. If upgrading the transmission with other products, do not alter this remanufactured valve body or warranty will be voided.

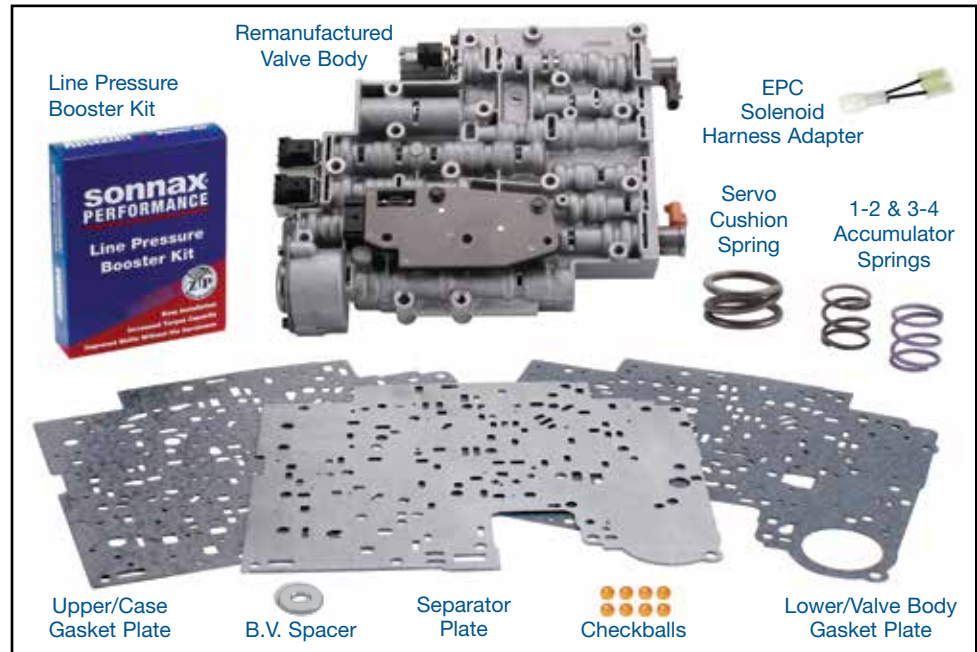

1. Pump Boost Valve Installation (Figures 1 & 2)

- Using eyelet snap ring pliers, remove OE retaining ring, boost assembly and springs from the pump.



WARNING: The OE boost valve sleeve comes in two lengths, depending on year. The '94-'04 boost sleeve is longer (1.907") and should be replaced with the Sonnax boost sleeve and included Sonnax spacer. If spacer is not installed when replacing 1.907" sleeves, transmission failure will result! For '05-later applications with 1.801" long OE boost sleeve, do not install Sonnax boost valve spacer.

NOTE: If this kit is being installed while the transmission is in the vehicle, it may be necessary to put some Transjel® on the inboard spool of the pressure regulator valve so it stays in the pump.

- Install Sonnax O-rings into the grooves on Sonnax boost sleeve. Lubricate with Sonnax Slippery Stick O-LUBE and roll on bench to size.

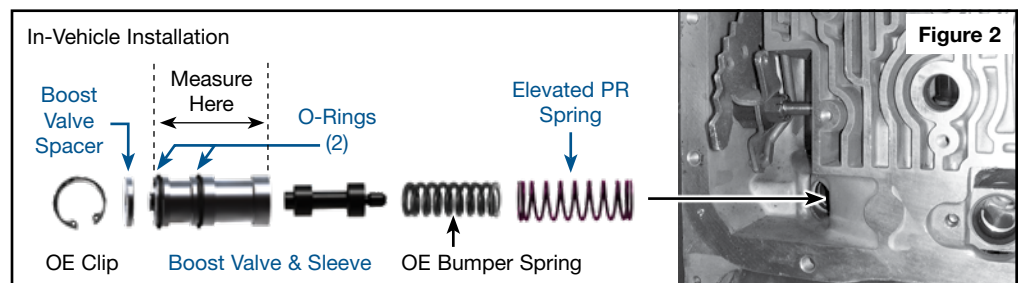
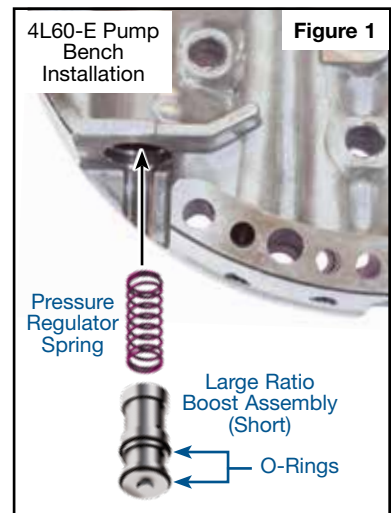

1. Pump Boost Valve Installation (continued) (Figures 1 & 2)

- c. Insert Sonnax valve into sleeve with nubbed end facing out.
- d. Nestle OE bumper spring into Sonnax elevated pressure regulator spring and insert into pump.
- e. Carefully insert Sonnax sleeve assembly into pump body with the open end toward the two springs, just deep enough to install Sonnax spacer and OE retainer clip.

NOTE: This boost valve assembly can also be used on '07-later pumps with the turbine speed sensor, without the spacer. You will have to remove the transmission and the pump to do this as the connector for the TSS is in the way of the boost valve.

2. Valve Body Installation

NOTE: The combination of included springs, line pressure booster and valve body updates provide heavy duty capability and firmer than OE shifts. However, if wanting to provide more noticeable firmness to shifts, enlarge the provided separator plate holes (Figure 3) to the indicated sizes.

- a. If the feedholes have been enlarged per note above and Figure 3, use a file and clean any sharp edges.
- b. Install upper and lower valve body gasket plates onto separator plate.
- c. Install Sonnax .250" checkball into the location in the case next to the 3-4 accumulator piston. Use a small amount of Transjel® to keep it in the case (Figure 4).
- d. Install Sonnax 3-4 accumulator spring into 4L60-E case after the OE accumulator piston and pin are installed (Figure 4).

NOTE: This will provide a 'stock' shift feel for previously modified springs or relaxed OE springs. If firmer shifts are desired, we recommend using the Sonnax HP-4L60E-01 spring.

- e. Install Sonnax 1-2 outer accumulator spring into the 1-2 accumulator housing. Install OE inner spring, then install OE piston and seal with spring pocket toward the springs (Figure 5).

NOTE: This will provide a 'stock' shift feel for previously modified springs or relaxed OE springs. If firmer shifts are desired, we recommend using the Sonnax HP-4L60E-01 spring.

- f. Install and align Sonnax separator plate and gaskets set onto the case using two 10mm headed bolts at the two noted holes in the separator plate (Figure 3).
- g. Install OE small stiffener plate, bolts and the 1-2 accumulator housing assembly. Torque bolts to 100 in-lb.
- h. Install six Sonnax .250" checkballs into the locations (Figure 6).

- i. Remove the two alignment bolts previously installed in the case. Install the manual valve link into the manual valve as the valve body is being installed onto the case. Install all of the retaining bolts in the valve body, finger tight.

NOTE: If these three 8mm headed bolts are installed incorrectly, it can lock the sun shell to the case, causing the transmission to bind in Reverse and 3rd Gear. Once all of the valve body retaining bolts have been installed, torque them to 100 in-lb, starting evenly from the center of the valve body working outwards (Figure 7).

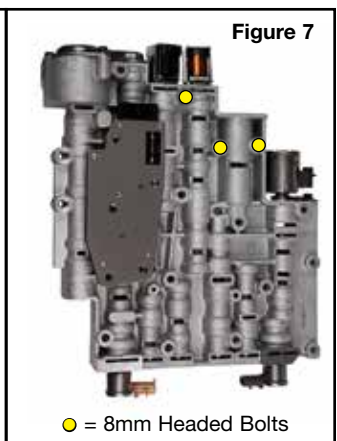
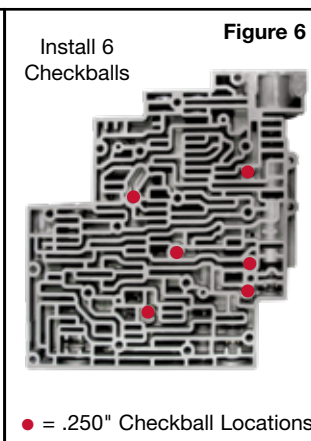
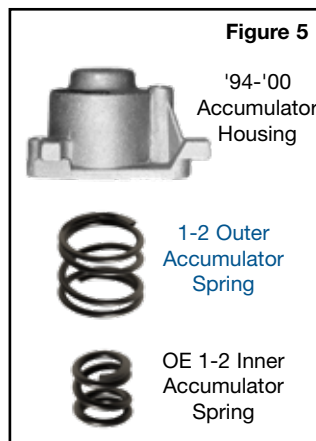
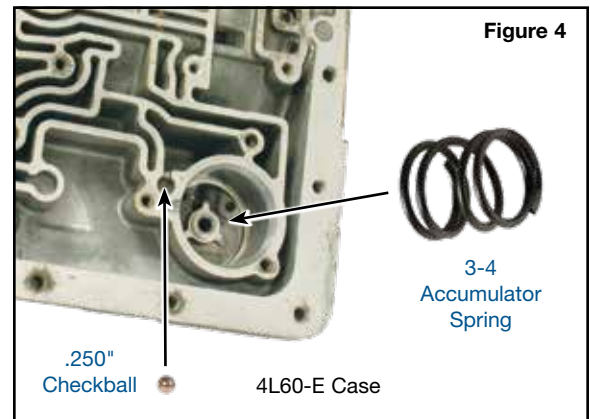
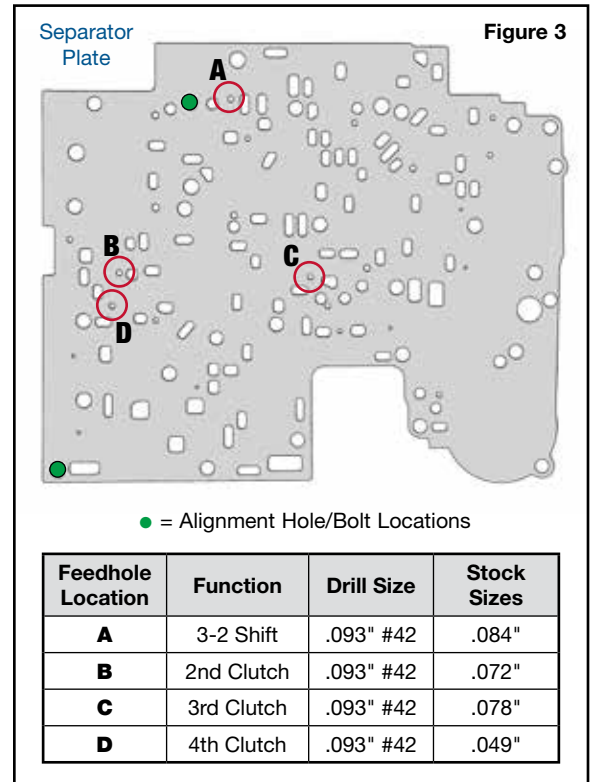

2. Valve Body Installation (continued)

j. After the valve body has been installed and all bolts have been torqued, install the wiring harness connectors to each individual solenoid and the pressure switch connector as well (Figure 8).

NOTE: In vehicles 2003-later, install an EPC jumper harness onto the EPC solenoid so the internal harness can connect to the EPC solenoid that is on the valve body.

3. Servo Cushion Spring Installation

- Install Sonnax servo cushion spring (Figure 9).
- Reinstall the conical OE bumper spring if used in your application.

4. Fluid Fill and Road Test

- Fill the transmission to factory specifications with OE compatible ATF.
- Let engine run to help warm transmission fluid to 185°.
- Verify level and do a thorough road test of at least 12-15 upshifts and downshifts through all four gears.

5. Transmission Diagnostic Tips

This remanufactured valve body has been through a rigorous inspection and rebuild process, then a comprehensive, functional hydraulic and electronic test to ensure it meets OE performance and quality. It is designed to eliminate many pressure-, shift- and converter-related complaints, but will not correct complaints that stem from other areas of the transmission.

See air test locations in the case (Figure 10) and an application chart (Figure 11) to help aid in diagnostics.

6. Common Failure Areas

- A 2-3 flared upshift and 3-4 clutch failure are common on these transmissions. Stator bushings and wear on the input shaft can attribute to these complaints.
- Torque converter clutch slip complaints and trouble codes are also common and can also be attributed to the same type of bushing failures.

Solenoid Identification Figure 8

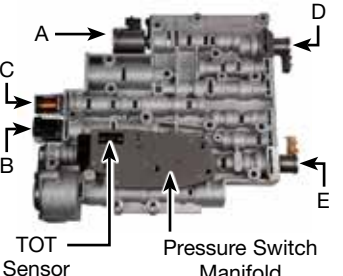

ID	Solenoid	Resistance
A	EPC	3-5 ohms
B	SSA	20-40 ohms
C	SSB	20-40 ohms
D	TCC PWM	10-15 ohms
E	3-2 Downshift PWM	20-30 ohms
F	TCC On-Off*	20-40 ohms

*TCC On-Off = Not Included

Figure 9

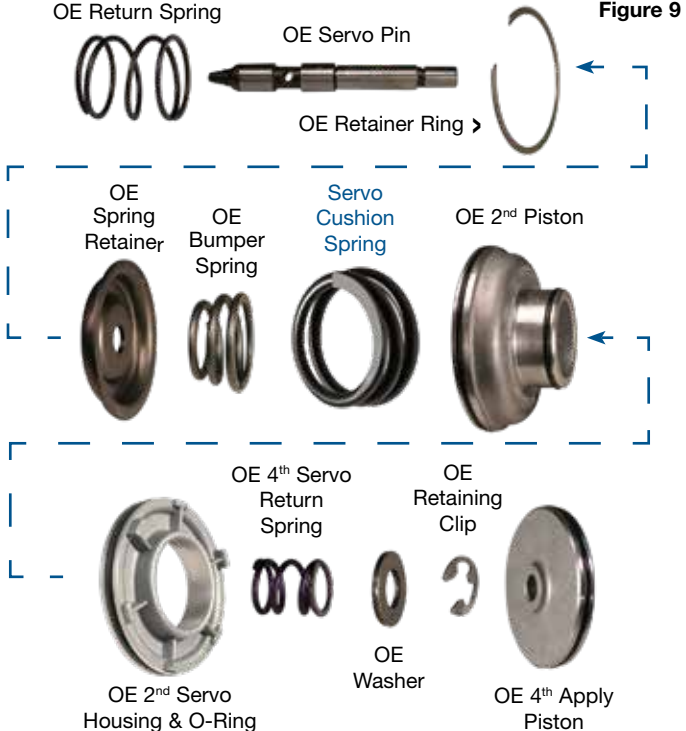

4L60-E Air Test Location Figure 10

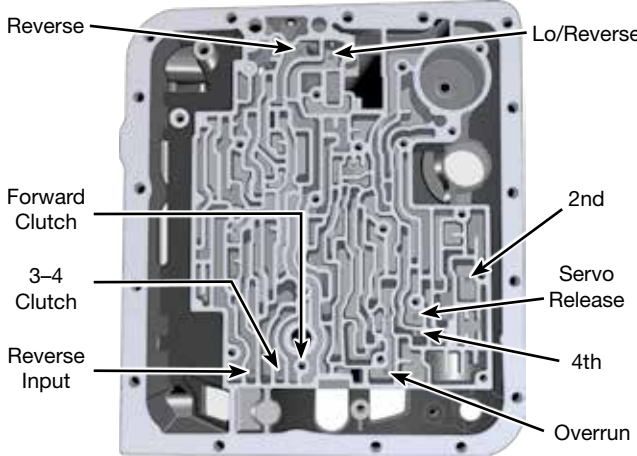

Solenoid and Apply Component Application Chart Figure 11

RANGE	GEAR	SHIFT SOLENOID		2-4 BAND	REV INPUT CLUTCH	OVER-RUN CLUTCH	FWD CLUTCH	FWD SPRAG	3-4 CLUTCH	LOW/REV CLUTCH
		A	B							
PARK		On	On							On
REV		On	On		On					On
NEUTRAL		On	On							
D4	1st	On	On			On	On	Hold		
	2nd	Off	On	On		On	On	Hold		
	3rd	Off	Off			On	On	Hold	On	
	4th	On	Off	On			On		On	
D3	1st	On	On			On	On	Hold		
	2nd	Off	On	On		On	On	Hold		
	3rd	Off	Off			On	On	Hold	On	
2	1st	On	On			On	On	Hold		
	2nd	Off	On	On		On	On	Hold		
1	1st	On	On			On	On	Hold		On
	2nd	Off	On	On		On	On	Hold		