

## Clutch Control Valve Bore Sizing Tool

Part No.

**105740-BST**

Recommended

### Allison® 10L1000; Ford 10R60, 10R80, 10R90, 10R140; GM 10L60/80/90 (Gen. 1 & 2)

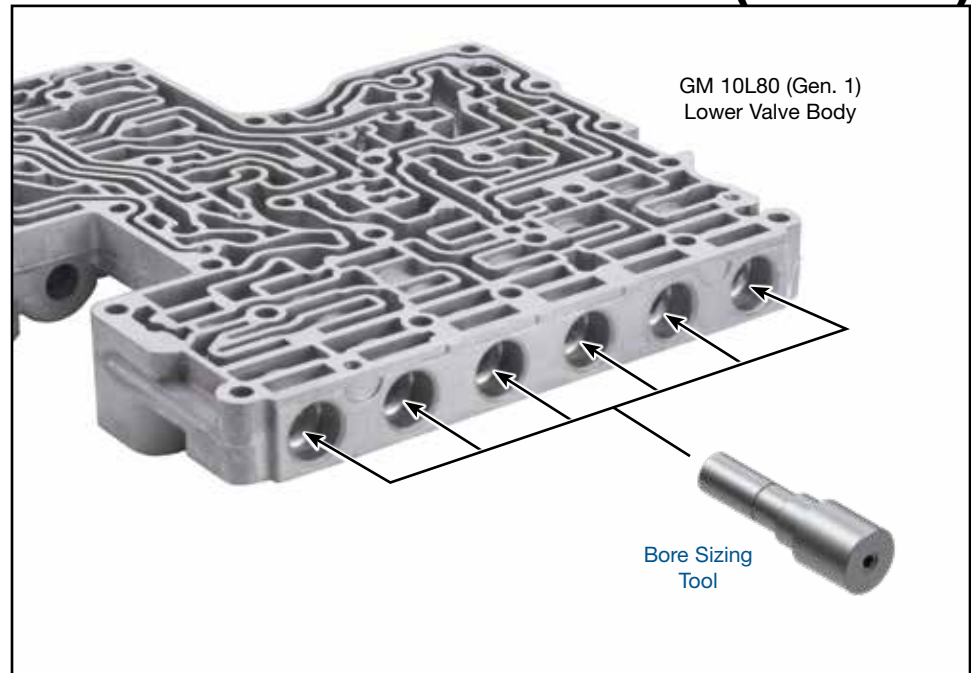

**WARNING:** Care must be taken when removing the valve to avoid damage. Sonnax recommends using a hand deburring tool such as NOGA SC8000 (available at MSC as part number 05752647) or similar to deburr the bore before removing the valve to avoid damaging it.

1. Lubricate the bore sizing tool with ATF.
2. Insert the bore sizing tool into the bore, pushing carefully until it bottoms out in the bore.
3. The tool should then be moved in and out of the bore, mimicking the stroking of the valve. Repeat this until bore sizing tool moves back and forth freely.

**NOTE:** The tool is tapped with a ¼-20 UNC thread for use with a slide hammer.

4. If the tool does not move freely, reinstall bore sizing tool and tap the sizing tool back and forth in the bore using a hammer and screwdriver inserted through the ports and into the tool grooves. This will smooth out any ridges in bore.