

## Ford 10R60, 10R80, 10R90, 10R140; GM 10L60/80/90 (Gen. 1)

### Oversized Main Pressure Regulator Valve Kit



**Part No.**  
**105740-20K**

- Valve Small Dia.
- Spring Red, Large Dia.
- End Plug 1 Extra
- O-Rings (2)

### Tool Kit



**Part No.**  
**F-105740-TL20**

- Reamer F-105740-RM20
- Reamer F-105740-RM21
- Reamer Jig
- Guide Pin

**NOTE:** Sonnax "F-Tool" kits designed to service a specific bore require the VB-FIX, a self-aligning valve body reaming fixture. More information and instructions can be found online at [www.sonnax.com](http://www.sonnax.com).

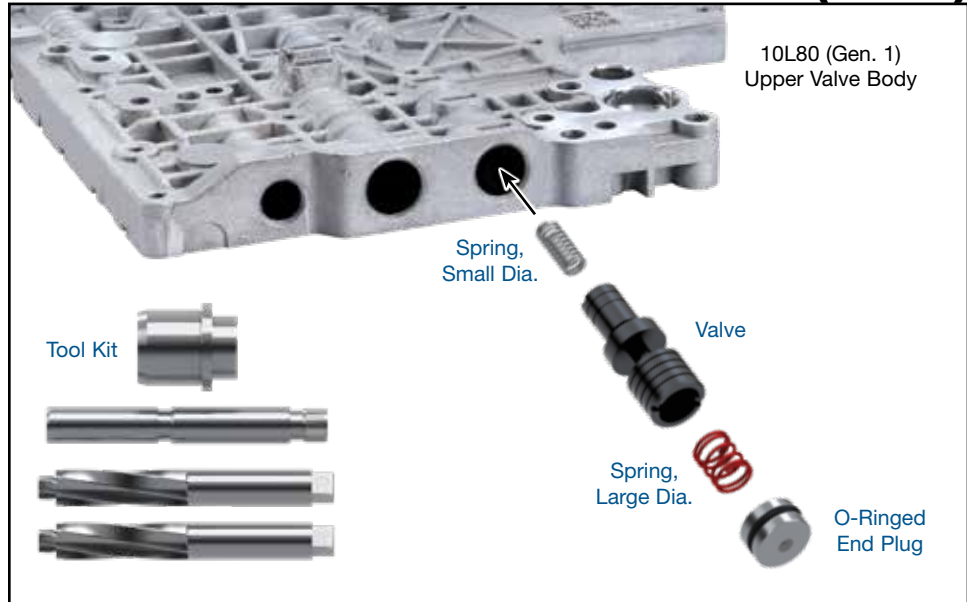

#### 1. Disassembly

- Remove OE retaining clip and save for reuse.
- Remove and discard OE end plug, large diameter OE spring, OE valve and small diameter OE spring.

#### 2. Bore Reaming

- Sonnax reaming tool kit **F-105740-TL20** and **VB-FIX** are required for this operation. For installation of **105740-20K**, use reamer **F-105740-RM20**.
- Ream main pressure regulator bore (for reaming instructions/reamer care, please visit [www.sonnax.com](http://www.sonnax.com)).

#### 3. Installation & Assembly

- Be certain all debris has been removed from the valve bore and valve body.
- Install Sonnax small diameter spring.
- Install Sonnax oversized valve.
- Install Sonnax large diameter spring.

#### 3. Installation & Assembly *continued*

- Install Sonnax O-ring into shallow groove of Sonnax end plug. Lubricate with Sonnax Slippery Stick **O-LUBE** and roll on bench to size the O-ring into the groove.
- Carefully insert Sonnax O-ringed end plug into the bore just far enough to reinstall the OE retainer.
- Reinstall OE retaining clip.

#### 4. Final Testing

Vacuum testing at the port(s) indicated holds the recommended minimum 18 in.-Hg.

