

TCC Boost Valve Kit

Part No.

823740-12K

- Spacer
 - Valve
 - Sleeve
- Selective

Subaru TR580

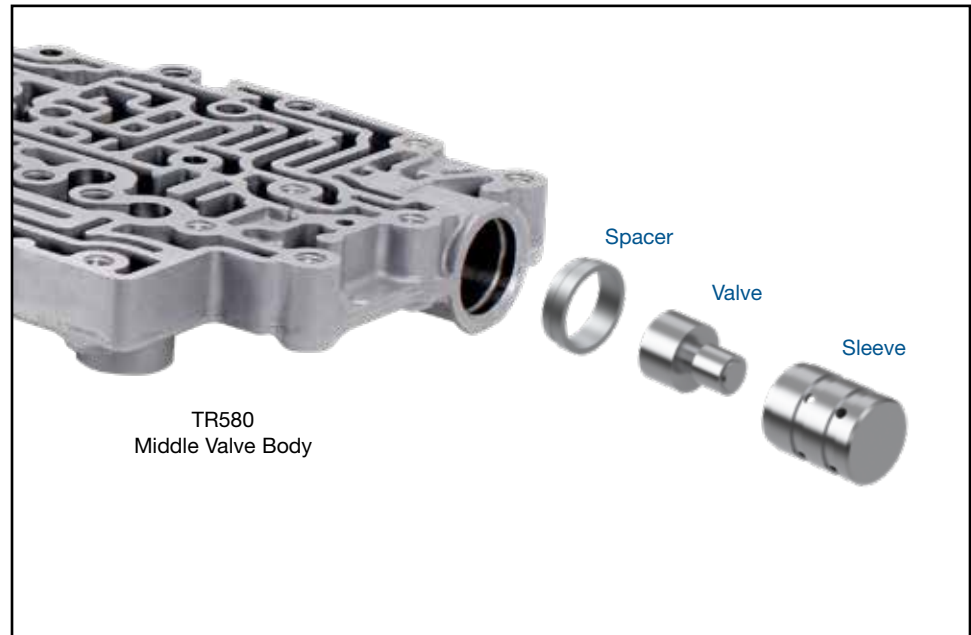

1. Disassembly

- Remove OE retaining clip and save for reuse.
- Remove and discard OE TCC boost valve and sleeve assembly.

2. Installation & Assembly

- Be certain all debris has been removed from the valve bore and valve body.
- Measure the depth of valve body boost sleeve bore.
 - If depth is longer than 1.5", install Sonnax spacer into the bore with the smaller outer diameter facing into the bore.
 - If depth is shorter than 1.5":
Do NOT install Sonnax spacer.
- Install Sonnax TCC boost valve and sleeve.
- Reinstall OE retaining clip to secure the boost valve and sleeve in the bore.

3. Final Testing

Vacuum testing at the port(s) indicated holds the recommended minimum 16 in-Hg (**Figure 1**).

