

## O-Ringed Shuttle Valve Kit

Part No.

**154740-30K**

- Valve
- Sleeve
- O-Rings (3)

1 Extra

## GM 8L45, 8L90

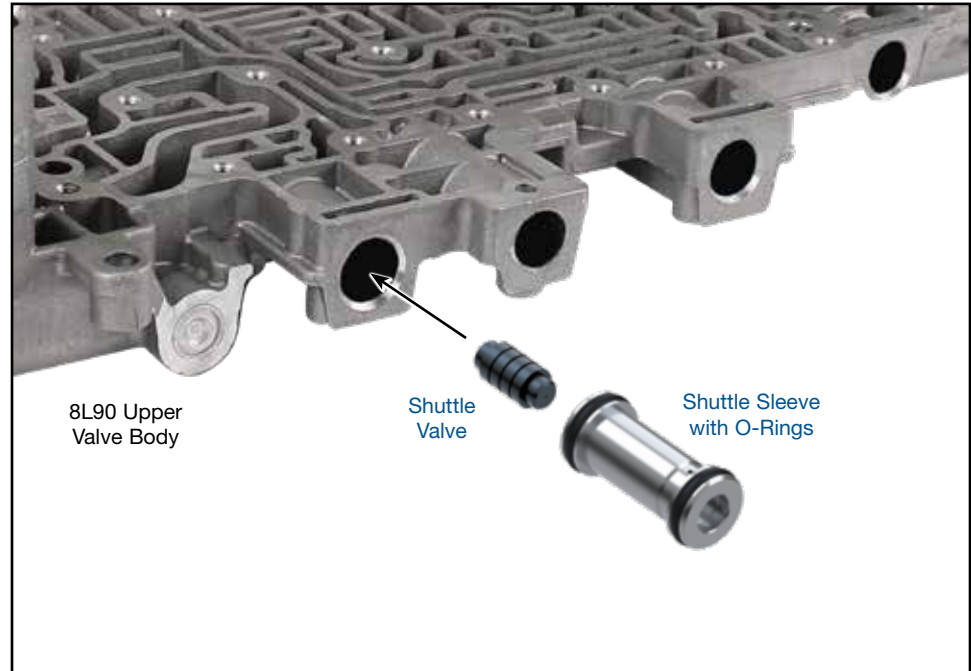

### 1. Disassembly

- Remove OE retainer clip and save for reuse.
- Remove and discard OE shuttle valve assembly.

### 2. Installation & Assembly

- Install the Sonnax O-rings on the shuttle valve and sleeve assembly.
- Lubricate O-ringed shuttle sleeve with Sonnax Slippery Stick **O-LUBE**.  
Roll on bench to size O-rings into grooves.
- Install the Sonnax shuttle valve and sleeve assembly into bore, open end of sleeve first.
- Reinstall OE retainer clip to secure the sleeve and valve in the bore.

### 3. Final Testing

Vacuum testing at the port(s) indicated holds the recommended minimum 16 in-Hg.

