

JMBV Performance Converter Kit

Part No.

GM-RK-23

- Front Cover
- Clutch Plate with External Splines
- Clutch Plate with Internal Splines
- Piston
- Rivets (8) 2 Extra



NOTE: The converter sticker codes found on 6L80/90 full size converters are not always consistent. In particular, the JMDZ code can be found on both gas and diesel types of these converters. Be sure to check bolt circle diameter and overall converter height to verify the Sonnax kit is designed for your application.

GM 6L80, 6L90 (300mm), Multi-Plate

Unit Size: 300mm • Core: GM 300mm • Dampened: Yes • Turbine Hub Input Spline Count: 36

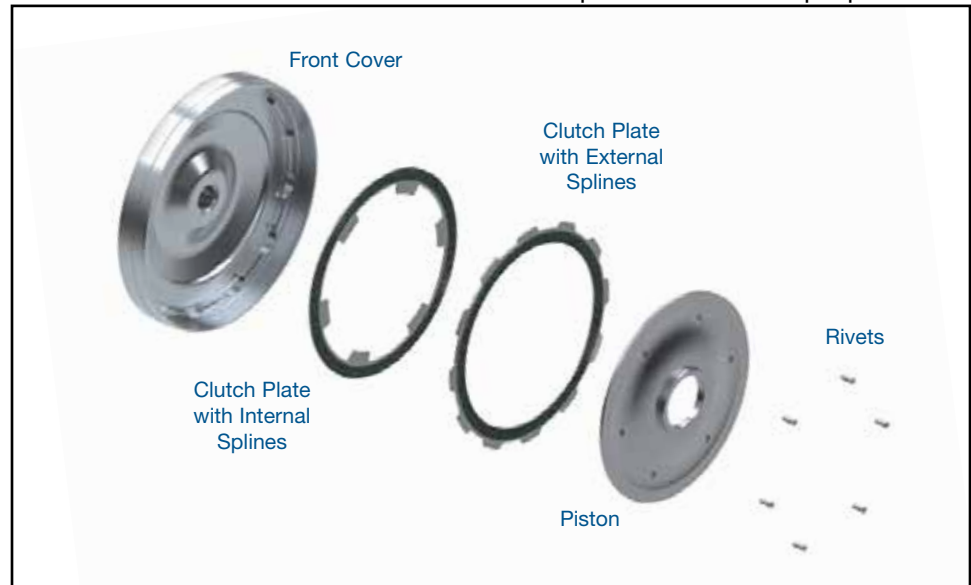

NOTE: Do NOT use the force of peening the rivet to clamp the pads together and against the piston. It is important to use an alternate clamping force to contact both the rivet pads and the piston before installing rivets.

1. Disassembly

- Cut the OE 6L80 (JMBV) torque converter apart.
- Inspect OE impeller hub and replace if necessary.
- Discard OE cover and keep the piston damper assembly.
- Remove OE damper assembly from the piston by removing the six rivets around the spring retainer plate.
- Inspect the top spring retainer plate and check for any damage and any cracks near the spring ends.

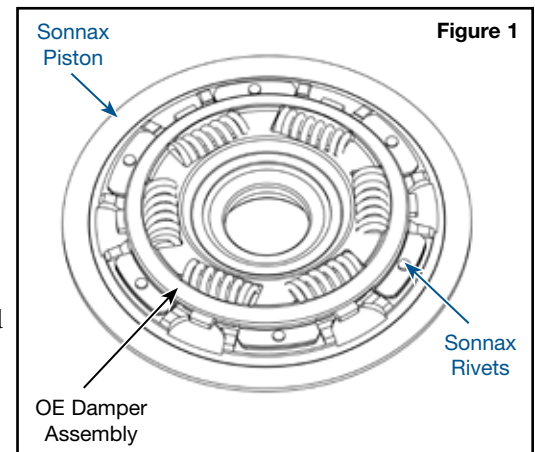

- If cracks are found replace this part with Sonnax **GM-DA-18** spring retainer plate.

2. Assembly

- Assemble OE damper assembly onto Sonnax piston using six Sonnax rivets (**Figure 1**).
- It is recommended to internally balance the piston damper with the turbine assembly.

2. Assembly (continued)

c. Assemble the two clutch plates and piston damper on to the cover and make sure the inner splines engage into the piston splines (**Figure 2**).



CAUTION: The earlier 6L80 (JMBV) converters did not have Sonnax **GM-WP-16** plastic washer between the turbine and piston and is required for this kit. The early 6L80 converter also had a thinner .179" thick needle bearings that mates with the early stator cap **GM-WA-28**. Mixing parts between the early and late converters may result in the incorrect overall height. Refer to the Sonnax 6L80/6L90 (300mm) web page for replacement parts.

- In this converter the clutch release clearance is the same as the endplay and must be between .015-.025".
- The overall height for the stock JMBV torque converter is 6.271" \pm .020" after welding.
- If the overall height needs to be increased use a Sonnax shim **GM-WS-25** (.020") or **GM-WS-26** (.030") between the impeller side stator cap and needle bearing.

