

Valve Body Casting Identification

Look for the machined-down boss on the upper valve body (**Figure 1**). Generally, if the “A” boss is machined down, this indicates an MYA/6L45 unit (see chart below). This identification system is not foolproof, because on some valve bodies none of the bosses are machined down (**Figure 2**). Also see other early vs. late and 6L45/50 vs. 6L80/90 application differences (**Figure 3**).

Machined-Down Boss on Upper Valve Body	Indicates Valve Body Unit*
“A” Boss ID	MYA/6L45
“B” Boss ID	MYB/6L50
“C” Boss ID	MYC/6L80
“D” Boss ID	MYD/6L90

*Note: This is a general rule to follow, but may not always be true. Sometimes no bosses are machined.

		Upper Casting		Center Support Feed Holes	Lower Casting	
		'10-Earlier	'10-Later		'10-Earlier	'10-Later
GM	6L45	9405	7114	Centered	9581	0945
	6L50	9405	7117	Centered	9581	0945
	6L80	9404	0955	Offset Front	9581	0945
	6L90	9404	0955	Offset Rear	9581	0945
BMW	6L45	1590		Centered	9581 or 6351	

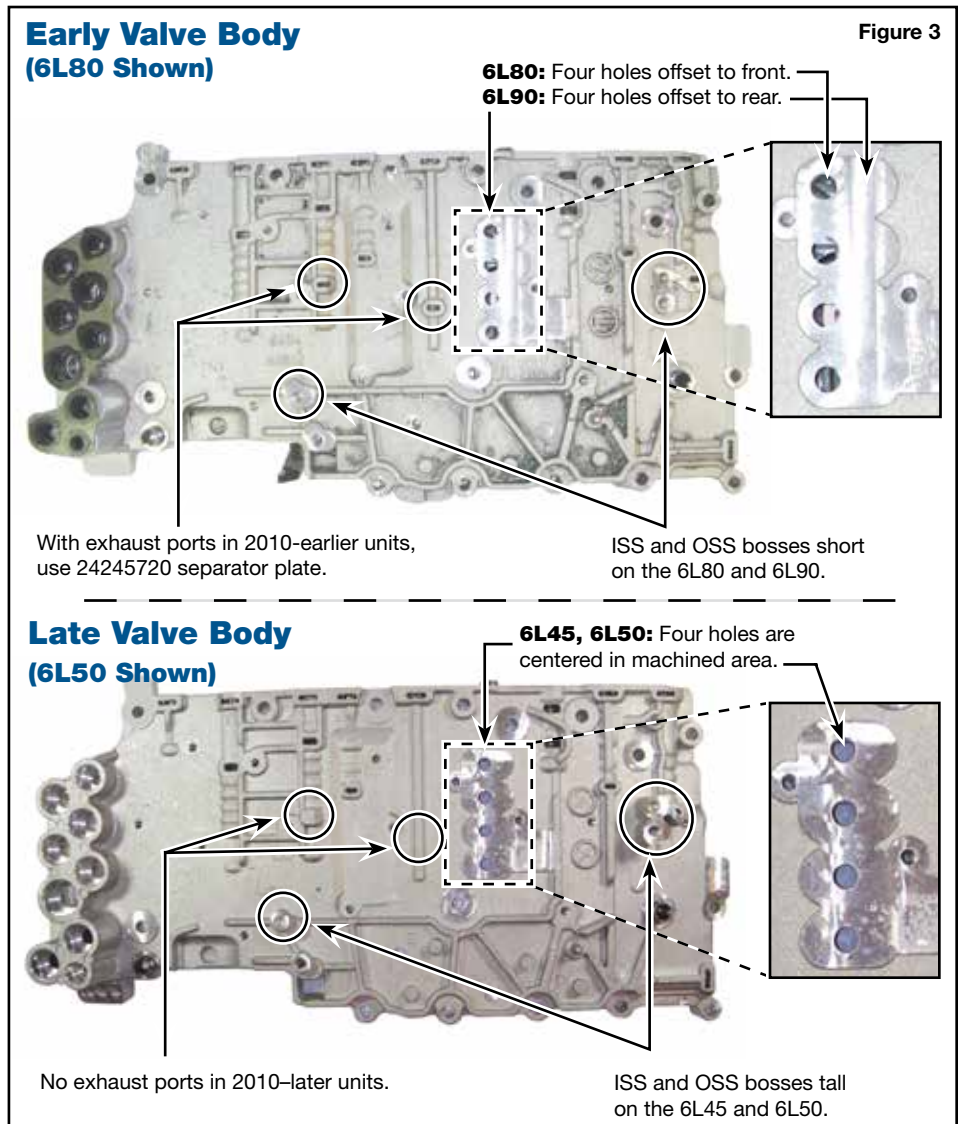
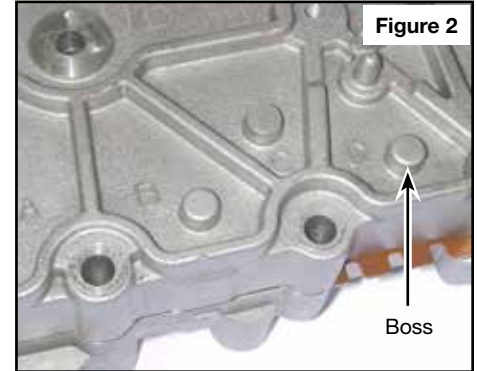
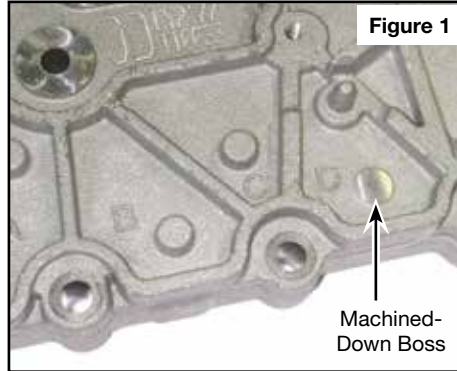

Separator Plate Identification

Clutch Select Spring Usage

Refer to A and B below and in illustration (Figure 4) to identify early 1st design plate that does not use supplied clutch select springs.



NOTE: All other plate designs can use supplied springs.

A. If Early, 1st design 6L80 plate 24246916 is equipped, REPLACE with Early, 2nd design plate 24245720 and install Sonnax clutch select valve spring kit 104740-02K.

B. When using Early, 2nd design plate (2010-Earlier, OE part #24245720): DO NOT install checkball #8.

#8 Checkball Usage

Reference images C and D (Figure 4) for orifice location and size in determining if #8 checkball is used.

See location of #8 checkball on 6L80/90 models only, when necessary (Figure 5).

NOTE: OE separator plate part numbers are correct as of this printing. Sonnax recommends confirming part numbers with dealer as part supersession is common.

Figure 4

A. Early, 1st Design Plate

(OE 24246916)

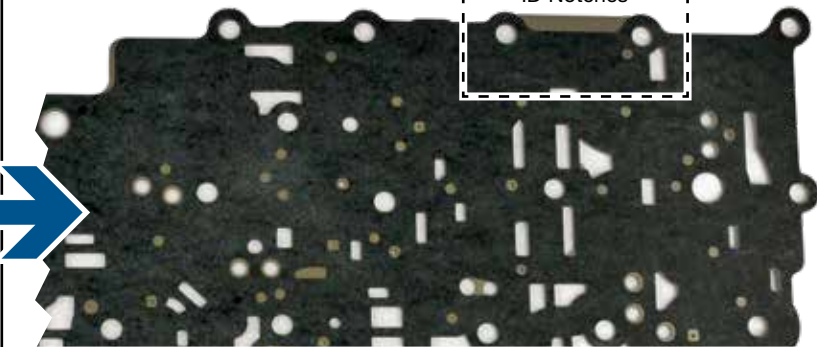

B. Early, 2nd Design Plate

(OE 24245720)

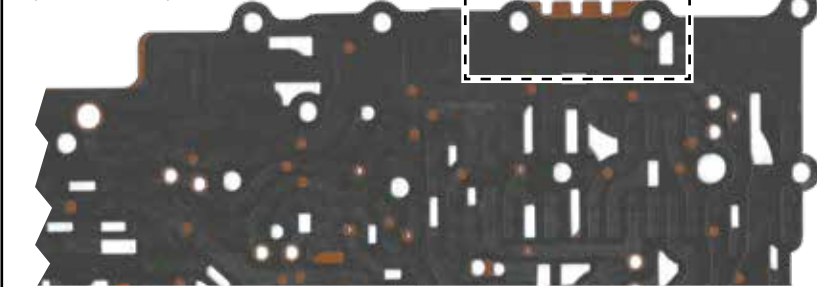

C. No #8 Checkball

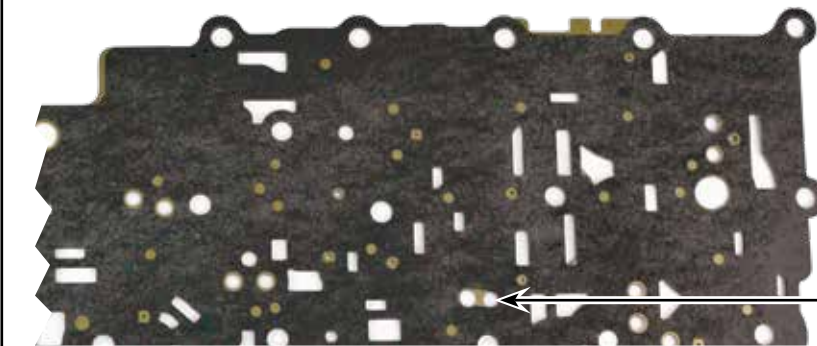

D. Requires #8 Checkball



Figure 5



GM 6L80, 6L90 SURE CURE KIT

PART NUMBER SC-6L80-6L90

INSTALLATION GUIDE

Parts are labeled here in order of installation. See other side of sheet for details on kit contents.

INSTALLATION DIAGRAM

CAUTION: This sheet is NOT intended to be a quick install guide. Not ALL steps/parts are shown here. See other side for details and use in conjunction with instruction booklet.

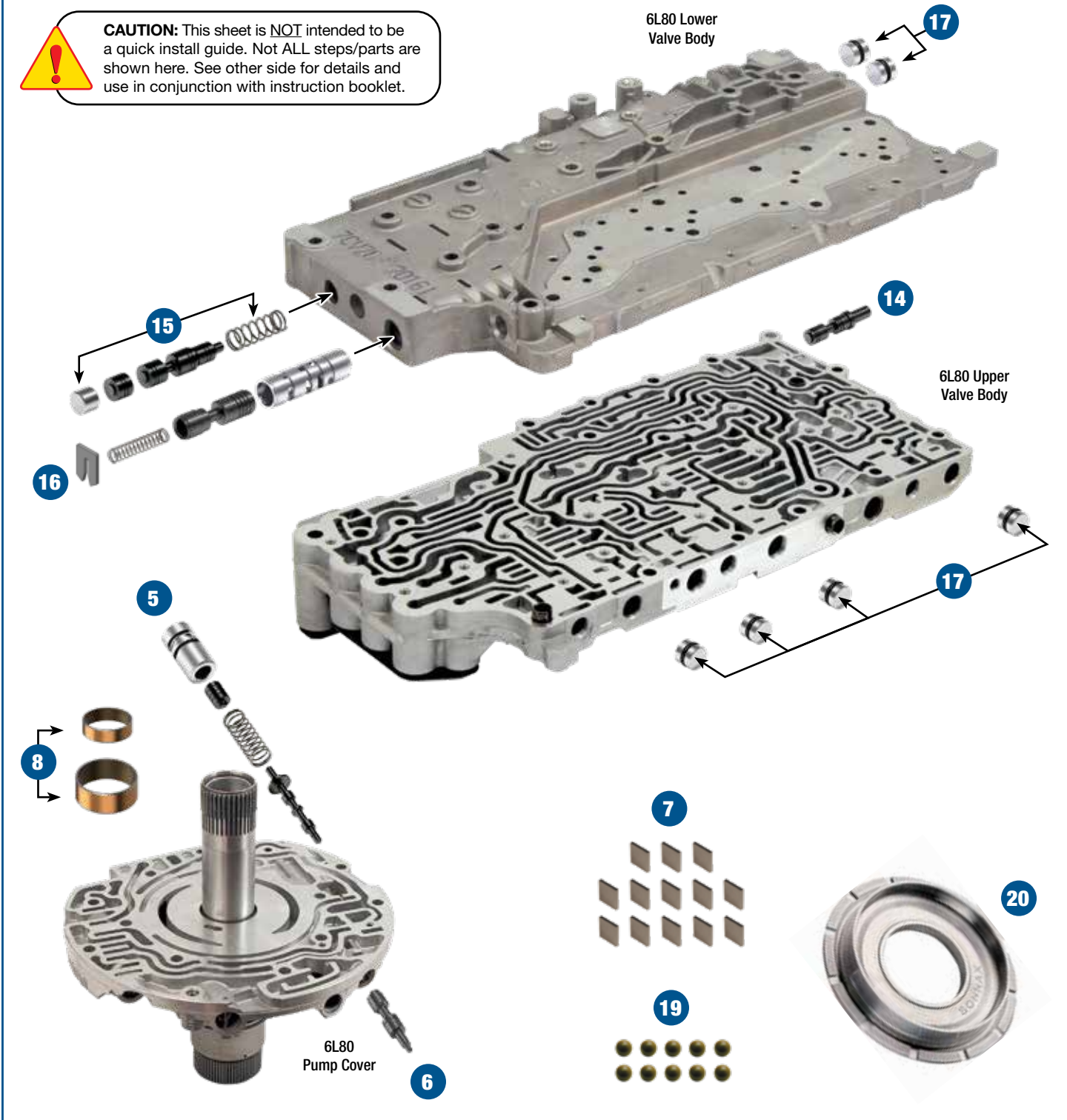

Kit Contents & Installation Steps See instruction booklet for details.

Step 1 Disassemble Pump

Step 2 Ream Pressure Regulator Bore

NOTE: Requires Sonnax tool kit F-104520-TL7C with VB-FIX alignment fixture and VB-06 oversized pump base plate, not included in this kit.

Step 3 Ream Converter Feed Limit Bore

NOTE: Requires Sonnax tool kit F-104520-TL11C with VB-FIX alignment fixture and VB-06 oversized pump base plate, not included in this kit.

Step 4 Drill Balance Port Bore

NOTE: Drill bit and items needed for locating bore placement provided in package pocket 2.

Step 5 Install Oversized Pressure Regulator & Boost Valve Kit

Packaging Pockets 1 & 2

- Pressure Regulator Valve • Boost Valve • Boost Sleeve
- Matching Outer Spring • Drill Bit .040"
- Checkballs 1/8" Dia., Alum. (2) 1 Extra

Step 6 Install Oversized Converter Feed Limit Valve

Packaging Pocket 2

- Valve

Step 7 Install Pump Vanes

Packaging Pocket 3

- Pump Vanes (13)

Step 8 Install Front & Rear Stator Bushings

Packaging Pocket 4

- Front Stator Bushing (Small) • Rear Stator Bushing (Large)

NOTE: Use of an arbor press is required for correct installation of bushings. Do not use a hydraulic press or a bushing driver/hammer combination to install, as doing so may distort the bushings and cause fitment issues.

Step 9 Pump Vacuum Test Verification

Step 10 Reassemble Pump

Step 11 Disassemble Valve Body

Step 12 Ream Actuator Feed Limit Bore

NOTE: Requires Sonnax tool kit F-104740-TL12 with VB-FIX alignment fixture, not included in this kit.

Step 13 Ream TCC Regulator Bore

NOTE: Requires Sonnax tool kit F-104740-TL7 with VB-FIX alignment fixture, not included in this kit.

Step 14 Install Oversized Actuator Feed Limit Valve

Packaging Pocket 5

- Valve

Step 15 Install Oversized TCC Regulator Valve Kit

Packaging Pocket 6

- TCC Regulator Valve • Shuttle Valve • End Plug • Spring

Step 16 Install Compensator Feed Regulator Valve Kit

Packaging Pocket 7

- Valve • Sleeve • Spring • Retaining Clip

Step 17 Install O-Ringed End Plugs

Packaging Pocket 8

- End Plugs (6) • O-Rings (9) 3 Extra

Step 18 Valve Body Vacuum Test Verifications

Step 19 Assemble Valve Body Sections & Checkballs

Packaging Pocket 9

- Checkballs, .250" dia., (10) 2 Extra

Step 20 Install HD 1-2-3-4 Piston

Technical Specifications	
Pump-to-Stator Bolts 15 ft-lb	Valve Body-to-Case Bolts 106 in-lb
Pump-to-Case Bolts 15 ft-lb	OE Endplay .034-.084"
Valve Body Assembly Bolts 35 in-lb	

NOTE: This Sure Cure fits GM 6L80 and 6L90 transmissions. Follow the identification guide to ensure you know which valve body you have.

PART INSTALLATION: To implement best practices and avoid chip contamination, wait until all valve body reaming operations are finished before installing Sonnax products. Detailed installation instructions steps are explained later in this booklet.

F-TOOL REAMING: Visit Sonnax web site www.sonnax.com for general F-Tool reaming instructions, best practices for bore preparation, cautions and suggestions on bore reaming.

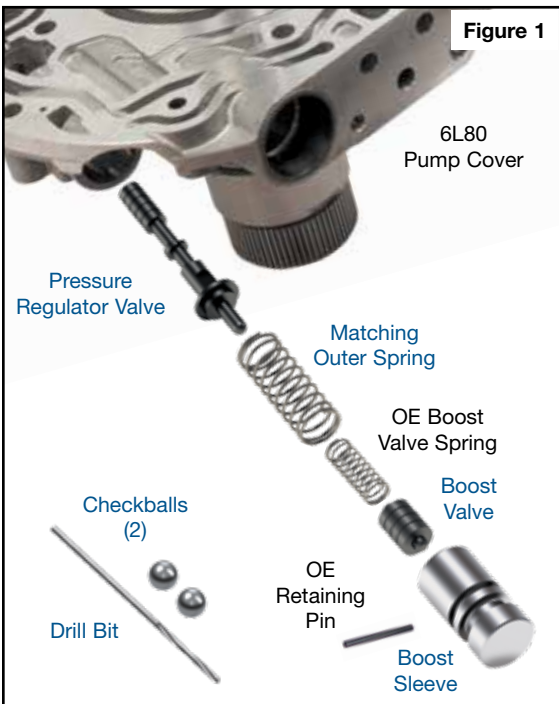

Step 1 Disassemble Pump

Step 2 Ream Pressure Regulator Bore

- Remove OE pressure regulator valve train from pump body bore (**Figure 1**).
- Save OE retaining pin and boost valve spring for reuse and discard remainder of the OE valve train.
- Align **VB-FIX** and **VB-06** to ream the pressure regulator bore using tool kit **F-104520-TL7C**.
- Ream the bore and clean thoroughly.

Step 3 Ream Converter Feed Limit Bore

- Remove OE retaining clip and spring, save both for reuse.
- Remove and discard OE converter limit valve.
- Align **VB-FIX** and **VB-06** to ream the converter feed limit bore using tool kit **F-104520-TL11C**.
- Ream the bore and clean thoroughly.

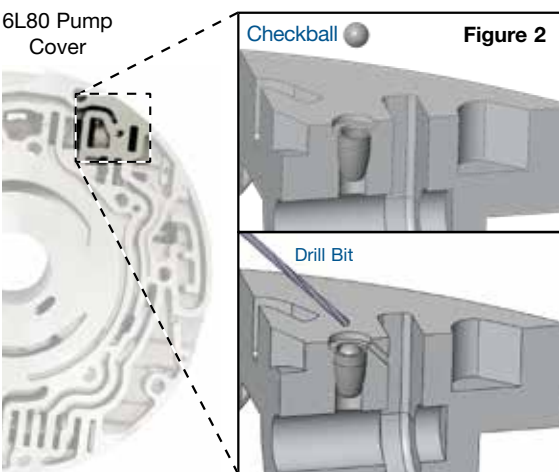

Step 4 Drill Balance Port Bore

- Locate OE balance feed orificed cup plug and adjacent inboard balance port for the pressure regulator valve.
- Drop one Sonnax 1/8" aluminum checkball into OE orificed cup plug. Drive checkball into cup plug with appropriately sized punch. Stake cup plug to prevent checkball displacement (**Figure 2**).
- Using included Sonnax drill bit, bore a new orifice from the cup plug bore to inboard balance port at an approximate 45° angle. Starting drill bit on counter-sunk surface of cup plug bore works best (**Figure 2**).

NOTE: Keep the drill bit length as short as possible (bury shank deep in the adapter). Be patient, it will take time to drill through the passage wall. Don't press the drill bit or it may break off. Drilling is necessary to prevent excessive line pressure. Watch a quick video to learn more and see drilling demonstrated by visiting this product page at www.sonnax.com (or scan QR Code).



Step 5 Install Oversized Pressure Regulator & Boost Valve

- Clean bore thoroughly, removing all debris and chips (Figure 1).
- Install Sonnax pressure regulator valve and Sonnax matching outer spring.
- Reinstall OE boost valve spring.
- Install Sonnax boost valve and sleeve, then reinstall OE retaining pin.

Step 6 Install Oversized Converter Feed Limit Valve

- Install Sonnax valve with the spring guide facing out as shown (Figure 3).
- Reinstall OE spring, ensuring the spring goes over the valve spring guide.
- Reinstall OE retaining clip.

Step 7 Install Pump Vanes

- Remove 13 OE pump vanes.
- Install 13 Sonnax pump vanes (Figure 4).

Step 8 Install Front and Rear Stator Bushings

- Remove OE front and rear stator bushings.
- Install Sonnax front and rear stator bushings.

NOTE: Use of an arbor press is required for correct installation of bushings. Do not use a hydraulic press or a bushing driver/hammer combination to install, as doing so may distort the bushings and cause fitment issues.

Step 9 Pump Vacuum Test Verification

- Vacuum test the pressure regulator and boost valve in the recommended testing ports. Vacuum should hold a minimum of 18 in-Hg (Figure 5).
- Vacuum test the converter feed limit valve in the recommended testing ports. Vacuum should hold a minimum of 20 in-Hg (Figure 6).

Step 10 Reassemble Pump

Step 11 Disassemble Valve Body

Step 12 Ream Actuator Feed Limit Bore

- Remove OE retainer and spring and save for reuse.
- Remove and discard OE valve.
- Align VB-FIX to ream the actuator feed limit valve bore using Sonnax tool kit F-104740-TL12.
- Ream the bore and clean thoroughly.

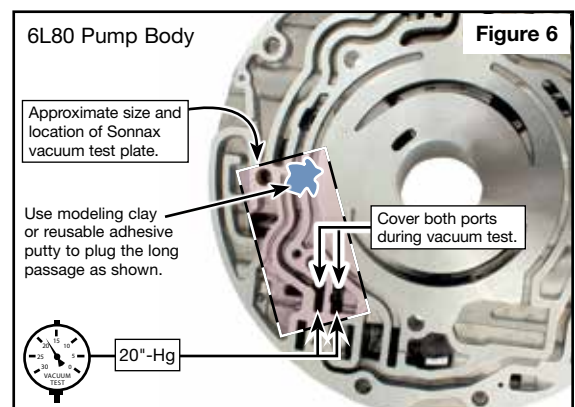
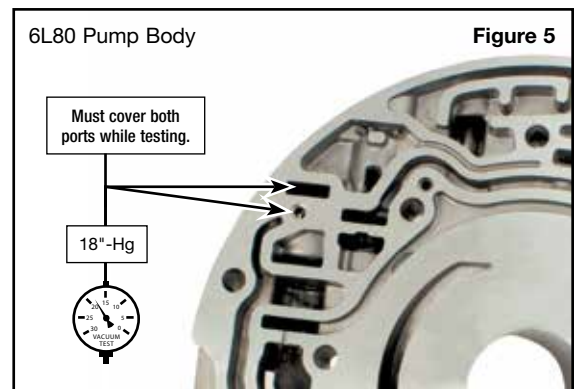
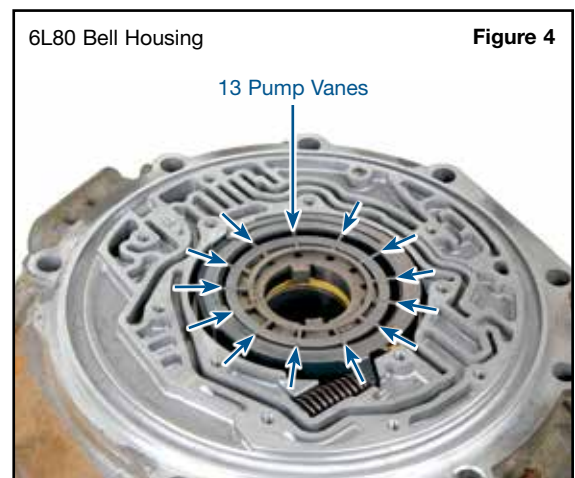
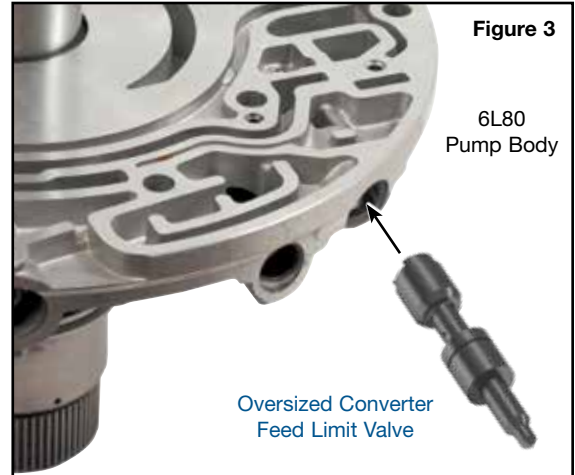

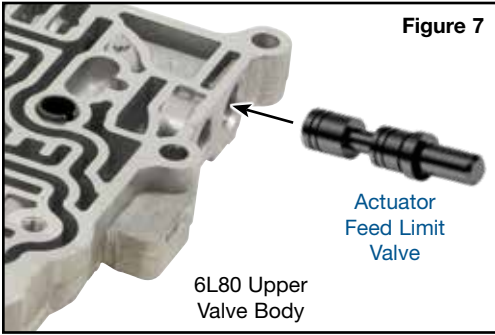

Step 13 Ream TCC Regulator Bore

- Remove OE retaining clip and save for reuse.
- Remove and discard OE end plug, shuttle valve, TCC regulator valve and spring.
- Align **VB-FIX** to ream the TCC regulator valve bore using Sonnax tool kit **F-104740-TL7**.
- Ream the bore and clean thoroughly.

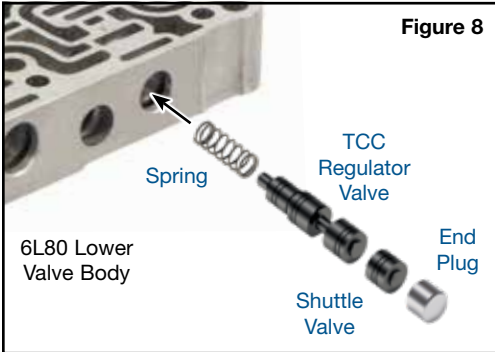

Step 14 Install Oversized Actuator Feed Limit Valve

- Install Sonnax valve, spring stem outward as shown (**Figure 7**).
- Reinstall OE spring and retainer.

Step 15 Install Oversized TCC Regulator Valve Kit

- Ensure all debris has been removed from the valve bore and valve body.
- Install Sonnax spring, followed by Sonnax valve (spring guide first), ensuring spring goes over the spring guide (**Figure 8**).
- Install Sonnax shuttle valve and end plug.
- Reinstall OE retaining clip.

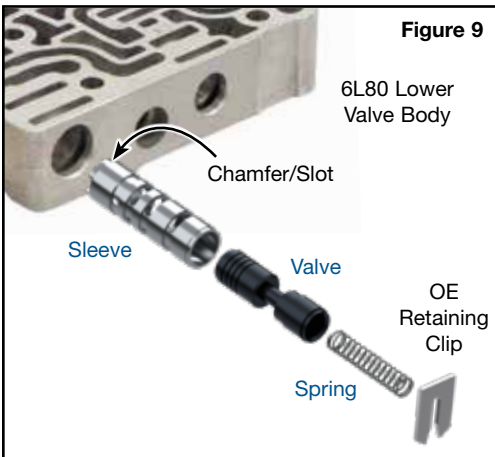

Step 16 Install Compensator Feed Regulator Valve Kit

- Remove OE retaining clip and save for reuse.
- Remove and discard OE spring and valve.
- Install Sonnax valve and sleeve, ensuring chamfer/slot end faces inboard (**Figure 9**).
- Install Sonnax spring and reinstall OE retaining clip.

NOTE: Due to slight casting inconsistencies between applications, the retaining clip may not install easily. If there is significant resistance, remove the sleeve and flat sand the outboard face slightly.

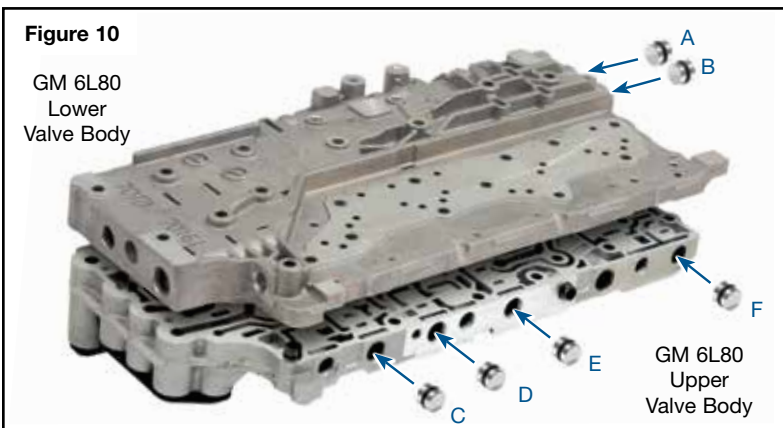

Step 17 Install O-Ringed End Plugs

- Remove OE plug retainers and keep for reuse.
- Remove and discard OE end plugs.
- Install Sonnax O-rings in shallow grooves on Sonnax end plugs. Then lubricate with Sonnax Slippery Stick **O-LUBE** and roll on bench to size the O-rings in the grooves.
- Carefully insert Sonnax O-ringed end plugs into the bores just far enough to reinstall the OE retainer (**Figure 10**).

NOTE: A small, flat-bladed screwdriver inserted through the retainer port cavity may be used to help compress the O-ring into the bore.

Lower Valve Body		Upper Valve Body	
A	Clutch Select Valve No. 3 Bore	C	1-2-3-4 Clutch Regulator Valve Bore
B	Clutch Select Valve No. 2 Bore	D	3-5 Reverse Clutch Regulator Valve Bore
		E	2-6 Clutch Regulator Valve Bore
		F	CBR1/C456 Clutch Regulator Valve Bore

Step 18 Valve Body Vacuum Test Verifications

- Vacuum test the actuator feed limit valve in the recommended testing ports. Vacuum should hold a minimum of 16 in-Hg (Figure 11).
- Vacuum test the TCC regulator valve in the recommended testing ports. Vacuum should hold a minimum of 13.5 in-Hg and 18 in-Hg (Figure 12).
- Vacuum test the compensator feed regulator valve in the recommended testing ports. Vacuum should hold a minimum of 18 in-Hg (Figure 13).
- Vacuum tests at the ports indicated should hold the recommended minimum of 18 in-Hg (Figure 14 & 15).

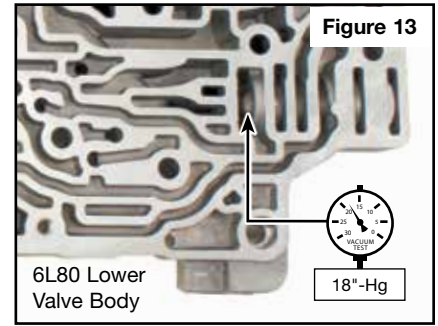
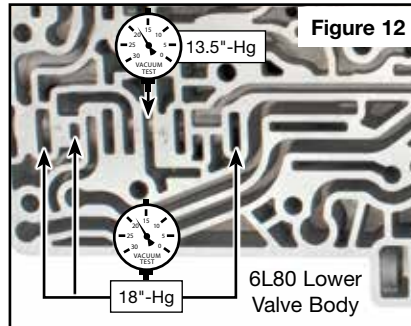

Step 19 Assemble Valve Body Sections

- Remove existing 8 checkballs from valve body.
- Install 8 Sonnax checkballs in same locations (Figure 14).

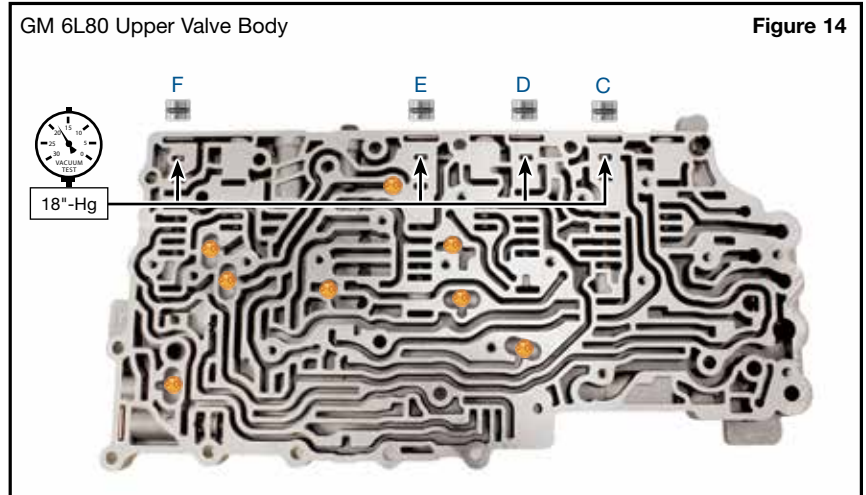

Step 20 Install Heavy Duty 1-2-3-4 Piston

- Remove existing 1-2-3-4 piston.
- Install Sonnax heavy duty 1-2-3-4 piston.

