

Heavy Duty Input Shaft

Part No.

77733-11SB

For units with 300mm converter,
non-reluctor style shaft.

GM 4L60-E, 4L65-E, 4L70-E

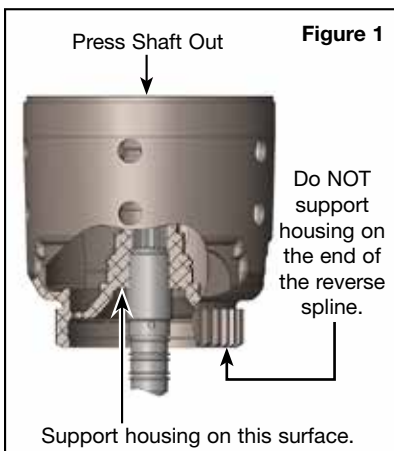

1. Disassembly

- Set the input drum into a suitable press. Support the aluminum housing as indicated in (Figure 1) using an appropriate sized tube or a spare (not to be reused) 4L60 stator shaft and selective spacer (with bearing left out).

CAUTION: NOT supporting the drum as indicated can result in damage to the housing.

- Press the OE input shaft out of the housing.

2. Installation & Assembly

CAUTION: If using an input drum reinforcement sleeve, the shaft must be installed before the reinforcement sleeve.

- Apply Loctite® sleeve retainer to splines and bore of housing and splines and outer diameter of shaft.
- Support housing at location indicated (Figure 2).

CAUTION: NOT supporting the housing as indicated can result in damage to the housing.

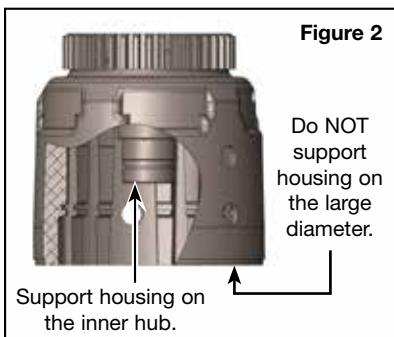

- Line up the splines in the housing with splines on the shaft. Using a suitable press, install the shaft until seated. Do NOT hammer or pound the shaft into place.
- Verify input shaft is installed all the way by looking through the housing at the location shown in the figure (Figure 3) shaft installation check. The oil passage within the shaft should be visible through the housing.
- Blow compressed air through all passages to remove excess Loctite.

