

Oversized Cooler/Lube Flow Control Valve Kit

Part No.

168740-08K



- Valve
- Spring
- End Plug

Tool Kit

Part No.

F-168740-TL8



- Reamer
- Reamer Jig
- Guide Pin

NOTE: Sonnax “F-Tool” kits designed to service a specific bore require the VB-FIX, a self-aligning valve body reaming fixture. More information and instructions can be found online at www.sonnax.com.

Toyota/Lexus UA80E, UA80F, UB80E, UB80F

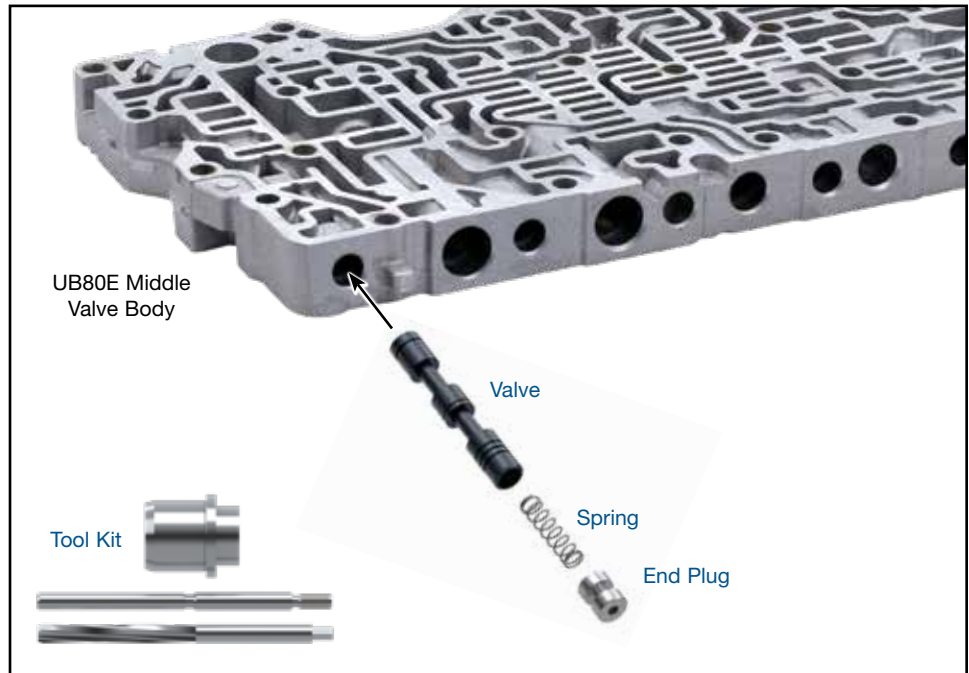

1. Disassembly

- Remove OE retaining clip and save for reuse.
- Remove and discard OE end plug, spring and valve.

2. Bore Reaming

Ream the cooler/lube flow control valve bore (for reaming instructions/reamer care, please visit www.sonnax.com). Sonnax reaming tool kit F-168740-TL8 and VB-FIX are required for this operation.

3. Installation & Assembly

- Be certain all debris has been removed from the valve bore and valve body.
- Install Sonnax valve and spring.
- Insert Sonnax end plug into the bore just far enough to reinstall the OE retaining clip.
- Reinstall OE retaining clip.

4. Final Testing

Vacuum testing at the port(s) indicated holds the recommended minimum 18 in-Hg.

