

## Ford 10R60, 10R80, 10R90, 10R140; GM 10L80/90 (Gen. 1)

### LPC Signal Damper Piston Kit

**Part No.**  
**105740-04K**

- Piston
- Sleeve
- Spring
- O-Rings (2) 1 Extra

Patent No. 11,933,326

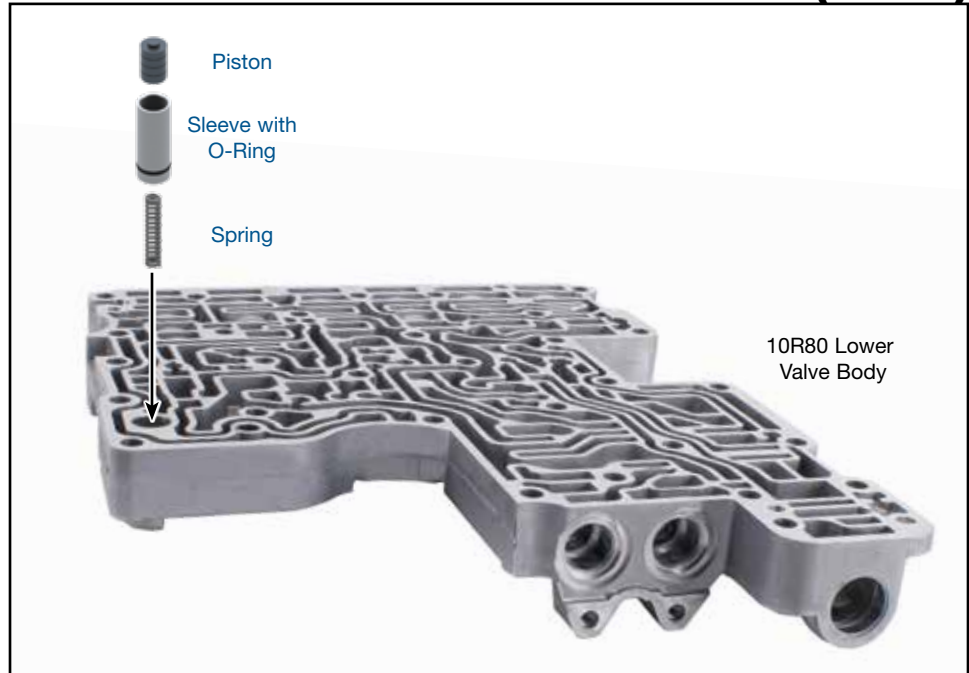

### 1. Disassembly

Remove and discard the OE damper piston and spring.

### 2. Installation & Assembly

- a. Be certain all debris has been removed from the valve bore and valve body.
- b. Install O-ring into groove of Sonnax sleeve. Lubricate O-ringed sleeve with Sonnax Slippery Stick **O-LUBE**. Roll on bench to size O-ring into groove.
- c. Install Sonnax spring into Sonnax piston/sleeve assembly through the bottom hole.
- d. Install the Sonnax assembly and Sonnax spring into the bore.

### 3. Final Testing

Vacuum testing at their port(s) indicated holds the recommended minimum 18 in.-Hg.

