

## Oversized Lubrication Valve Kit



**Part No.**  
**823740-03K**

- Valve
- Spring
- End Plug
- O-Rings (2) 1 Extra

## Tool Kit



**Part No.**  
**F-823740-TL3**

- Reamer
- Reamer Jig
- Guide Pin

**NOTE:** Sonnax “F-Tool” kits designed to service a specific bore require the VB-FIX, a self-aligning valve body reaming fixture. More information and instructions can be found online at [www.sonnax.com](http://www.sonnax.com).

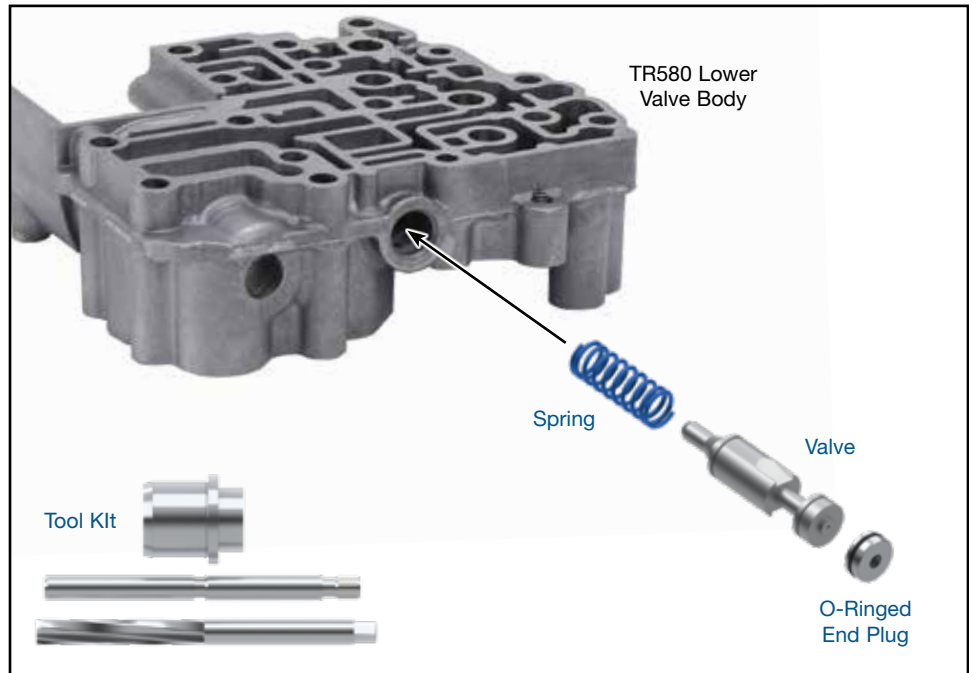

### 1. Disassembly

- Remove OE retaining clip and save for reuse.
- Remove and discard the OE end plug, valve and spring.

### 2. Bore Reaming

Ream the lubrication valve bore (for reaming instructions/reamer care, please visit [www.sonnax.com](http://www.sonnax.com)). Sonnax reaming tool kit **F-823740-TL3** and **VB-FIX** are required for this operation.

### 3. Installation & Assembly

- Be certain all debris has been removed from the valve bore and valve body.
- Install Sonnax spring, followed by the Sonnax valve.
- Install Sonnax O-ring into the shallow groove on the Sonnax end plug. Then lubricate with Sonnax Slippery Stick **O-LUBE** and roll on bench to size the O-ring into the groove.

- Install O-ringed end plug into the bore and secure with OE retaining clip.

### 4. Final Testing

Vacuum testing at the port(s) indicated holds the recommended minimum 18 in-Hg.

