

FORD 10R60, 10R80, 10R90; GM 10L60/80/90 (Gen. 1) ZIP KIT®

PART NUMBER 10L80-G1-10R80-ZIP

QUICK GUIDE

Parts are labeled here in order of installation. See other side of sheet for details on kit contents.

INSTALLATION DIAGRAM

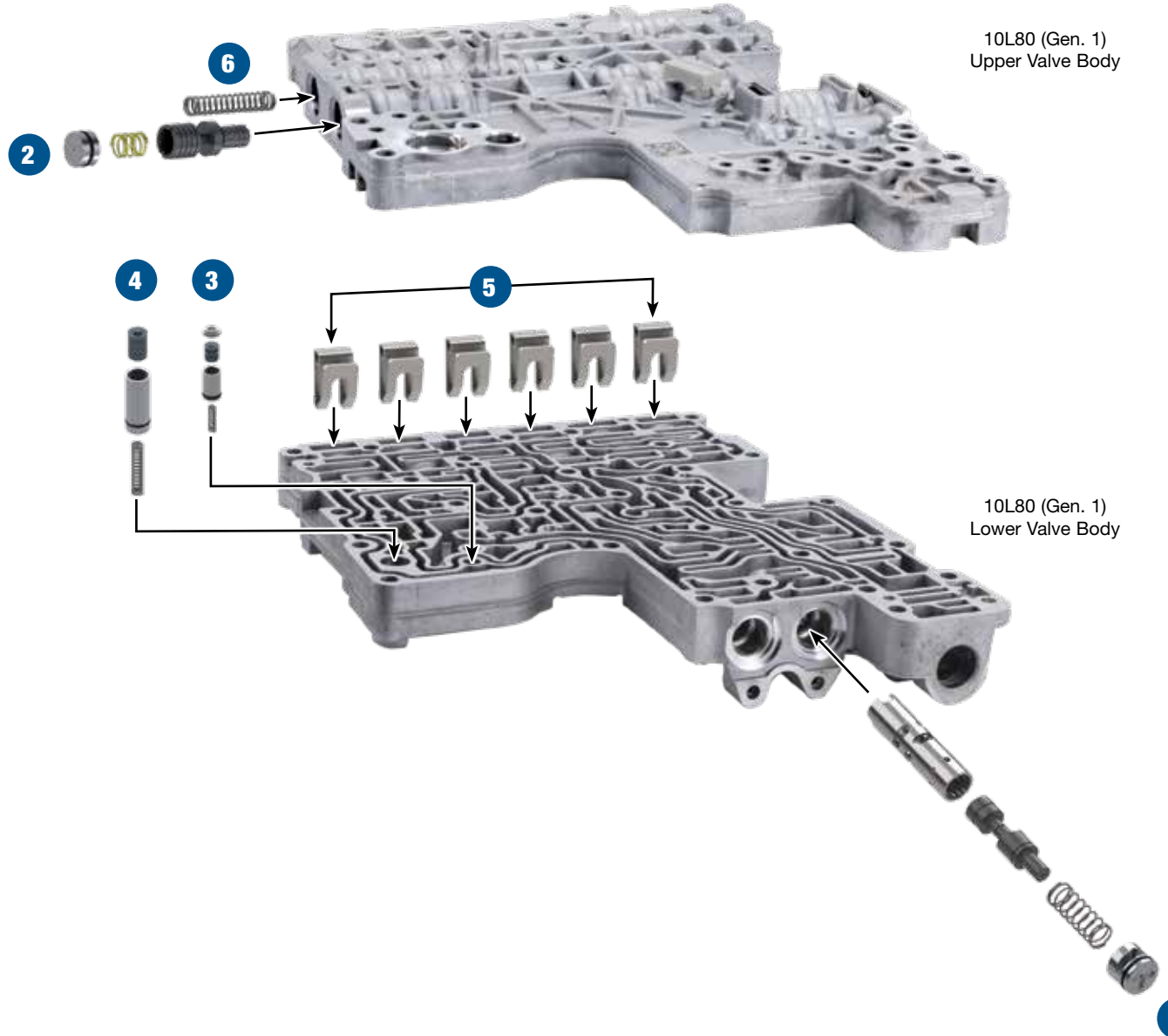

In addition to general rebuilding tips and technical information, the technical booklet included in this kit contains vacuum testing and additional repair options for higher mileage units or for repairing specific complaints which are beyond the scope of this kit.

Kit Contents & Installation Steps

Step 1 Replace TCC Priority Valve

Place O-ring in groove on end plug. Lubricate with Sonnax Slippery Stick **O-LUBE** and roll to size on bench. Install end plug with O-ring outboard.

Packaging Pocket #1

- Sleeve
- Valve
- Spring
- End Plug*
- O-Rings (2) 1 Extra



*NOTE: End plug has specific orientation for installation. See page 2 in installation booklet for details.

Step 2 Replace Main Pressure Regulator Valve

Place O-ring in groove on end plug. Lubricate with Sonnax Slippery Stick **O-LUBE** and roll to size on bench. Install end plug with O-ring outboard.

Packaging Pocket #2

- Valve
- End Plug
- O-Rings (2) 1 Extra
- Spring

Step 3 Replace TCC Signal Damper Piston

Packaging Pocket #3

- Plug
- Piston
- Sleeve
- Spring
- O-Rings (2) 1 Extra

Step 4 Replace LPC Signal Damper Piston

Packaging Pocket #4

- Piston
- Sleeve
- Spring
- O-Rings (2) 1 Extra

Step 5 Insert Solenoid Stabilization Retainers

Packaging Pocket #5

Retainers (6)

Step 6 Replace TCC Regulator Valve Spring

Packaging Pocket #6

Spring

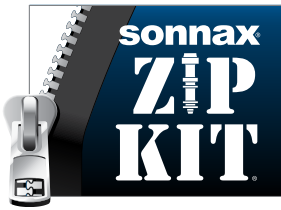

FORD 10R60, 10R80, 10R90; GM 10L60/80/90 (Gen. 1) ZIP KIT®

PART NUMBER 10L80-G1-10R80-ZIP

INSTALLATION & TESTING BOOKLET

Zip Kit Instructions

1. Valve Body Disassembly

- Ensure you have the correct valve body for this kit (Figure 1).
- Disconnect the wiring harness from the nine solenoid connection ports.
- Remove bolts 1, 2 and 3 from the wire harness mount (Figure 2). Then, remove the wiring harness and the TFT sensor on the back.
- Remove the remaining 17 bolts from the main valve body (Figure 2) and separate the upper and lower valve bodies.
- Remove the two bolts from the EPC and TCC solenoids (Figure 3).
- Remove the two bolts from the separator plate (Figure 4). Be aware of accumulators below the separator plate.

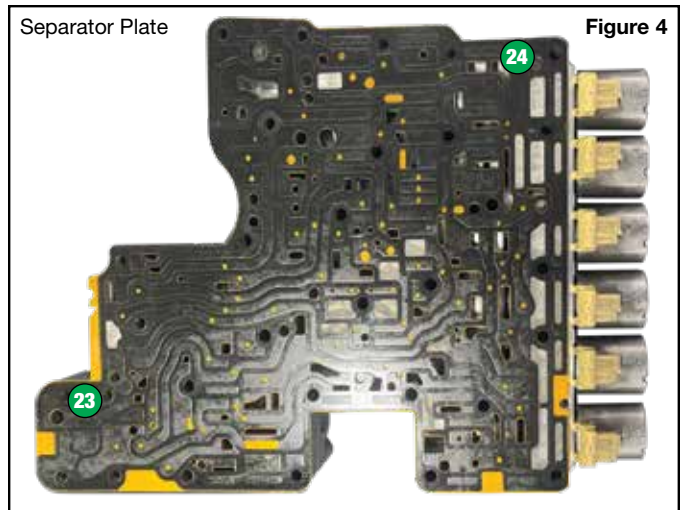
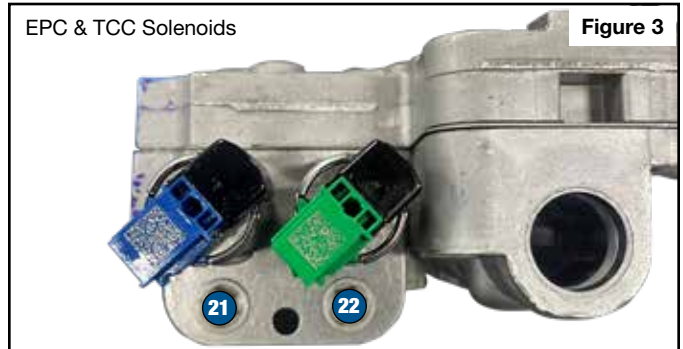
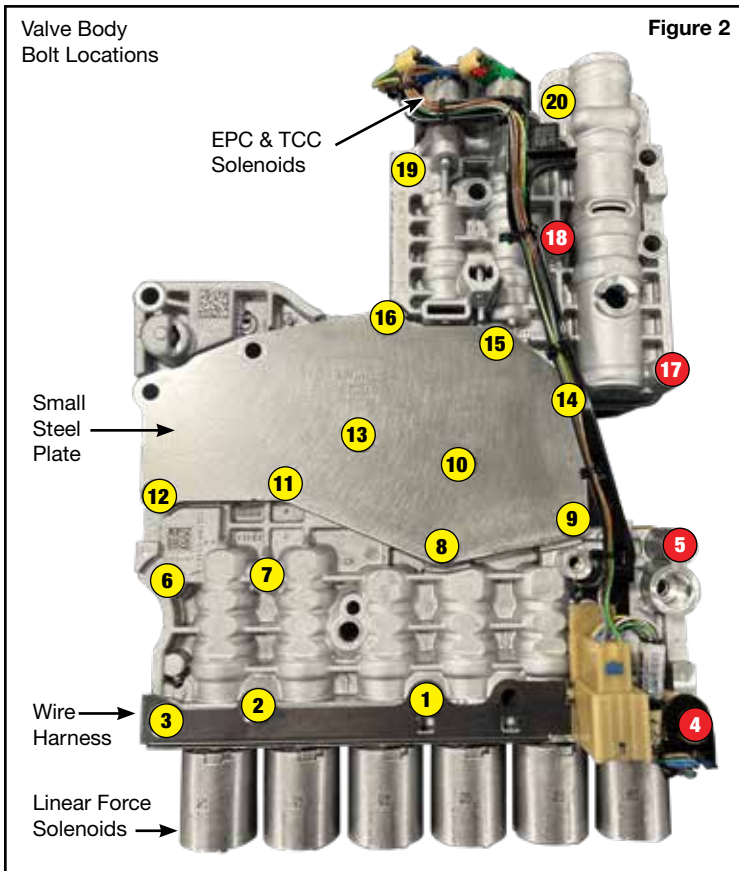
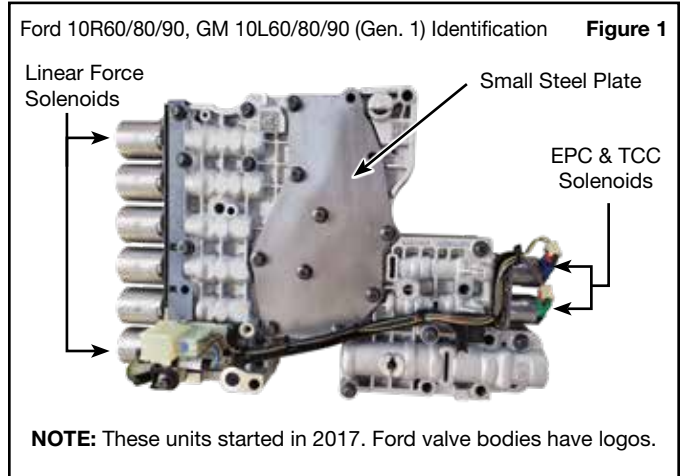

Bolt Color	Bolt Length	Bolt Type	Torque Specification
Yellow	48.5mm	Torx® Plus M6X1.0	12 Nm (106 in-lb)
Red	68.5mm	8mm Head M6X1.0	12 Nm (106 in-lb)
Blue	23mm	8mm Head M6X1.0	9 Nm (80 in-lb)
Green	19mm	Torx® M6X1.0	8 Nm (71 in-lb)

2. Replace TCC Priority Valve

- a. Remove OE retaining clip and set aside for reuse.
- b. Remove and discard OE end plug, spring and valve.
- c. Be certain all debris has been removed from the valve bore and valve body.
- d. Install Sonnax sleeve and valve followed by Sonnax spring (**Figure 5**).
- e. Install Sonnax O-ring into shallow groove of Sonnax end plug. Lubricate with Sonnax Slippery Stick **O-LUBE** and roll on bench to size the O-ring into the groove (**Figure 5**).
- f. Carefully insert Sonnax O-ringed end plug into the bore just far enough to reinstall the OE retainer. Use a flat-head screwdriver to rotate the end plug so the T-groove resembles an upright capital “T” (**Figure 6**).
- g. Once the end plug is in the correct orientation, align the end plug to the valve body slot/hole and reinstall the corresponding OE retaining pin.

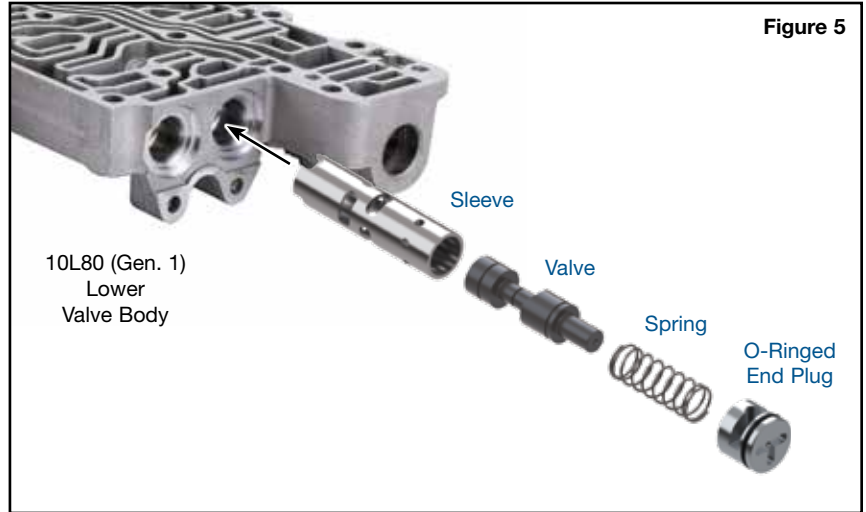

Figure 5

3. Replace Main Pressure Regulator Valve (**Figure 7**)

- a. Remove and set aside OE retaining clip for reuse.
- b. Remove and discard OE end plug, large diameter spring and valve.
- c. Set aside OE small diameter spring for reuse.
- d. Ensure all debris has been removed from valve bore and valve body.
- e. Reinstall OE small diameter spring.
- f. Place Sonnax spring into the pocket of Sonnax valve and install the set into the valve bore.
- g. Install Sonnax O-ring into shallow groove of Sonnax end plug. Lubricate with Sonnax Slippery Stick **O-LUBE** and roll on bench to size O-ring into the groove.
- h. Carefully insert Sonnax O-ringed end plug into the bore and reinstall the OE retaining clip.

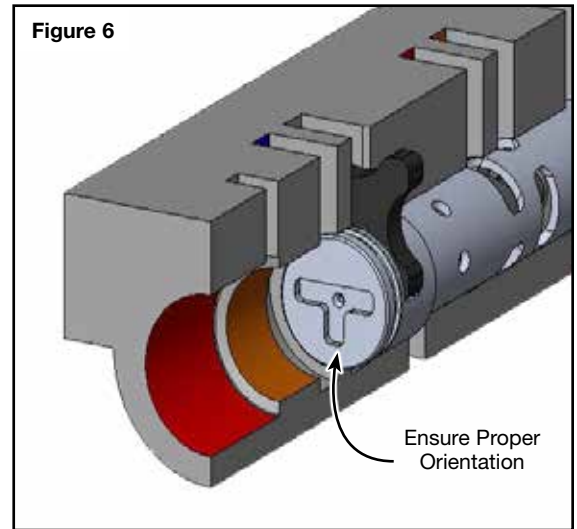

Figure 6

4. Replace TCC Signal Damper Piston (**Figure 8**)

- a. Remove and discard the OE piston and spring.
- b. Be certain all debris has been removed from valve bore and valve body.
- c. Install O-ring into groove of Sonnax sleeve. Lubricate O-ringed sleeve with Sonnax Slippery Stick **O-LUBE**. Roll on bench to size O-ring into groove.
- d. Install Sonnax spring into the Sonnax piston/sleeve assembly through the bottom hole.
- e. Install Sonnax piston/sleeve assembly and spring into the bore.
- f. Install the plug on top of the piston/sleeve assembly so the smaller end is facing up. This smaller end is meant to go through the hole in the separator plate.

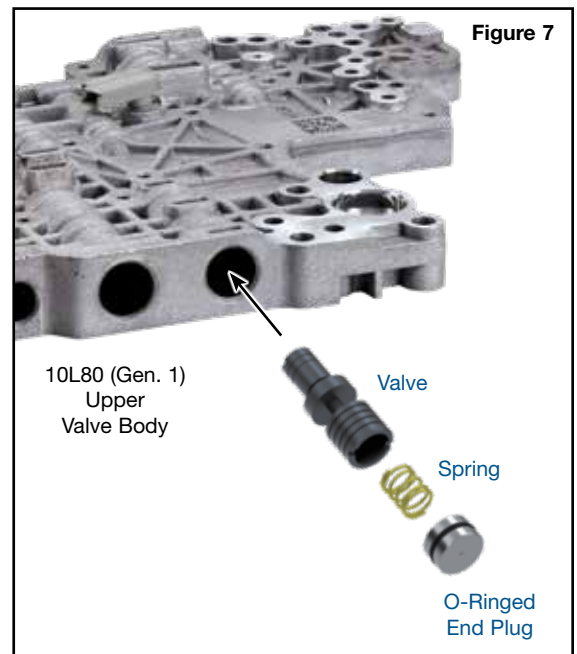

Figure 7

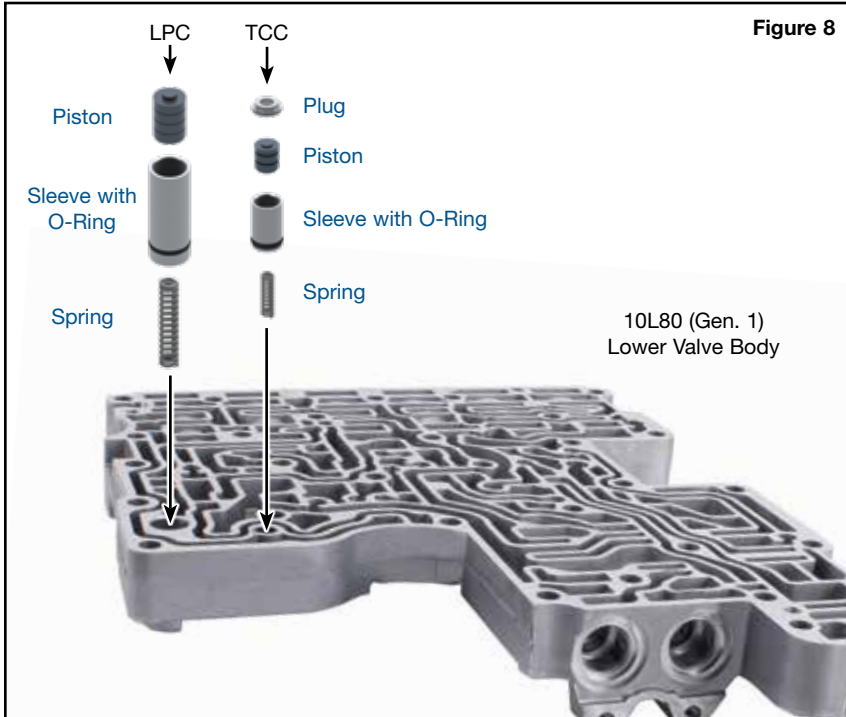

Figure 8

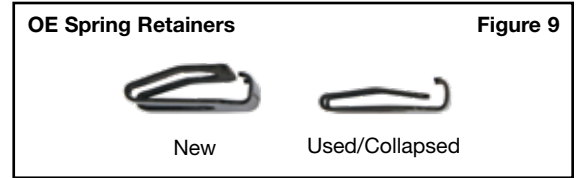

Figure 9

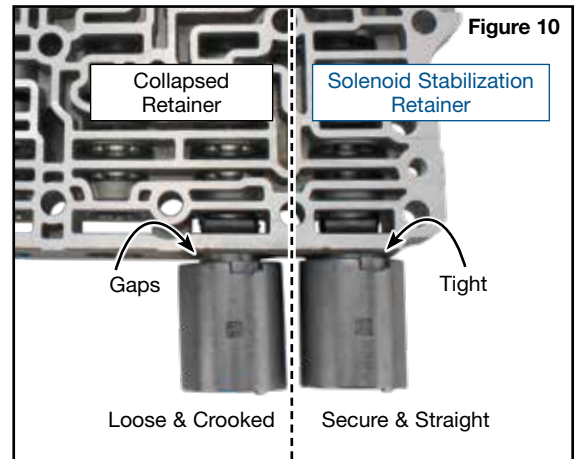

Figure 10

5. Replace LPC Signal Damper (Figure 8)

- Remove and discard the OE damper piston and spring.
- Be certain all debris has been removed from the valve bore and valve body.
- Install O-ring into groove of Sonnax sleeve. Lubricate O-ringed sleeve with Sonnax Slippery Stick **O-LUBE**. Roll on bench to size O-ring into groove.
- Install Sonnax spring into Sonnax piston/sleeve assembly through the bottom hole.
- Install the Sonnax assembly and Sonnax spring into the bore.

6. Replace OE Solenoid Retainer Clips

- Remove and discard older/collapsed OE retainers (**Figure 9**). Be sure to hold the shift solenoid to prevent it from falling.
- Reinstall the solenoid into the bore and hold it in place.
- Install Sonnax solenoid stabilization retainer into the gap around the shift solenoid shaft (**Figure 10**). The direction of the clip should be as shown (**Figure 11**). The long flat surface should be contacting the valve body wall inside the gap.

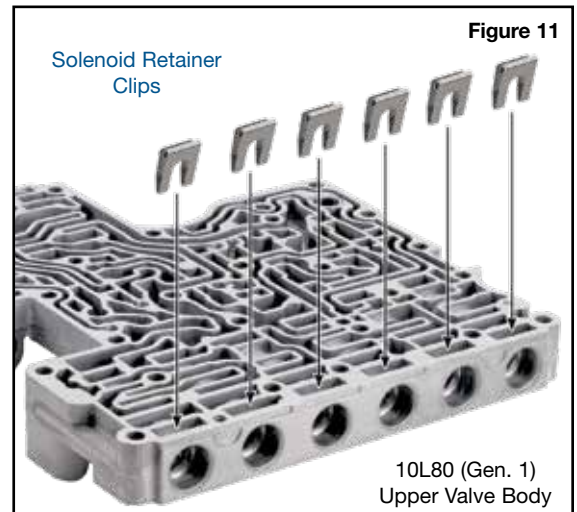

Figure 11

7. Replace TCC Regulator Valve Spring

- Remove and save OE retainer, as well as OE valve/sleeve assembly.
- Remove and discard OE spring.
- Be certain all debris has been removed from the valve bore and valve body.
- Install Sonnax spring (**Figure 12**).
- Reinstall OE valve/sleeve assembly and the retaining clip.
- Once installed, the end of the valve should be flush with the end of the sleeve. Pressing on the end of this valve should give resistance but move smoothly in the sleeve.

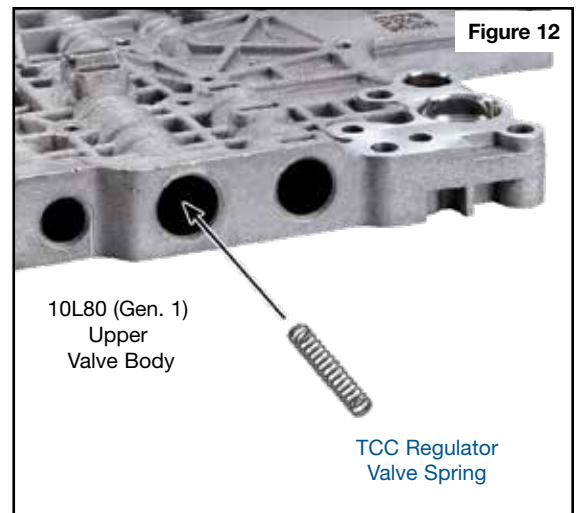

Figure 12

Critical Wear Areas & Vacuum Test Locations



NOTE: OE valves are shown in rest position and should be tested in rest position unless otherwise indicated. Test locations are pointed to with an arrow. Springs are not shown for visual clarity. Low vacuum reading indicates wear and Sonnax parts are noted for replacement.

Lower Valve Body • 10R80 Shown

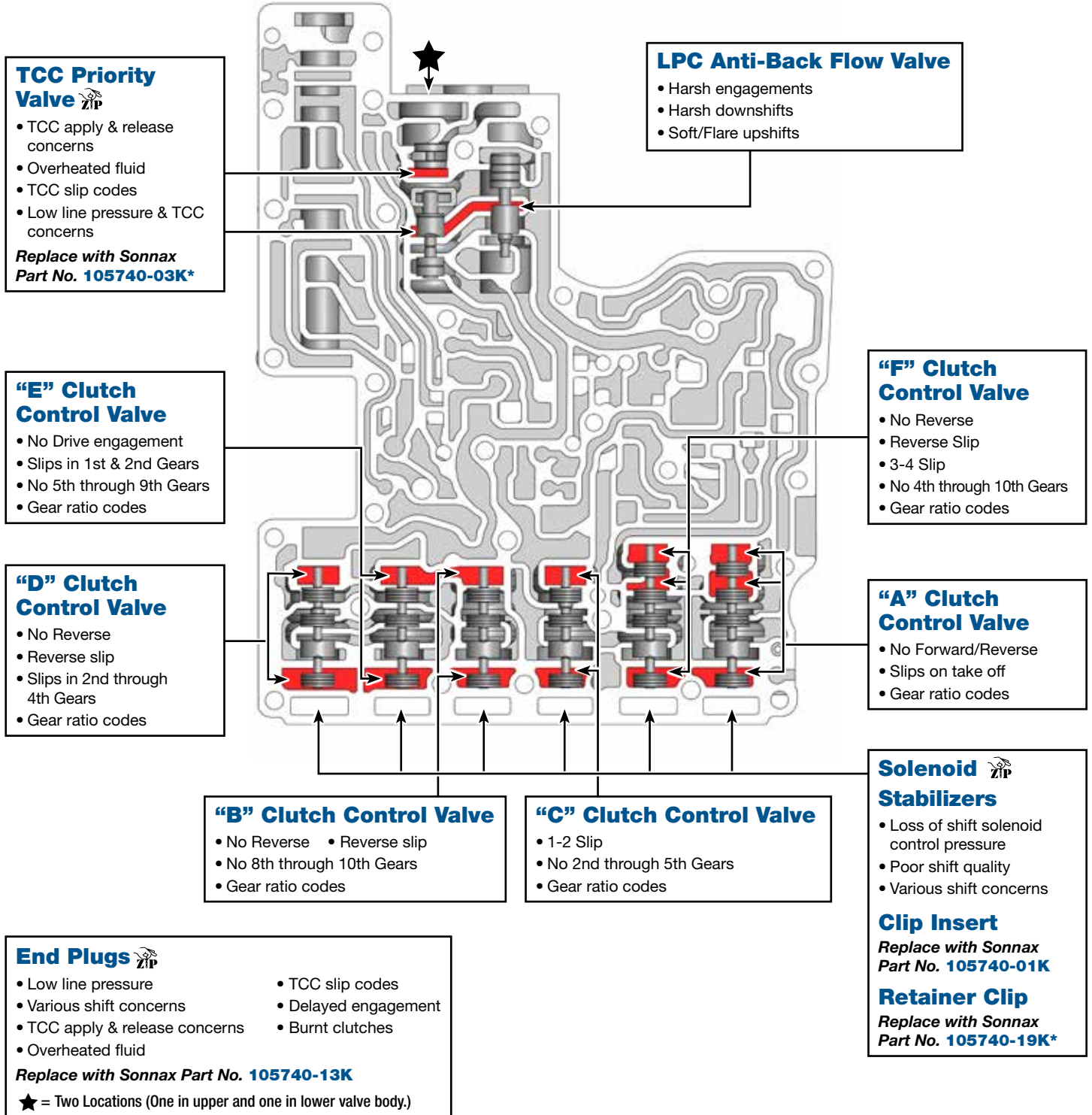

* Part numbers with an asterisk (*) are included in this Zip Kit. Other part numbers are available separately.

Critical Wear Areas & Vacuum Test Locations



NOTE: OE valves are shown in rest position and should be tested in rest position unless otherwise indicated. Test locations are pointed to with an arrow. Springs are not shown for visual clarity. Low vacuum reading indicates wear and Sonnax parts are noted for replacement.

Upper Valve Body • 10R80 Shown

“F” Clutch Latch

- Delayed/Harsh Reverse
- No 4th through 10th Gears
- Gear ratio codes

“A” Clutch Latch

- No Forward/Reverse
- Harsh engagements
- Gear ratio codes

Clutch Gain Control Valve

- 4/5 Harsh/Flare
- Harsh 6th to 4th gear downshifts/passing gear
- Passing gear flare back to 4th

TCC Regulator Valve

- TCC apply & release concerns
- Low TCC apply pressure in full lockup
- Converter shudder & TCC slip

Replace with Sonnax Part Nos.
105740-15K Fits Ford 10R60/80/90
 or
105740-16K Fits GM 10L60/80/90 (Gen. 1)
 or
105740-17K Fits GM 10L60/80/90 (Gen. 2)
 All Require **F-105740-TL16 & VB-FIX**

“B” Clutch Latch

- Poor Reverse engagement
- No 8th through 10th Gears
- Gear ratio codes

“C” Clutch Latch

- 1-2 Slip
- No 2nd through 5th Gears
- Gear ratio codes

Bypass Valve

- Overheated fluid
- Lube failure
- Low cooler flow
- Overheating
- Low pressure-to-balance pistons

Main Pressure Regulator Valve

- Low line pressure
- Various shift concerns
- Delayed engagement
- Poor shift quality
- Burnt clutches
- TCC apply & release concerns

Replace with Sonnax Part Nos.
105740-12K* or 105740-20K Requires **F-105740-TL20 & VB-FIX**

Lube Control Valve

- Overheated fluid
- Lube failure
- Low cooler flow
- Overheating
- Low pressure-to-balance pistons

LPC Signal Damper Piston

- Harsh shifts
- High line pressure

Replace with Sonnax Part No. 105740-04K*

NOTE: Keep hole on backside of valve body uncovered while testing.

TCC Signal Damper Piston

- Lube failures
- TCC apply & release concerns
- Overheated fluid
- Overheated converter
- Delayed engagement

Replace with Sonnax Part No. 105740-06K*

NOTE: Keep hole on backside of valve body uncovered while testing.

End Plugs

- Low line pressure
- Various shift concerns
- TCC apply & release concerns
- Overheated fluid
- TCC slip codes
- Delayed engagement
- Burnt clutches

Replace with Sonnax Part No. 105740-13K

★ = Two Locations (One in upper and one in lower valve body.)

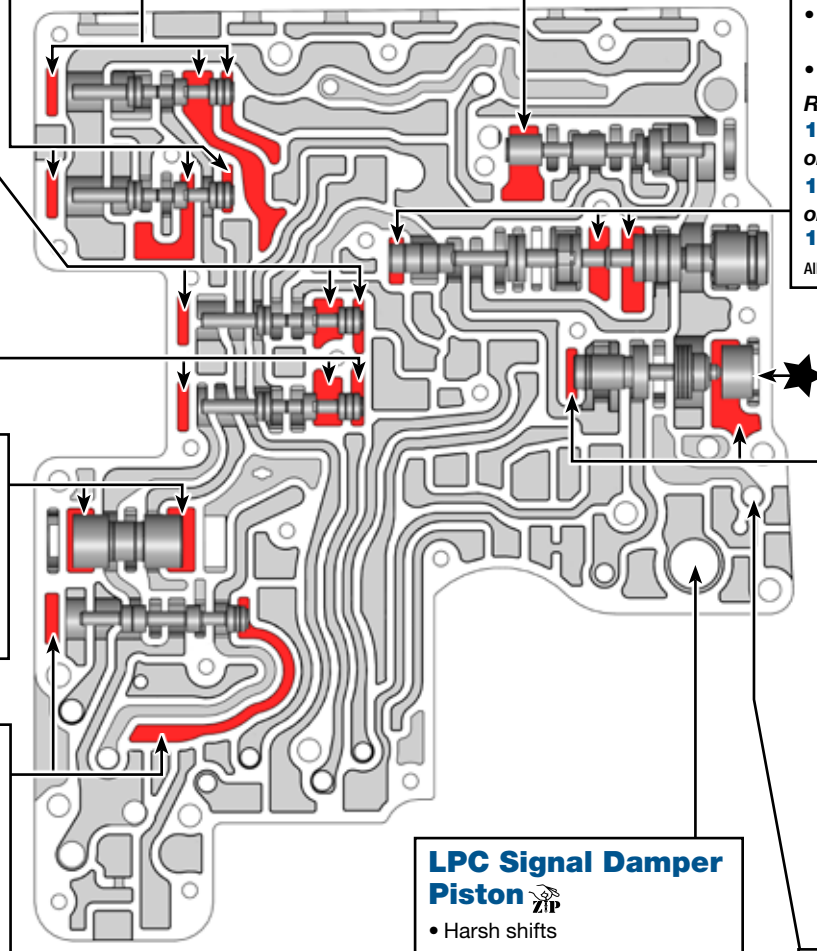

* Part numbers with an asterisk (*) are included in this Zip Kit. Other part numbers are available separately.

OE Exploded View

Lower Valve Body • 10L80 (Gen. 1) Shown

NOTE: Depending upon vehicle application, the OE springs shown may not be present.

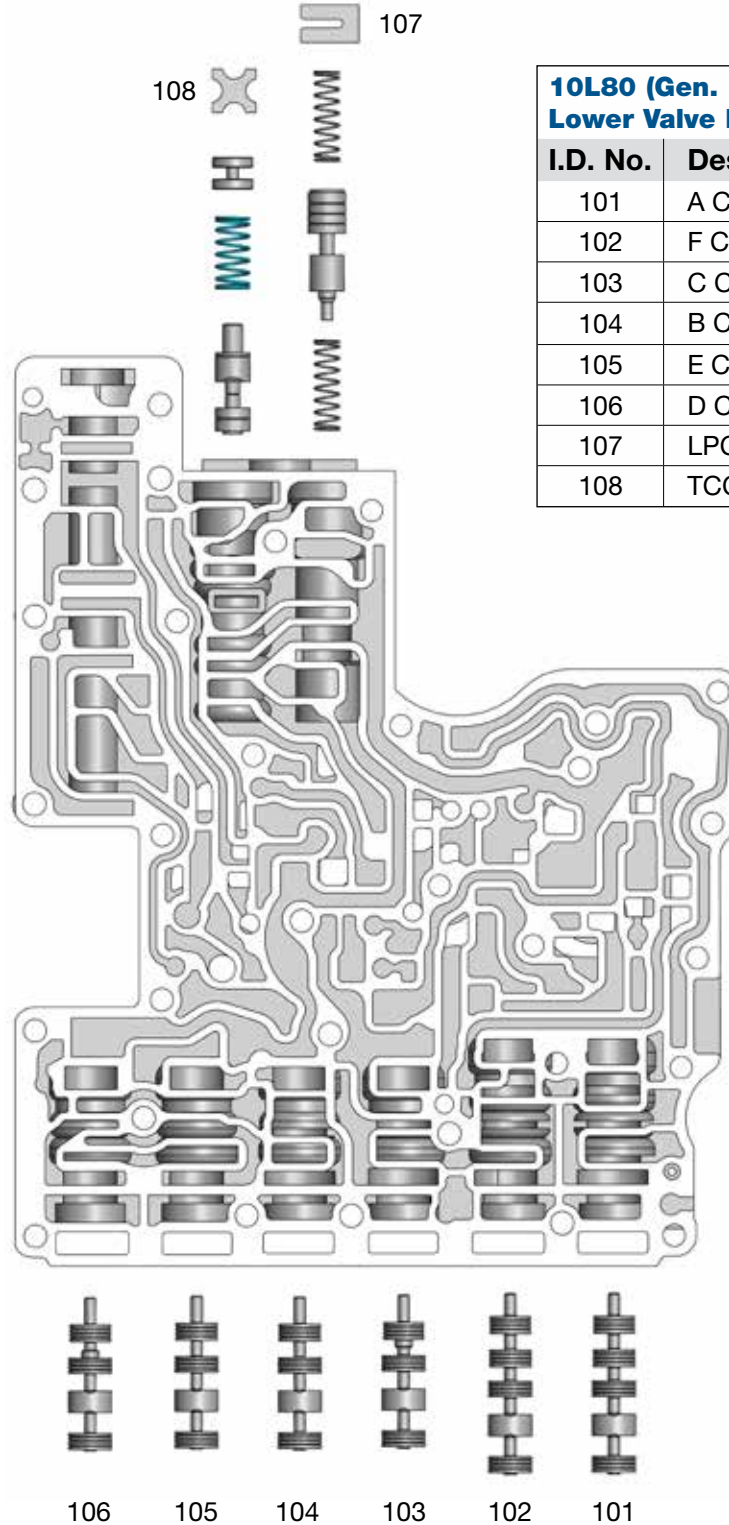

10L80 (Gen. 1) Lower Valve Body Descriptions	
I.D. No.	Description
101	A Clutch Control Valve
102	F Clutch Control Valve
103	C Clutch Control Valve
104	B Clutch Control Valve
105	E Clutch Control Valve
106	D Clutch Control Valve
107	LPC Anti-Back Flow Valve
108	TCC Priority Valve

OE Exploded View

Upper Valve Body • 10L80 (Gen. 1) Shown

NOTE: Depending upon vehicle application, the OE springs shown may not be present.

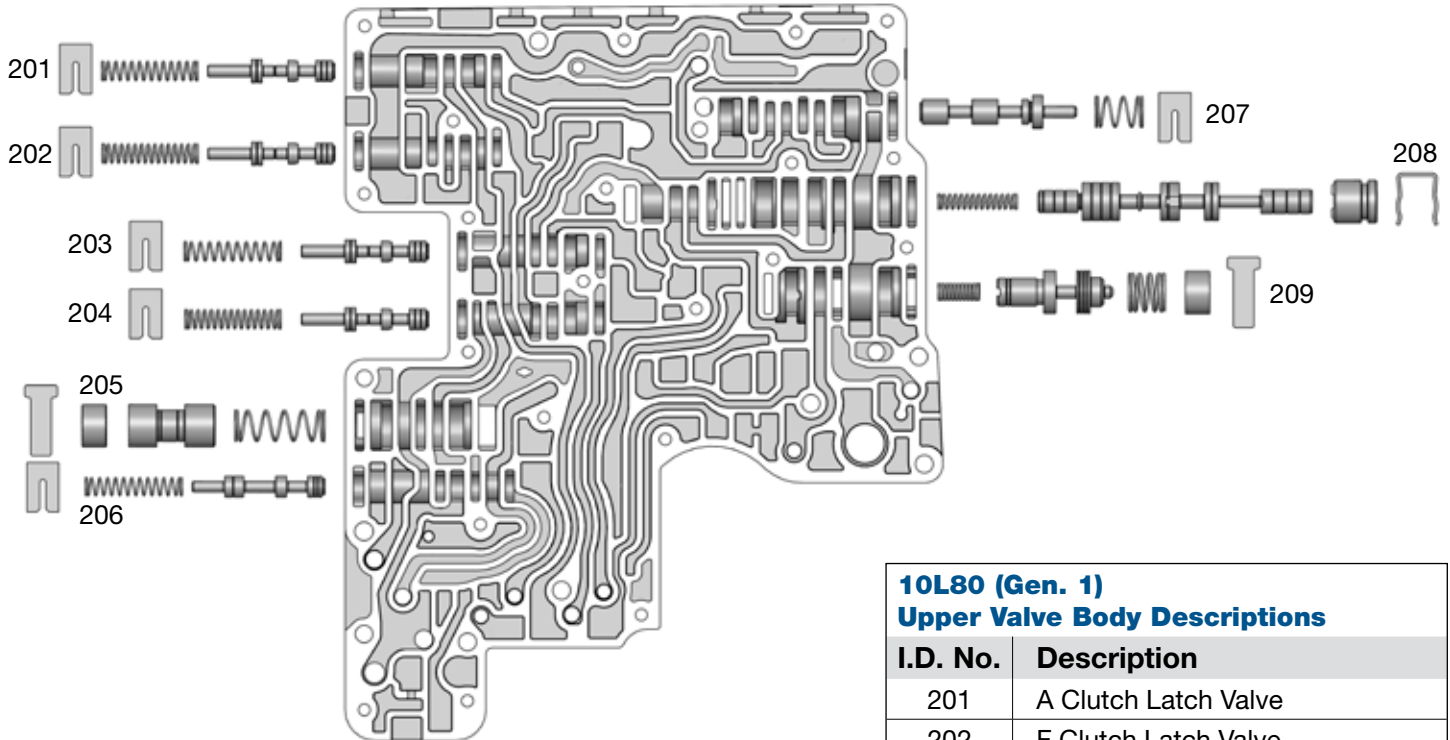

10L80 (Gen. 1) Upper Valve Body Descriptions

I.D. No.	Description
201	A Clutch Latch Valve
202	F Clutch Latch Valve
203	B Clutch Latch Valve
204	C Clutch Latch Valve
205	Bypass Valve
206	Lube Control Valve
207	Clutch Gain Control Valve
208	TCC Regulator Valve
209	Main Regulator Valve

