

TOYOTA/LEXUS UA80E, UA80F, UB80E, UB80F ZIP KIT®

PART NUMBER UA80E-UB80E-ZIP

QUICK GUIDE

Parts are labeled here in order of installation. See other side of sheet for details on kit contents.

INSTALLATION DIAGRAM

UB80E Solenoid Valve Body

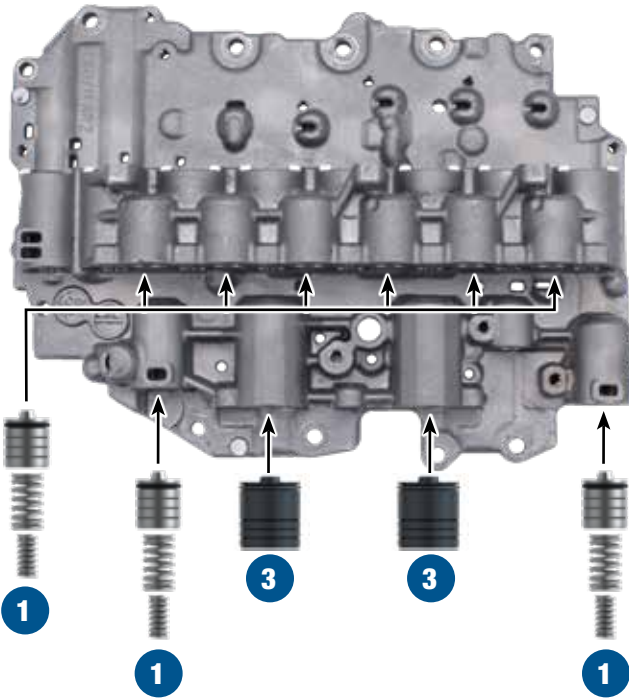

UB80E Middle Valve Body

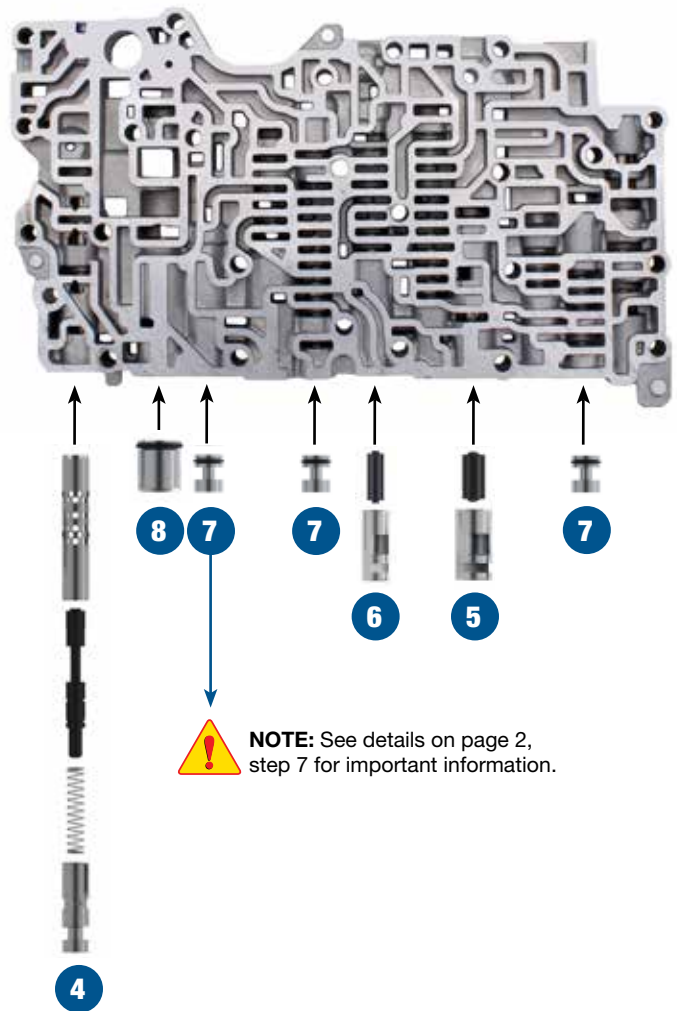

NOTE: See details on page 2, step 7 for important information.

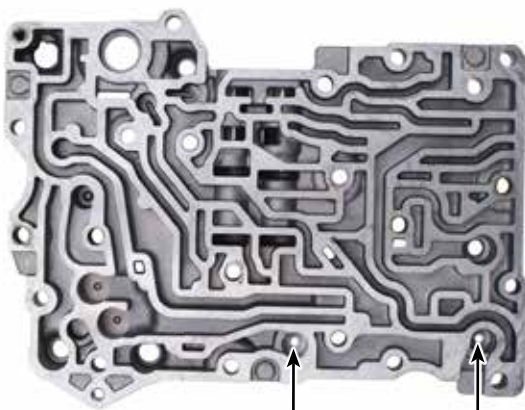

UB80E Rear Valve Body

2
TCCV

2
TCCR

In addition to general rebuilding tips and technical information, the technical booklet included in this kit contains vacuum testing and additional repair options for higher mileage units or for repairing specific complaints which are beyond the scope of this kit.

Kit Contents & Installation Steps

Step 1 Replace Solenoid Dampers

NOTE: The solenoid valve body has a total of (8) solenoid dampers, this Zip Kit contains (3) to refurbish the most worn. Refer to vacuum testing to determine the most worn to replace.

Remove retainer plate and pins. Place O-ring in groove on damper, lubricate with Sonnax Slippery Stick™ **O-LUBE** and roll on bench to size. Install O-ringed damper into bore, followed by large and small spring. Reinstall retainer plate and retaining pins.

Packaging Pocket 1

- Solenoid Dampers (3)
- Springs (3) Large
- Springs (3) Small
- O-Rings (6) 2 Extra

Step 2 Replace TCCRv & TCCV Dampers

Dampers are located in the rear valve body. Use a small amount of Sonnax Slippery Stick™ **O-LUBE** to lubricate the O-ring, piston/sleeve assembly and the valve body bore entrance. Install O-ring into the bore, gently pressing it down to the bottom of the bore. Install springs into the piston/sleeve assembly through the bottom. Install piston/sleeve assembly with spring into the bore.

Packaging Pocket 2

- Sleeves (2)
- Pistons (2)
- Spring (TCCV)
- Spring (TCCRv) Red
- O-Rings (4) 2 Extra

Step 3 Replace Forward & Reverse Accumulator Pistons

Place O-rings in groove, lubricate with Sonnax Slippery Stick™ **O-LUBE** and roll on bench to size. Install in bore, reuse OE springs and reinstall OE retainer pins.

Packaging Pocket 3

- Pistons (2)
- O-Rings (4) 2 Extra

Step 4 Replace Cooler Return Lube Flow Control Valve

Packaging Pocket 4

- Valve
- Sleeve
- Spring
- End Plug

NOTE: The parts listed here may be protected by patent 12,129,922.

Step 5 Replace C1 Apply Plunger Assembly

Packaging Pocket 5

- Valve
- Sleeve

Step 6 Replace C4 Apply Plunger Assembly

Packaging Pocket 6

- Valve
- Sleeve

Step 7 Replace Small End Plugs

Place O-rings in large groove, lubricate with Sonnax Slippery Stick™ **O-LUBE** and roll on bench to size. Install in bore and reinstall end plug retainers.

Packaging Pocket 7

- End Plugs (3)
- O-Rings (5) 2 Extra

NOTE: In the 4-way checkball assembly location, there is an early and a late version that has two different types of end plugs. The early is steel and the late is aluminum (**Figure 1**). The Sonnax O-ringed end plug can *only* be used on the aluminum end plug. Do not install in place of the steel end plug.

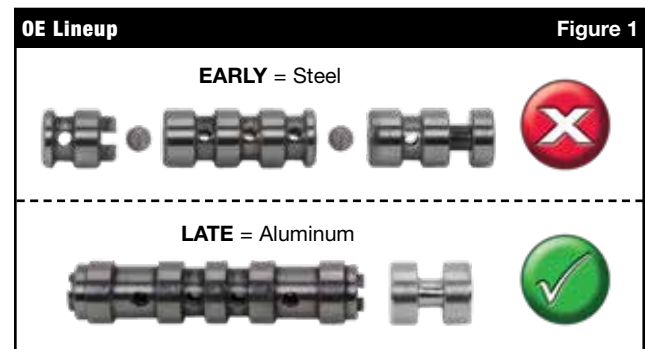

Step 8 Replace Large Pressure Regulator End Plug

Place O-rings in large groove, lubricate with Sonnax Slippery Stick™ **O-LUBE** and roll on bench to size. Install in bore and reinstall end plug retainers.

Packaging Pocket 8

- End Plug
- O-Rings (2) 1 Extra

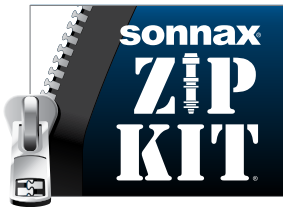

TOYOTA/LEXUS UA80E, UA80F; UB80E, UB80F ZIP KIT®

PART NUMBER UA80E-UB80E-ZIP

DIAGNOSTIC INFORMATION

UA80E-F & UB80E-F Diagnostic Information

1. Application Charts & Solenoid Information.

The UA80 is paired with V-6 applications. The UB80 is paired with 4 cylinder applications. Refer to **Figure 1** for Clutch and Brake application diagnostic information. **Figure 2** identifies solenoid types and ohm values for solenoid fault identification. **Figure 3** also shows solenoid applications to help track down a missing gear or upshift/downshift malfunctions.

2. Transmission Fill Information

- ATF Specifications: Dry fill 7.8 US quarts
- Fluid type: Toyota WS
- Fluid check plug (**Figure 4**) is at the bottom of the transmission where the two case halves meet.
- There is a stand pipe (under the plug) that will allow a small stream of fluid to flow when the fluid level is full (**Figure 5**).

NOTE: Engine must be at operating temperature and transmission fluid temp should be between 185-194°.

3. Reprogramming & Relearn Process:

After transmission overhaul or valve body replacement, it is important to install the scan tool and perform a transmission memory reset. After the reset it is necessary to bring engine temp up to between 140-212°.

Transmission fluid must be between 122-200°. Drive the vehicle for a minimum of 20 stops and starts at light acceleration through all 8 gears then downshift to a stop. After that it is necessary to go into passing gear downshift scenarios from 8 down to lower gears at least 5-6 times.

It is always helpful to see if there are any factory reflashes related to drive ability concerns to promote customer satisfaction.

Clutch & Brake Applications Figure 1

Gear	C-1	C-2	C-3	C-4	B-1	B-2
1st	On					On
2nd	On				On	
3rd	On		On			
4th	On			On		
5th	On	On				
6th		On		On		
7th		On	On			
8th		On			On	
Rev.			On			On

Solenoid Info & ohm Values Figure 2

Solenoid	Type	OHM Value
SL5	NL	5-6 ohms
SL6	NL	5-6 ohms
SL4	NL	5-6 ohms
SL3	NL	5-6 ohms
SL1	NL	5-6 ohms
SL2	NL	5-6 ohms
SLU	NL	5-6 ohms
SLT	NH	5-6 ohms
SL	NO	11-15 ohms

NL = Normally Low; NH = Normally High; NO = Normally Open

UA/UB80 Solenoid Applications Figure 3

Gear	SL5 (B1)	SL6 (B2)	SL4 (C3)	SL3 (C4)	SL1 (C1)	SL2 (C2)	SLU	SLT	SL
1st		High			High			Varying	**
2nd	High				High		H-*	Varying	
3rd			High		High		H-*	Varying	
4th				High	High		H-*	Varying	
5th					High	High	H-*	Varying	
6th				High		High	H-*	Varying	
7th			High			High	H-*	Varying	
8th	High					High	H-*	Varying	
Rev.		High	High					Varying	**

** = Can toggle On to Off from D or R to Park. H-* = Can come on in these ranges based on load.

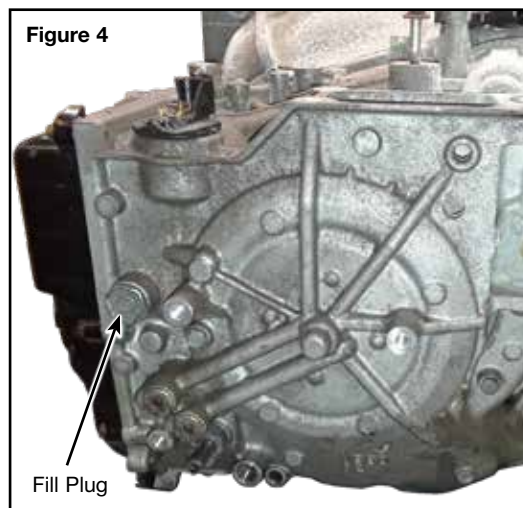

Figure 4

Fill Plug

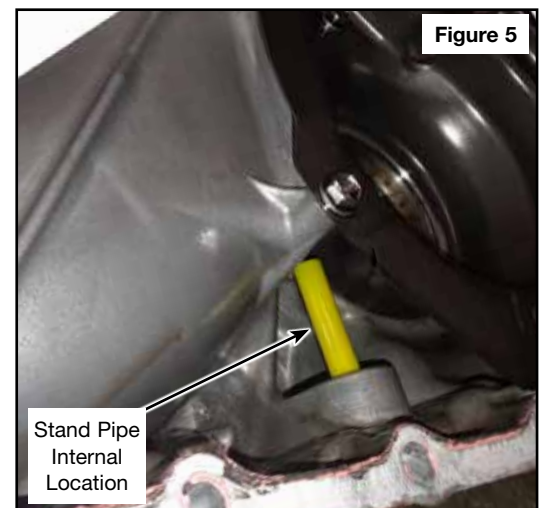
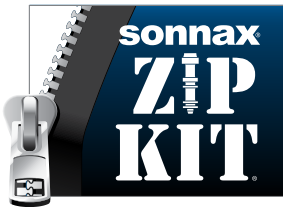

Figure 5

Stand Pipe
Internal
Location



TOYOTA/LEXUS UA80E, UA80F, UB80E, UB80F ZIP KIT®

PART NUMBER UA80E-UB80E-ZIP

INSTALLATION & TESTING BOOKLET

Zip Kit Instructions

1. Valve Body Removal from Case

a. Remove ten 10mm bolts (white circles, **Figure 1**).

NOTE: White circles with stars, require sealant on the threads when reassembled.

b. Disconnect plug (**Figure 2**).

c. Remove nine 10mm bolts, (yellow circles, **Figure 2**).

d. Remove 10mm bolt (**Figure 2**), then remove NT speed sensor.

e. Remove 8mm bolt (**Figure 2**).

f. Disconnect harness (**Figure 3**).

G. Remove valve body from case (**Figure 4**).

2. Removal of Wiring Harness

a. Disconnect SLU, SL5, SL6, SL4, SL3, SL1, SL2 & SLT plugs (**Figure 4**).

b. Disconnect SL plug.

c. Remove 2 short 8mm bolts near SL plug.

d. Remove 10mm bolt and bracket, remove sensor.



Figure 1

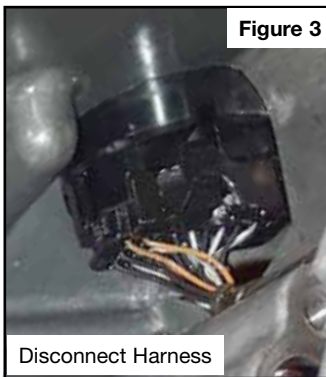

Figure 3

Disconnect Harness

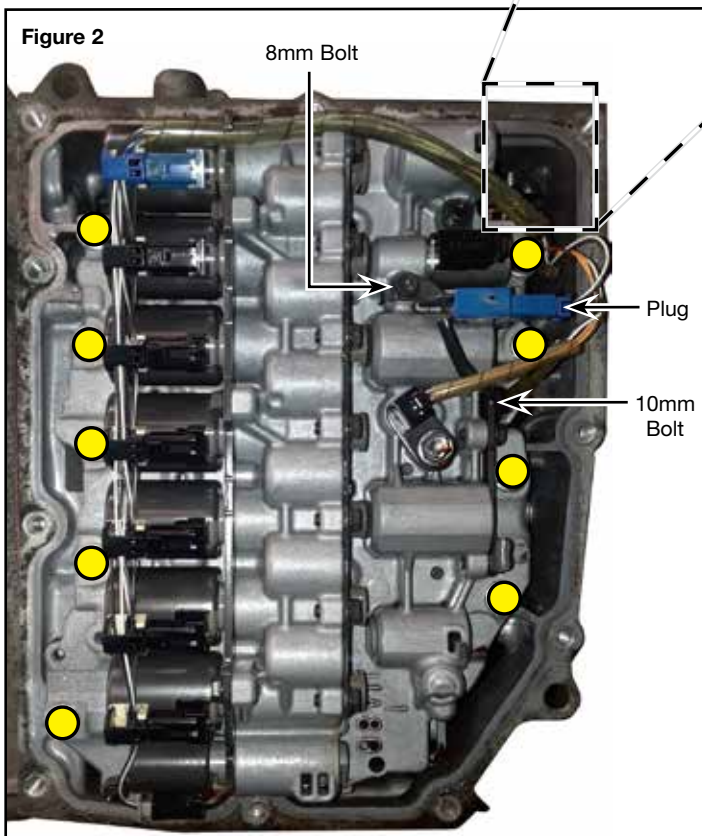

Figure 2

8mm Bolt

Plug

10mm Bolt

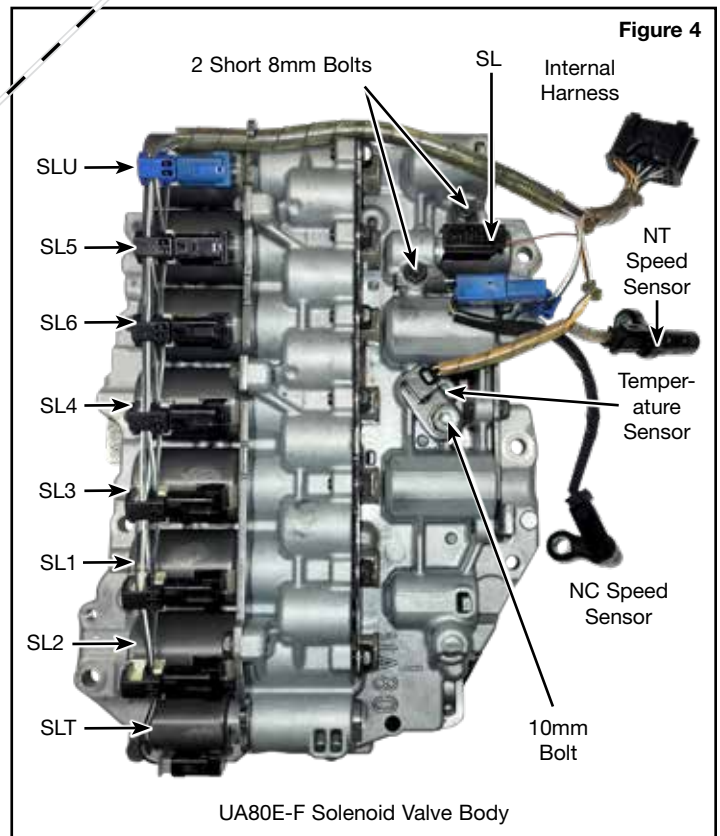

Figure 4

2 Short 8mm Bolts

SL

Internal Harness

SLU

SL5

SL6

SL4

SL3

SL1

SL2

SLT

NT Speed Sensor

Temperature Sensor

NC Speed Sensor

10mm Bolt

UA80E-F Solenoid Valve Body

3. Disassembly of Valve Body

Remove bottom 1.776" bolt first (Figure 5).

4. Rear & Middle Valve Body Section Removal

- a. Flip valve body over and remove all 8mm bolts and remove rear valve body section (yellow, red circles Figure 6).
- b. Once the rear valve body section is removed, note the locations of the small parts and plastic check valves to remove and save for later reinstallation (Figure 7).
- c. Remove the four 8mm bolts and remove the middle valve body section (purple circles, Figures 7).
- d. Disassembly is complete.

5. Rear Valve Body Section Removed

- a. Remove 8mm bolt and remove rear valve body separator plate (Figure 8).
- b. Note the location of the small parts in the rear valve body section for later reinstallation (Figure 9).

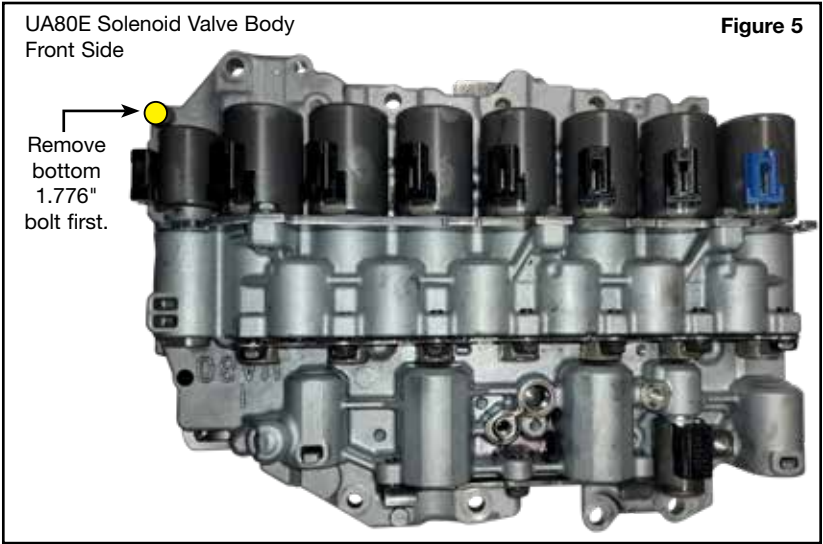

Figure 5

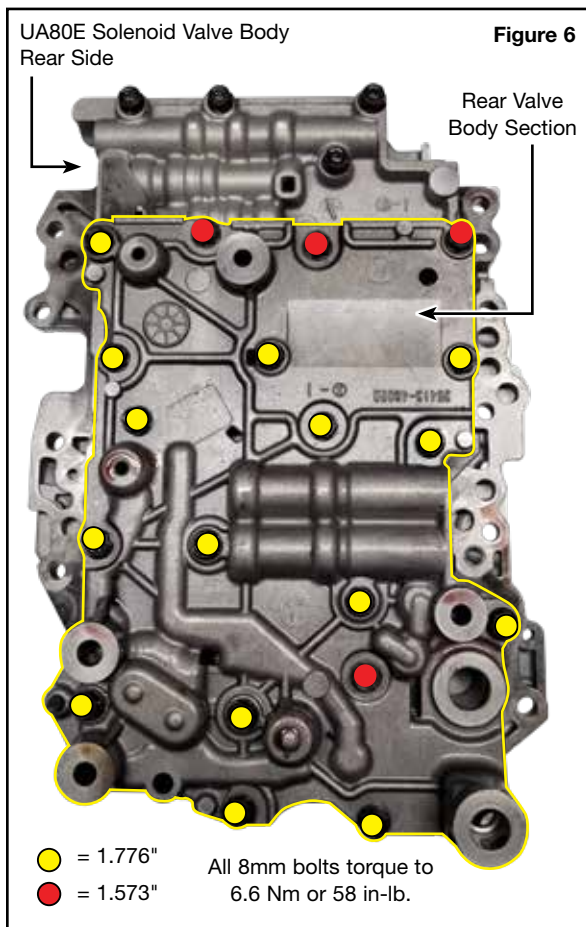

Figure 6

● = 1.776" All 8mm bolts torque to 6.6 Nm or 58 in-lb.
● = 1.573"

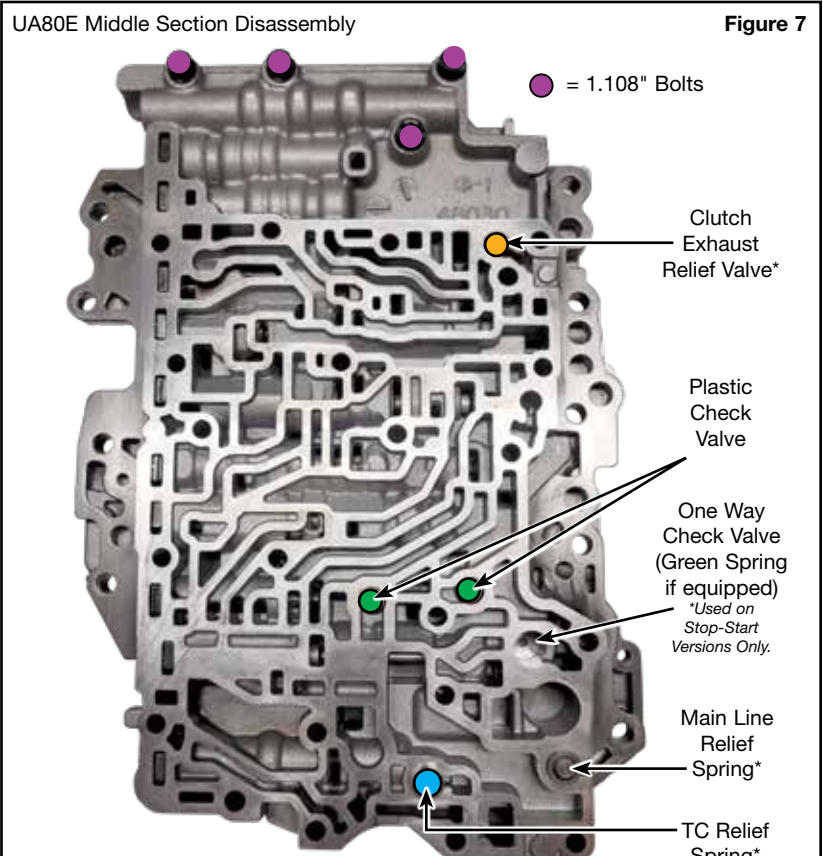

Figure 7

* = See Chart below for Measurements

	Clutch Exhaust Relief Valve Spring (no color)	Main Line Relief Spring (no color)	TC Relief Spring (white)
Overall Length	.487"	.434"	.650"
Outside Dia.	.197"	.374"	.235"
Wire Dia.	.017"	.050"	.038"



6. Middle Valve Body Removed

- a. Once the middle valve body is removed, slide the main separator plate off of the solenoid body to expose all of the small parts (Figure 11).

7. Clean and Rebuild Valve Body

- a. Clean all of the individual sections and parts then install Zip Kit components using the separate quick guide for locations of components.
- b. Detailed location of small parts are shown in each valve body section in this booklet.
- c. Sonnax also recommends vacuum testing the critical locations on pages 5 and 6.

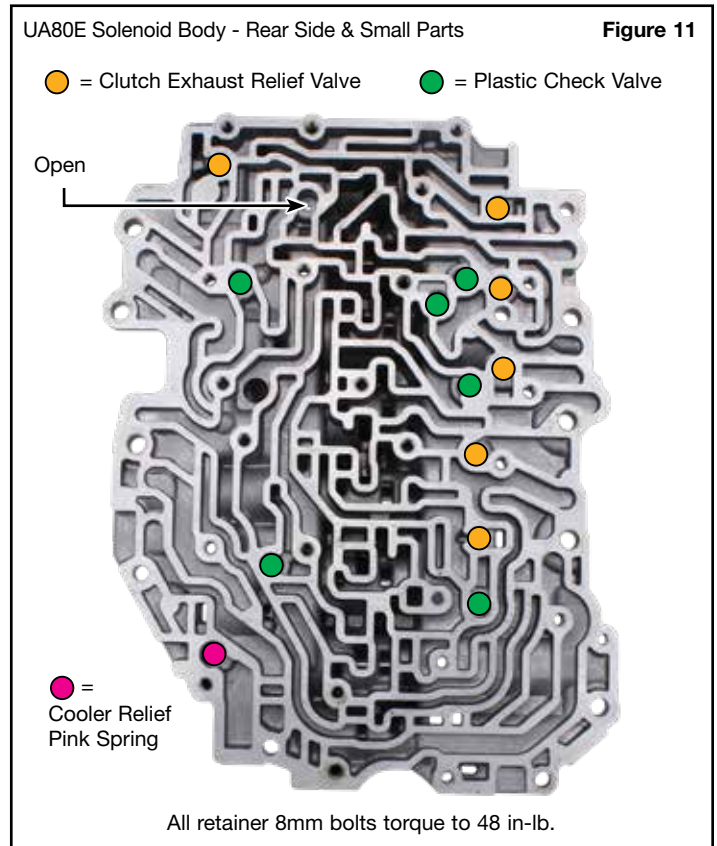
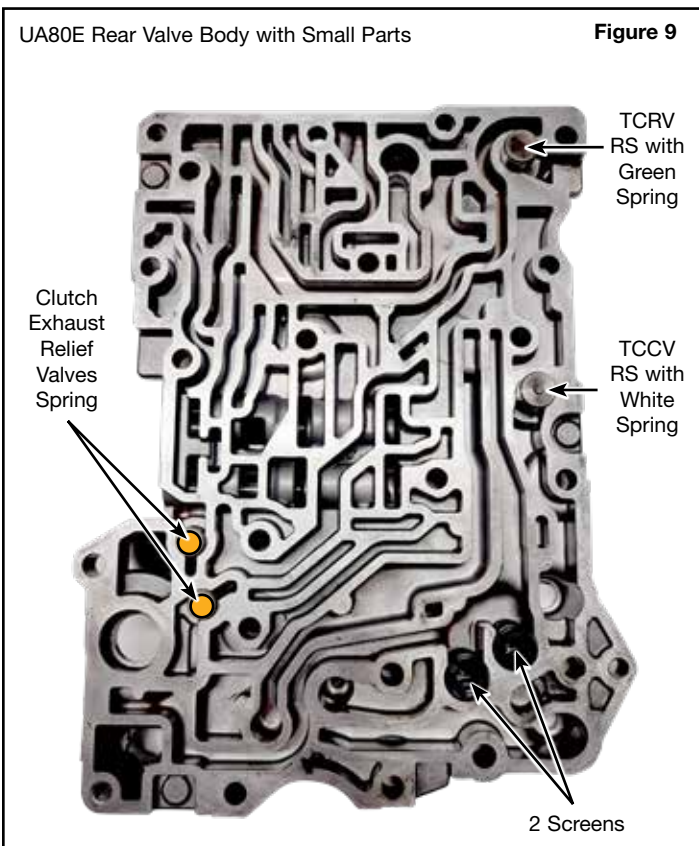

8. Valve Body Reassembly

- After the installation of the Zip Kit, reassemble the solenoids and accumulator pistons into their locations shown in the exploded view (page 8). Then install the solenoid and accumulator brackets and torque the small 8mm bolts to 48 in-lb (yellow circles, Figure 12).
- Reassemble all of the small parts back into the solenoid body (Figure 11). Install the separator plate onto the solenoid body (Figure 10).
- Install the middle valve body onto the solenoid body and separator plate then reinstall the small parts (Figure 7).
- Install the four bolts at the top of the middle valve body and snug them, do not tighten them down. Install all of the small parts into the rear side of the middle valve body (purple circles, Figure 7).
- Install all of the small parts into the rear valve body section as shown (Figure 9).
- Install the rear valve body separator plate and 8mm bolt and torque to 48 in-lb (Figure 8).
- Flip over the rear valve body section with plate and install the plate side of the rear valve body against the rear side of the middle valve body. Install all of the 8mm bolts into their locations (yellow, red circles, Figure 6) and the single bolt that comes in from the front side of the solenoid body (Figure 5). After all of the bolts are snugged down, torque them all to 58 in-lb including the bolts (purple circles, Figure 7) and the 1.776" bolt (yellow circle, Figure 5).

9. Valve Body Reassembly

Verify all of the case seals are in place (Figure 13).

NOTE: This can also be used to air test components in the case.

10. Reinstall valve body onto trasmission case

- After valve body is completely reassembled and all bolts are torqued back together, reinstall the wiring harness back onto the valve body reconnecting all of the solenoids and speed sensor connectors and temperature sensor (Figure 4). Install temperature sensor hold down bracket and bolt and torque to 58 in-lb.
- Assemble valve body onto the case and be sure to index the manual valve back into the manual linkage, and install the valve body-to-case bolts (Figure 2). After all of the valve body bolts are snugged down, torque them to 8 ft-lb.
- Install the main harness connector back into the case connector (Figure 3). Install the NT speed sensor and bolt and torque to 58 in-lb. Install the two 8mm bolts and torque to 58 in-lb. Be sure all of the harness connectors are reconnected.
- Install the front pan back onto the transmission case. Install the retaining bolts, see note in (Figure 1) that the bolts with the stars need to have a small amount of silicone or thread sealant applied to them, after that is accomplished torque all bolts to 8 ft-lb.

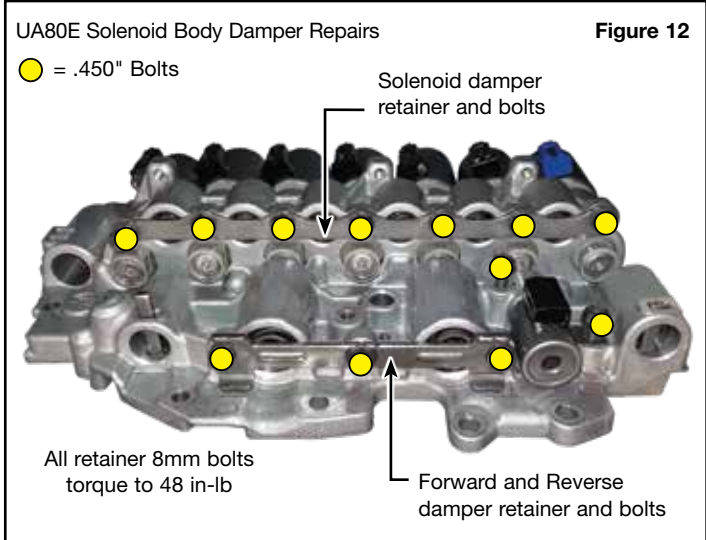

Figure 12

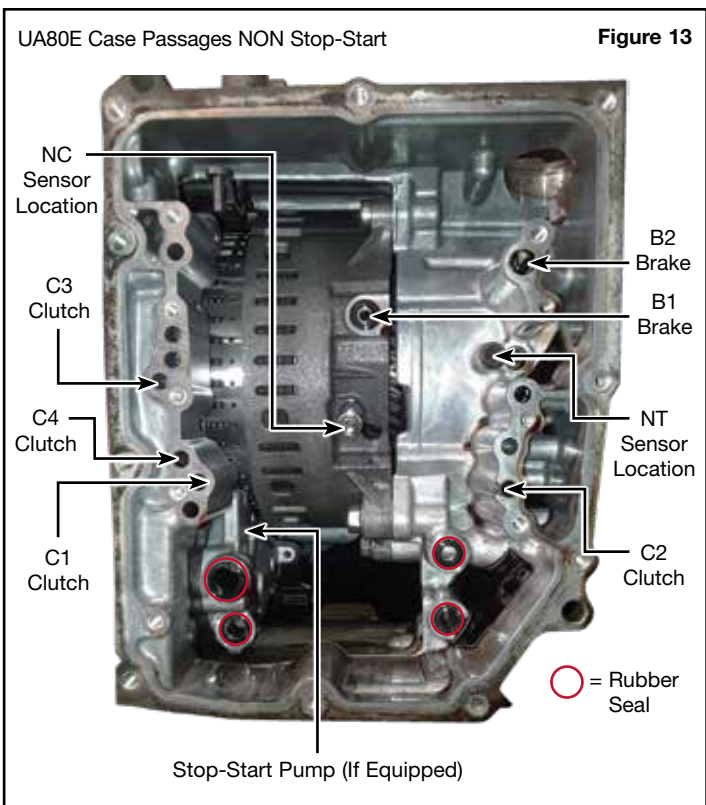

Figure 13

Critical Wear Areas & Vacuum Test Locations



NOTE: OE valves are shown in rest position and should be tested in rest position unless otherwise indicated. Test locations are pointed to with an arrow. Springs are not shown for visual clarity. Low vacuum reading indicates wear and Sonnax parts are noted for replacement.

Middle Valve Body • UA80E Shown

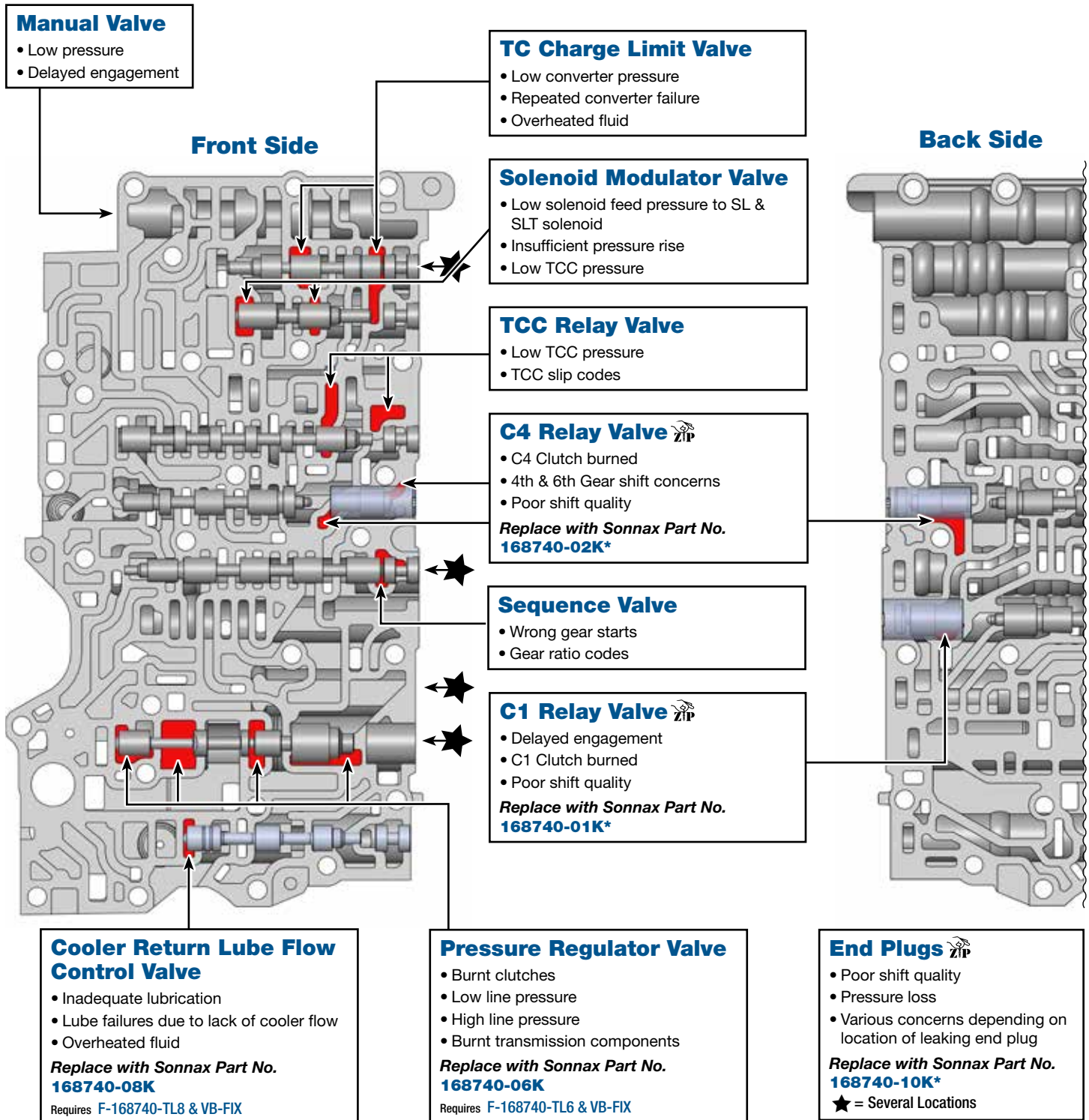

Part Numbers with an asterisk () are included in this Zip Kit.

Critical Wear Areas & Vacuum Test Locations



NOTE: OE valves are shown in rest position and should be tested in rest position unless otherwise indicated. Test locations are pointed to with an arrow. Springs are not shown for visual clarity. Low vacuum reading indicates wear and Sonnax parts are noted for replacement.

Rear Valve Body • UA80E Shown

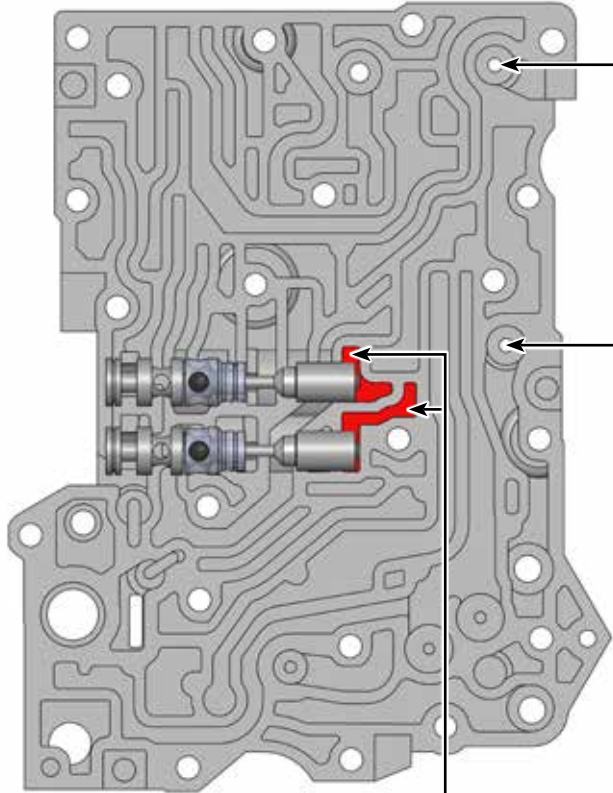

TCCRV & TCCV Damper

- Lube failures • Cooler drain back
- Overheated fluid/converter
- Delayed engagement

Replace with Sonnax Part No. 168740-11K*

Solenoid Damper

- Poor shift quality • Burnt clutches
- Delayed engagement
- Low line pressure
- TCC apply & release concerns
- Loss of shift solenoid control pressure

Replace with Sonnax Part No. 168740-12K*

B2/C1 One Way Check Valve

- Forward slip
- No Forward
- B2/C1 clutch failure

NOTE: Only on stop-start models. Valve bodies without stop-start will have open bores here.

Forward/Reverse Accumulators

- Slips in Forward & Reverse • Delayed engagement
- Poor shift quality • Harsh engagement

Replace with Sonnax Part No. 168740-05K*

**Solenoid Valve Body
UA80 Shown**

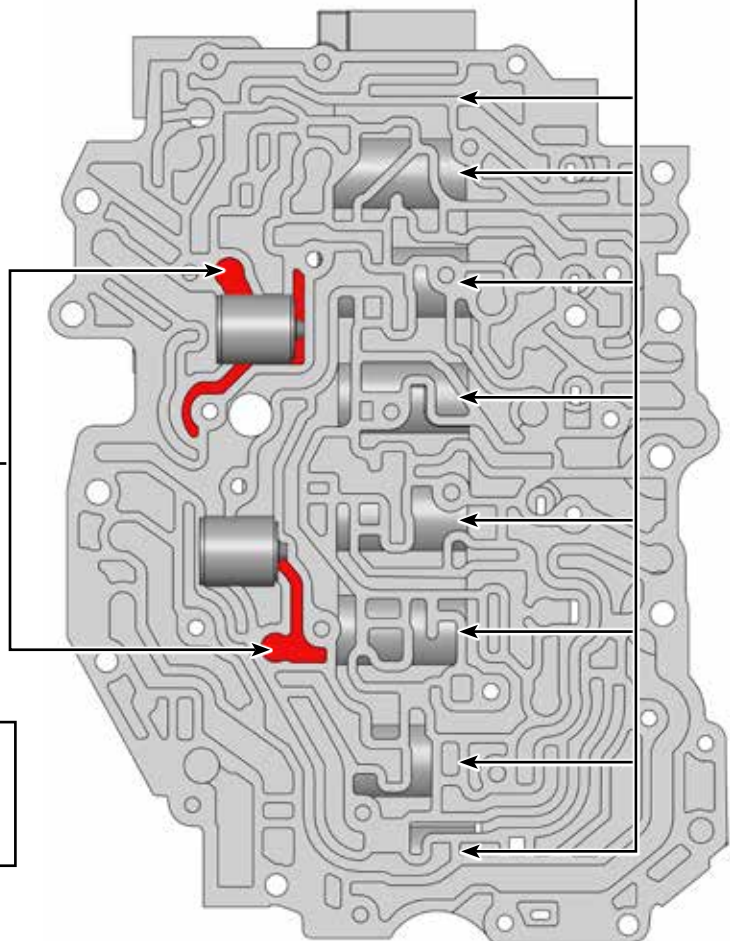

Part Numbers with an asterisk () are included in this Zip Kit.

OE Exploded View

Middle Valve Body (Front Side) • UA80E Shown

NOTE: Depending upon vehicle application, the OE springs shown may not be present.

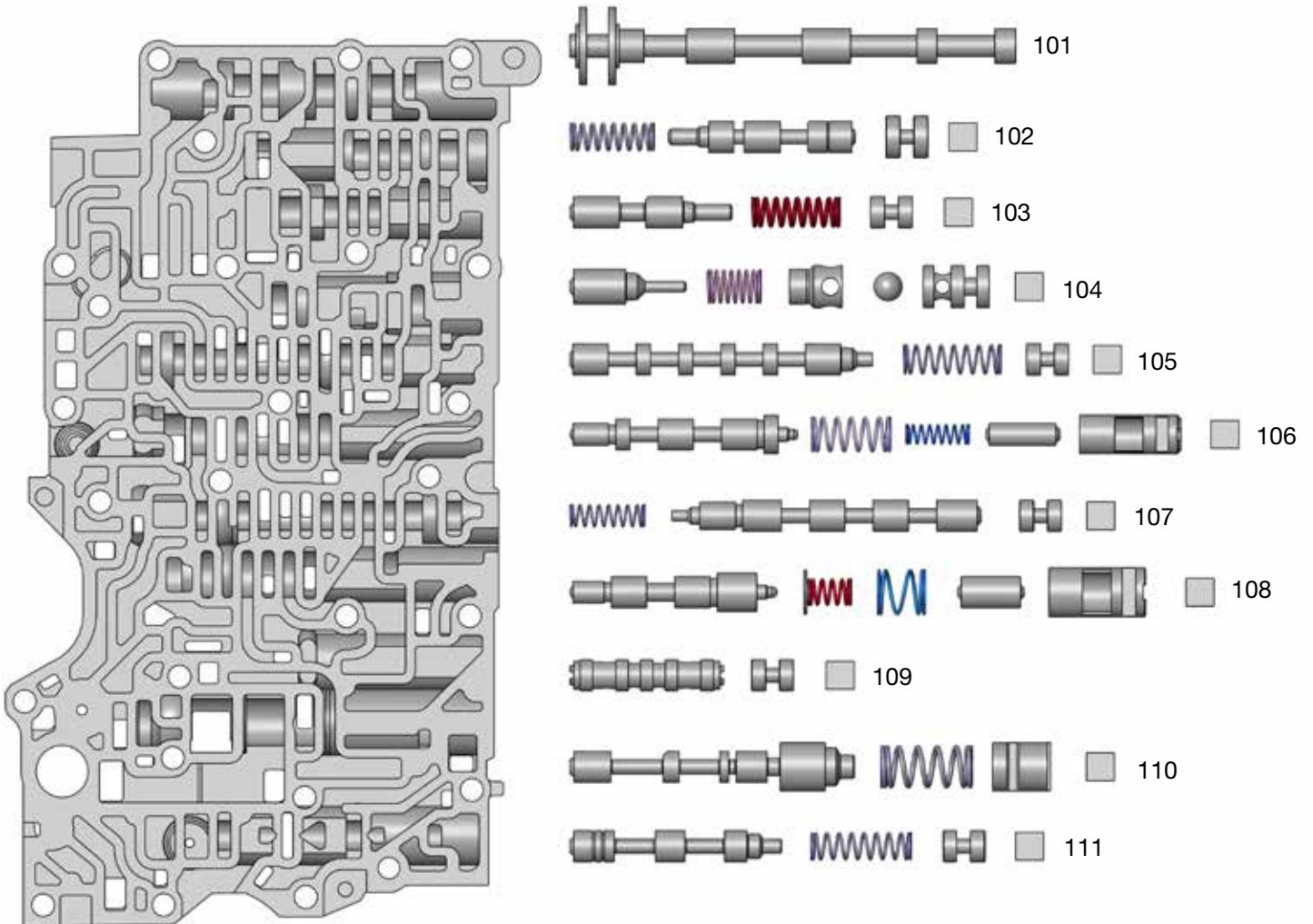

Middle Valve Body Descriptions

I.D. No.	Description
101	Manual Valve
102	TC Charge Limit Valve
103	Solenoid Modulator Valve
104	SL4/SL3 Shuttle Ball
105	TCC Relay Valve
106	C4 Relay Valve
107	Sequence Valve
108	C1 Relay Valve
109	4-Way Check Valve
110	Pressure Regulator Valve
111	Cooler Return Lube Flow Control Valve

Rear Valve Body • UA80E Shown

NOTE: 201 and 202 lineups are only for stop-start applications. If the transmission is not equipped with stop-start, the bores for 201 and 202 will be empty.

Rear Valve Body Descriptions

I.D. No.	Description
201	B2 One Way Check Valve
202	C1 One Way Check Valve
203	TCC Relief Valve (TCCRIV)
204	Transmission Cooler Check Valve (TCCV)

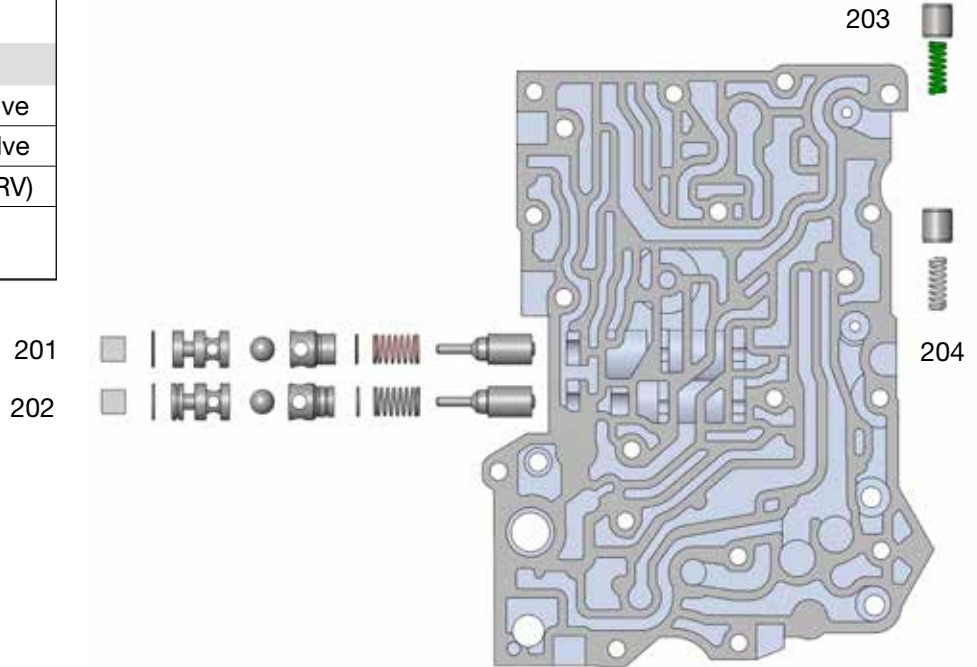

Solenoid Valve Body • UA80E Shown

NOTE: Depending upon vehicle application, the OE springs shown may not be present.

Solenoid Valve Body Descriptions

I.D. No.	Description
301	SLU Solenoid
302	SL5 Solenoid
303	SL6 Solenoid
304	SL4 Solenoid
305	SL3 Solenoid
306	SL1 Solenoid
307	SL2 Solenoid
308	SLT Solenoid
309	SL Damper & Springs
310	SLU Accumulator
311	SL Accumulator
312	Reverse Accumulator
313	Forward Accumulator
314	STL Accumulator

