

Oversized Torque Converter Pressure Regulator Valve Kit

Part No.

113741-13K



- Valve
- End Plug

NOTE: Also fits Mitsubishi F1CJA.

Tool Kit

Part No.

F-113741-TL13



- Reamers (2)
- Reamer Jig
- Guide Pin

NOTE: Tool kit for 113741-13K can also be used for 113741-15K

NOTE: Sonnax “F-Tool” kits designed to service a specific bore require the VB-FIX, a self-aligning valve body reaming fixture. More information and instructions can be found online at www.sonnax.com.

Jatco/Nissan JF011E (REOF10A)

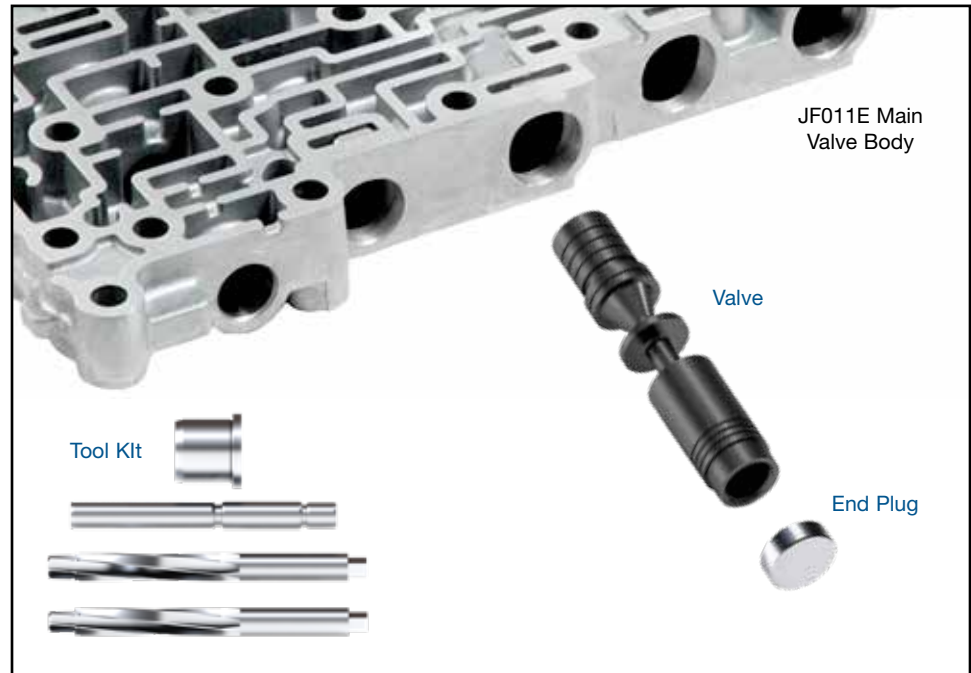

1. Disassembly

- Remove and discard OE valve and end plug.
- Save OE spring and retainer for reuse.

2. Bore Reaming



NOTE: Tool kit F-113741-13K contains two reamers. For JF011E valve bodies use reamer F-113741-RM13 ONLY.

Ream TC pressure regulator bore (for reaming instructions/reamer care, please visit www.sonnax.com). Sonnax reaming tool kit **F-113741-TL13** and **VB-FIX** are required for this operation.

3. Installation & Assembly

- Ensure all debris has been removed from valve bore and valve body.
- Install Sonnax regulator valve and OE spring.
- Install Sonnax end plug with the boss of the end plug inboard.
- Reinstall OE retaining clip.

4. Final Testing

Vacuum testing at the port(s) indicated holds the recommended minimum 18 in.-Hg.

