

K3 Clutch Control Valve Kit



Part No.
25741-08K

- Sleeve
- Valve
- Spring

Tool Kit



Part No.
F-25741-TL8

- Reamer
- Reamer Jig
- Guide Pin

NOTE: Sonnax “F-Tool” kits designed to service a specific bore require the VB-FIX, a self-aligning valve body reaming fixture. More information and instructions can be found online at www.sonnax.com.

Aisin AW TR-60SN; VW/Audi 09D

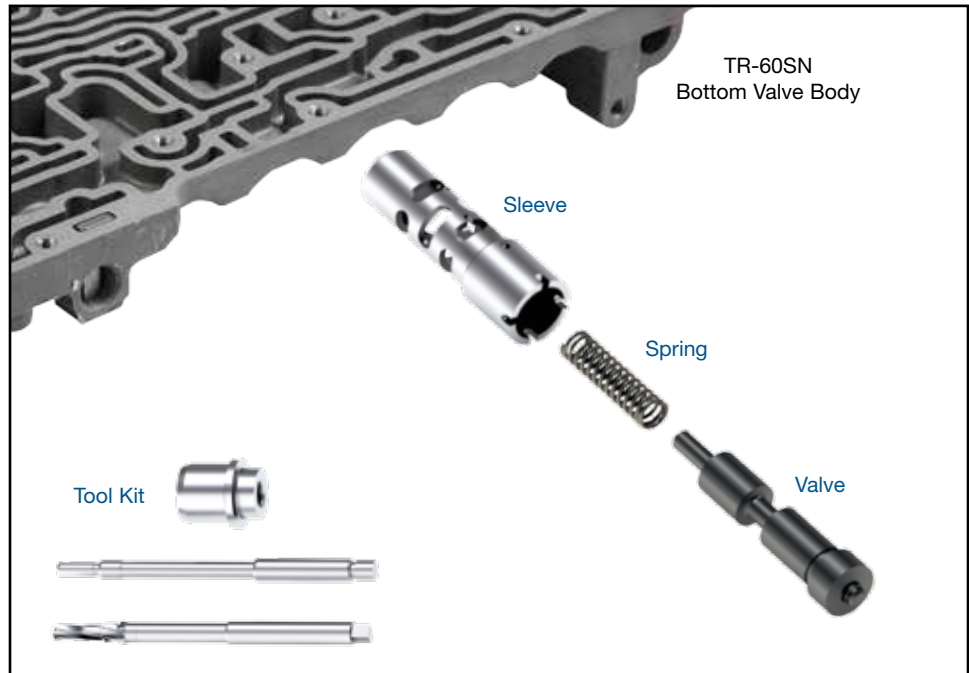

1. Disassembly

- Measure and record the distance from the end of the adjuster to the valve body casting (**Figure 1**).
- Remove solenoid retaining pin and solenoid, adjuster retainer and adjuster, and save all for re-assembly.
- Remove and discard OE valve and spring.

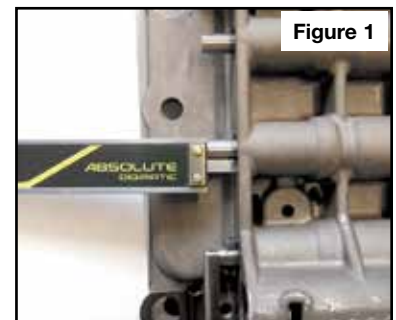

2. Bore Reaming

Ream K3 clutch control bore (for reaming instructions/reamer care, please visit www.sonnax.com). Sonnax reaming tool kit **F-25741-TL8** and **VB-FIX** are required for this operation.

3. Installation & Assembly

- Install adjuster to position previously recorded during disassembly procedure, followed by retainer.
- Install Sonnax spring into the adjuster pocket.
- Install Sonnax sleeve and valve, ensuring spring I.D. goes over valve nub. Note small sleeve and valve diameters should be installed nearest to adjuster.
- Reinstall the solenoid and solenoid retaining pin.

4. Final Testing

Vacuum testing at the port(s) indicated holds the recommended minimum 18 in-Hg.

