

Solenoid Modulator Accumulator Piston Kit

Part No.

39741-14K

- Accumulator Piston
- O-Ring

NOTE: Kit fits in either of two locations. Also fits in Ford (AF21) and Mazda (AW6A-EL) applications.

Aisin AW TF-81SC

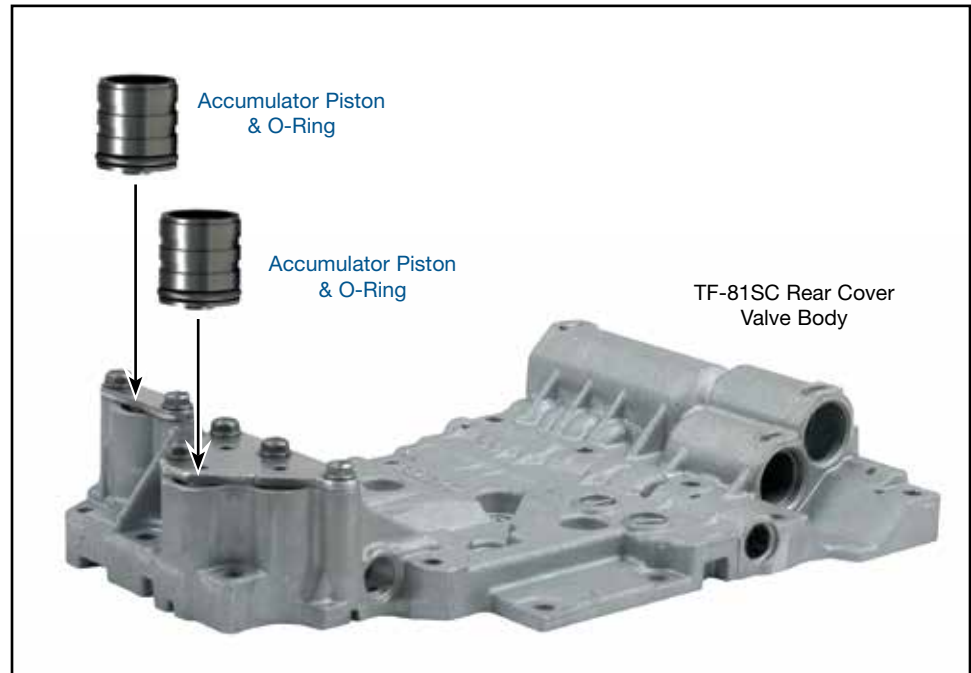

1. Disassembly

- Remove OE piston and springs.
- Discard OE piston.

2. Installation & Assembly



NOTE: The O-ring should not be installed on the piston unless there is severe wear or a ridge is worn near the bottom of the bore. If the O-ring is used, the bore surface must be buffed with 3M Scotchbrite or a similar material.

- If Sonnax O-ring is being installed, place it in Sonnax piston groove and roll on bench to size.
- Install Sonnax piston with O-Ring end first into the bore.



NOTE: After installing the piston, bottom it in the bore and insure it will not stick. You should be able to retract it with finger tension.

- Reinstall OE springs and retainer plates.

3. Final Testing

Vacuum testing at the port(s) indicated holds the recommended minimum 18 in-Hg.

