

Oversized Pressure Regulator Valve



Part No.
41954-01K

NOTE: May be used in Mitsubishi front-wheel drive, '96-later valve bodies including F4A41/42/51, F5A51 and Hyundai/Kia A5GF1 and A5HF1. However, OE valve spool diameters **MUST** be measured to verify application (**Figure 1**). This kit **CANNOT** be used in rear wheel or all wheel drive units.

Tool Kit



Part No.
F-41954-TL

- Reamer
- Reamer Jig
- Guide Pin

NOTE: Sonnax "F-Tool" kits designed to service a specific bore require the VB-FIX, a self-aligning valve body reaming fixture. More information and instructions can be found online at www.sonnax.com.

NOTE: Reamer kit **F-41954-TL** is no longer in production but may be available from distributor inventory.

Hyundai/Kia A5GF1, A5HF1; Mitsubishi F4A, F5A

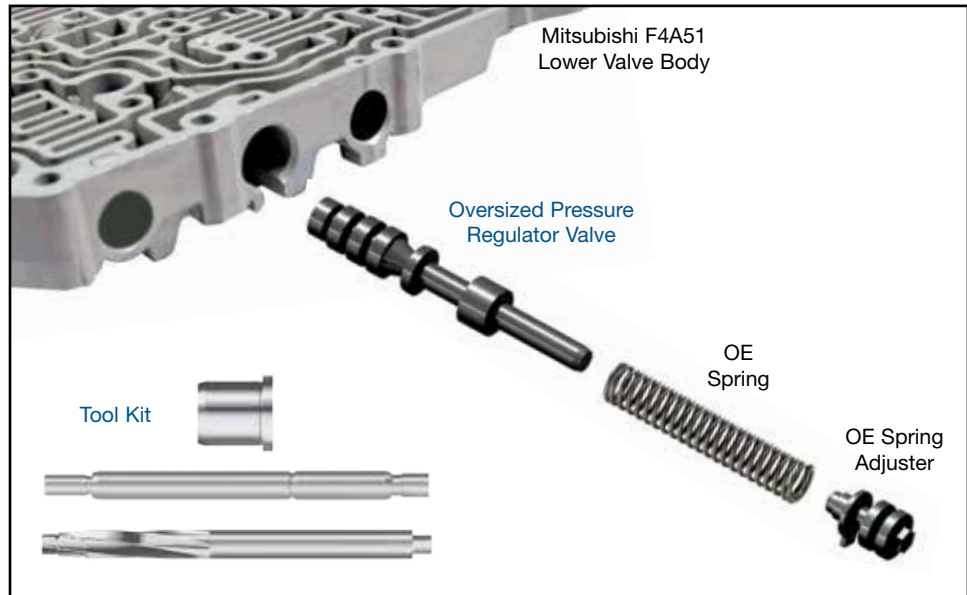
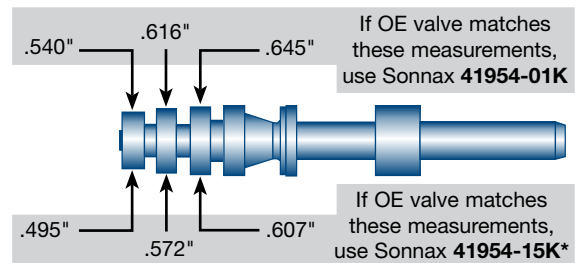

Figure 1

IMPORTANT: The OE valve spool diameters **MUST** be measured to verify application and therefore which Sonnax oversized pressure regulator valve will replace OE. Proper Sonnax valve and tool kit must be chosen **BEFORE** reaming the valve body.



***NOTE:** Sonnax kit **41954-15K** is no longer in production, but may be available from distributor inventory.

1. Disassembly

- Remove OE retainer and spring adjuster. Save both for reuse.



CAUTION: Do not turn the adjuster screw.

- Measure and record OE adjuster setting (**Figure 2**).
- Remove OE spring and pressure regulator valve. Discard valve and keep spring for reuse.

2. Bore Reaming

Ream pressure regulator bore (for reaming instructions/reamer care, please visit www.sonnax.com). Sonnax reaming tool kit **F-41954-TL** and **VB-FIX** are required for this operation.

Figure 2



3. Installation & Assembly

- Ensure valve bore and body are clean and clear of debris.
- Install Sonnax valve.
- Reinstall OE spring.
- Before reinstalling OE spring adjuster, verify it is set to the measurement noted during disassembly (**Figure 2**). If that setting is unknown, set the spring adjuster assembly to .250".



NOTE: If adjuster setting was not noted, pressure must be verified after repair. One revolution of the adjuster will change idle pressure by approximately 5 psi. Line pressure should be 145 psi in D1 at idle; 185 in Reverse at idle; 260 maximum line.

- Reinstall OE spring adjuster and retainer.

4. Final Testing

Vacuum testing at the port(s) indicated holds the recommended minimum 18 in-Hg or more (**Figure 3**).

