

## Oversized Pressure Regulator Valve



**Part No.**

**92835-24**

**NOTE:** Does not fit units with variable line pressure (VLP). VLP units can be identified by the presence of the line pressure solenoid and transducer mounted on the valve body. Units with VLP can be serviced using **92835-29**.

## Tool Kit



**Part No.**

**F-92835-TL24**

- Reamer
- Reamer Jig
- Guide Pin
- Reamer Stop Pin

**NOTE:** Sonnax "F-Tool" kits designed to service a specific bore require the VB-FIX, a self-aligning valve body reaming fixture. More information and instructions can be found online at [www.sonnax.com](http://www.sonnax.com).

### Also Available

**Pressure Regulator Sleeve**  
**92835-07**

**Oversized Pressure Regulator Valve**  
**92835-29**

Services VLP Units

## Chrysler 40TE, 41AE, 41TE, 42LE, 42RLE

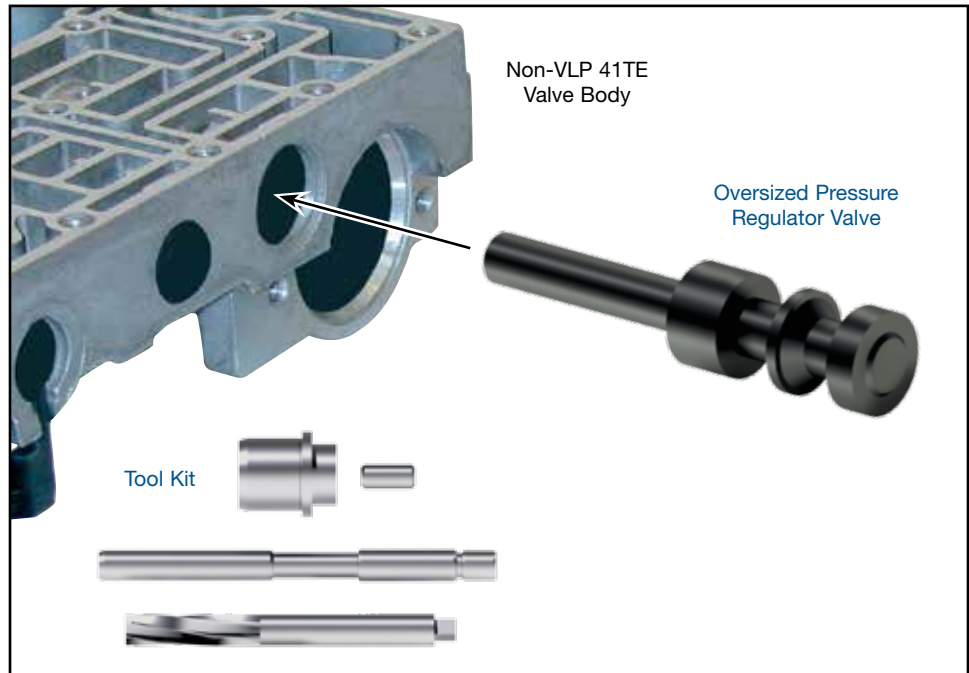

### 1. Disassembly

- Remove OE spring retainer and pressure regulator spring, saving both for reuse.
- Remove OE valve retainer, end plug and pressure regulator sleeve assembly. Save for reuse.
- Remove and discard OE pressure regulator valve.

### 2. Bore Reaming

Ream pressure regulator bore (for reaming instructions/reamer care, please visit [www.sonnax.com](http://www.sonnax.com)). Sonnax reaming tool kit **F-92835-TL24** and **VB-FIX** are required for this operation.

Sonnax tool kit **F-92835-TL24**

requires the use of a reamer stop pin (included) and the OE spring retainer clip (**Figure 1**).

- Insert the small OE spring retainer clip into the spring retaining channel.
- Insert Sonnax reamer stop pin into pressure regulator bore from the larger outer diameter.
- Proceed to ream the bore until the reamer contacts the reamer stop pin.

### 3. Installation & Assembly

- Remove the OE spring retainer and the reamer stop pin.

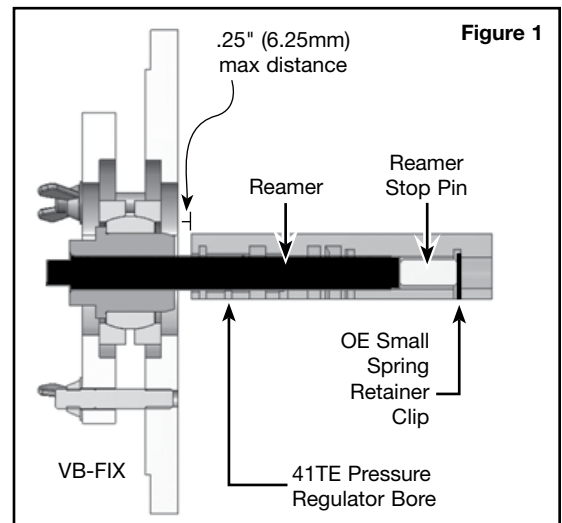

### 3. Installation & Assembly (continued)

- b. Thoroughly clean valve body and bore.
- c. Install Sonnax valve.
- d. Re-install the OE pressure regulator sleeve assembly, end plug and valve retainer.
- e. Re-install OE pressure regulator spring from far side of valve body.
- f. Re-install OE spring retainer.

### 4. Final Testing

Vacuum testing at the port(s) indicated holds the recommended minimum 14 in-Hg (Figure 2).

