

Oversized Solenoid Modulator Valve Kit

Part No.
94987-14K



- Oversized Modulator Valve
- Spring
- Oversized End Plug

NOTE: This kit fits '98-later models: Isuzu NPR, GMC Forward Tiltmaster, Chevrolet Forward, Nissan UD and Mitsubishi Fuso Trucks.

Tool Kit

Part No.
F-94987-TL14



- Reamer
- Reamer Jig
- Guide Pin

NOTE: Sonnax "F-Tool" kits designed to service a specific bore require the VB-FIX, a self-aligning valve body reaming fixture. More information and instructions can be found online at www.sonnax.com.

Aisin AW 450-43LE

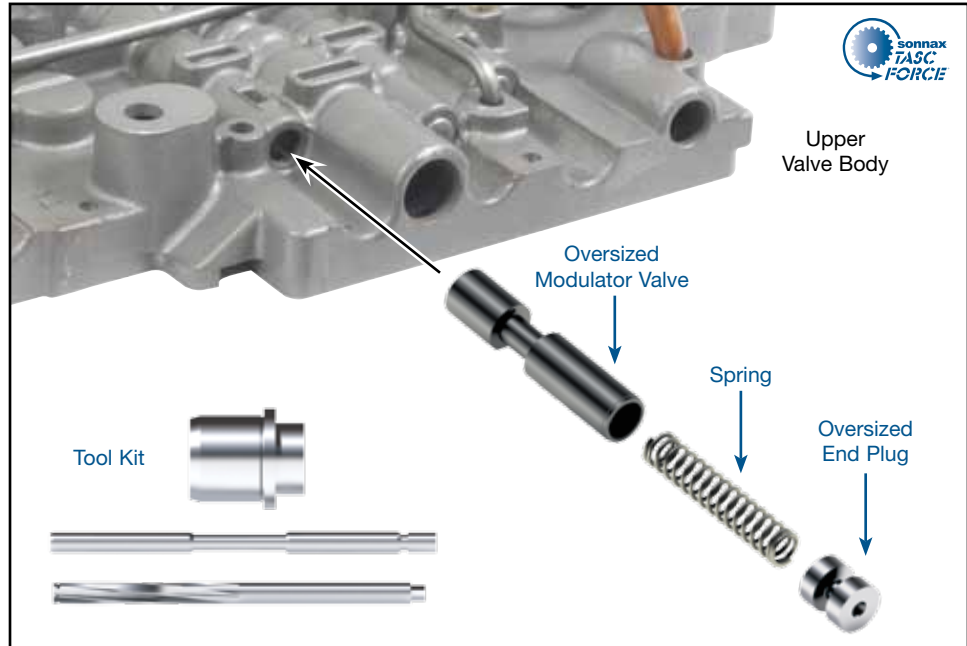

1. Disassembly

- Remove OE retainer and save for reuse.
- Remove and discard OE valve, end plug and spring.

2. Bore Preparation

- Clean the bore thoroughly in a solvent tank.
- Generously lubricate the bore and reamer with cutting fluid (i.e. Mobilmet S-122, Lubgard® Bio-Tap, Tap Magic™, etc.). For best results, provide a continuous flow of water-soluble cutting fluid (i.e. Mobilmet S-122) during the reaming process.
- The reamers should be turned using a low RPM, high-torque air drill regulated to a maximum of 200 RPM.
- Examine the bore after cleaning for surface finish, debris and burrs. Flashing and burrs on the exit side of land and in bores must be carefully removed. A small piece of Scotch-Brite™ material attached to a wire and powered with a drill motor is ideal for the task. Scotch-Brite™ is a very abrasive material and all residual debris must be cleaned to ensure particles do not migrate or remain imbedded into the surface. Post cleaning involves several progressive steps with solvent on a lint-free rag.

CAUTIONS AND SUGGESTIONS:

- Turning the reamer backward will dull it prematurely.
- Pushing on reamer will result in poor surface finish and inadequate and sporadic material removal.
- Never use a crescent wrench, ratchet or pliers to turn the reamer.
- A dull reamer will cut a smaller hole. Reamers can be sharpened, but should only be done by a professional tool sharpener. Actual life of a Sonnax reamer before resharpening or replacing averages 50-70 bores.

3. Bore Reaming

Use the associated “F-Tool” F-94987-TL14 kit and VB-FIX reaming fixture as illustrated below to ream the bore.

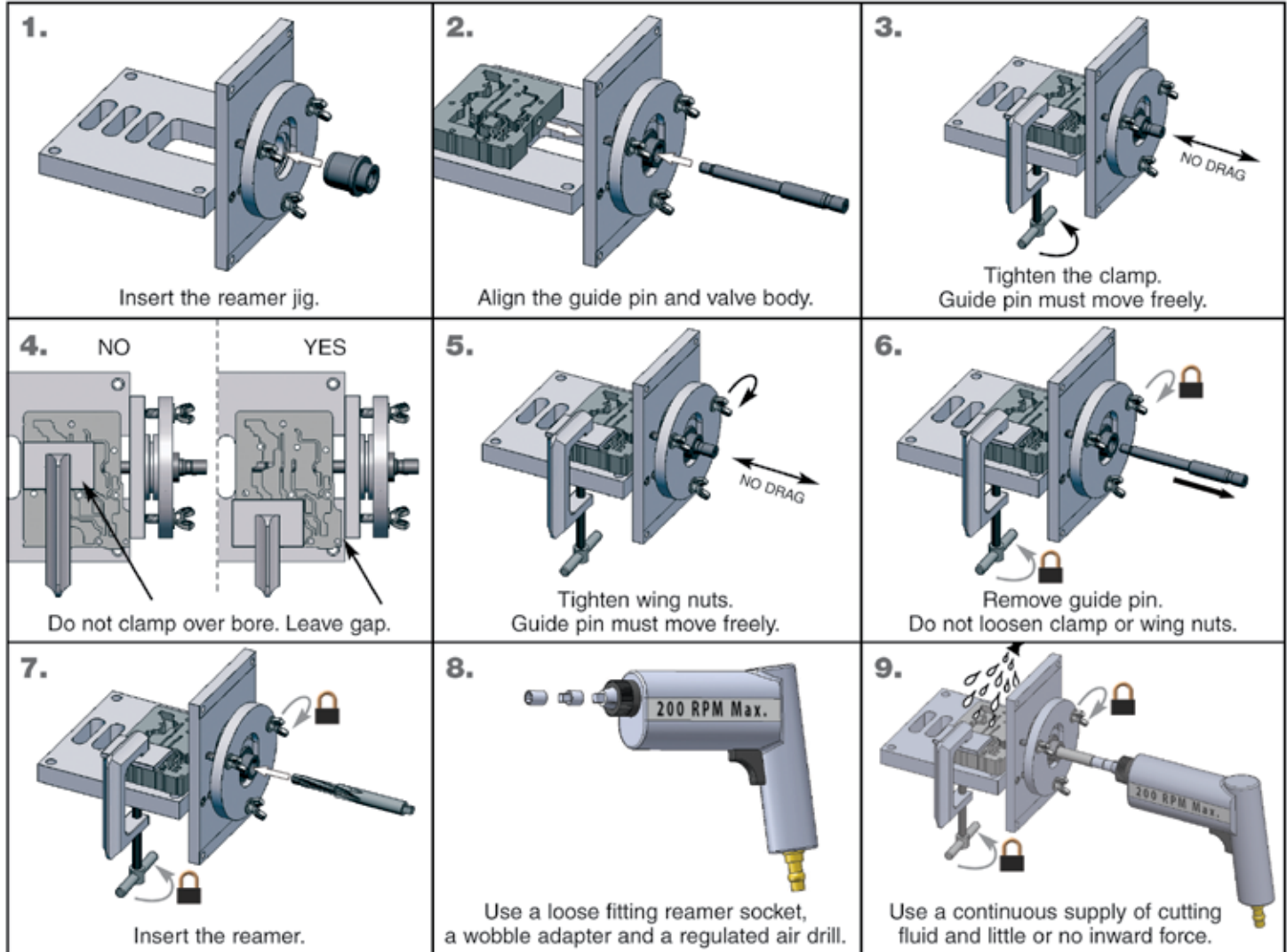

4. Installation & Assembly

- Install Sonnax oversized solenoid modulator valve into the bore.
- Install Sonnax spring and ensure it is seated inside the valve spring pocket.
- Install Sonnax oversized end plug and secure with the OE retainer.

5. Final Testing

A vacuum test at the port indicated holds 18 in-Hg or more.

