

GM 6L45, 6L50, 6L80, 6L90

Pressure Regulator Valve Kit

Part No.
104520-03K

- Valve
- Checkballs (2) 1 Extra
- Drill Bit

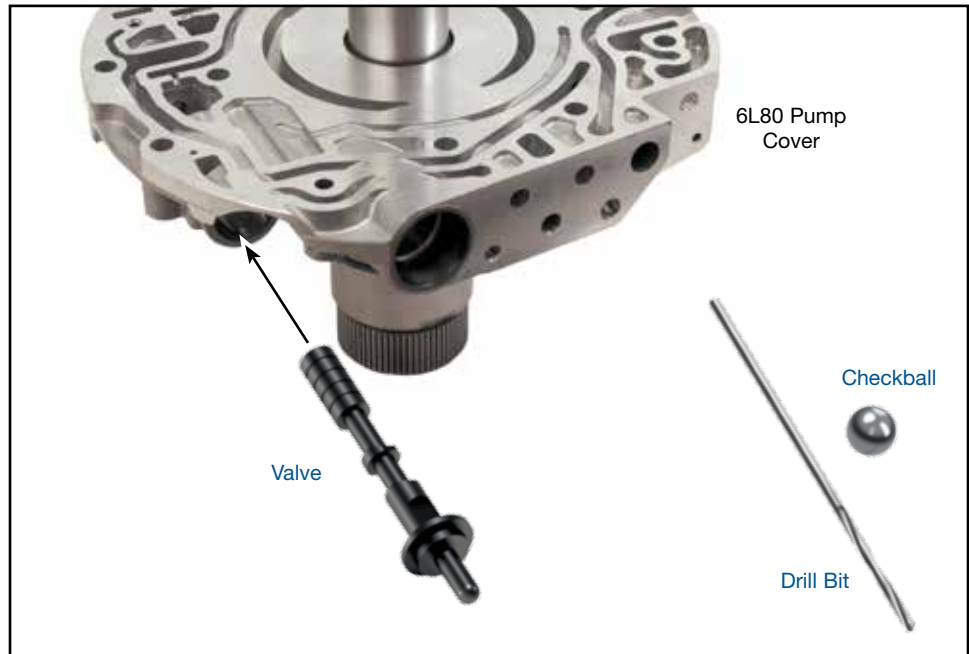

NOTE: In GM 6L45, 6L50, 6L80 and 6L90 units the pressure regulator valve and boost assembly are located in the pump cover. Transmission must be removed from the vehicle to access pump and replace the pressure regulator valve.

1. Disassembly

- a. Remove OE retaining pin, boost assembly and springs and save for reuse.
- b. Remove and discard OE pressure regulator valve.

2. Reroute Pressure Regulator Balance Feed Passage

- a. Locate OE balance feed orificed cup plug and adjacent inboard balance port for the pressure regulator valve.
- b. Drop one Sonnax 1/8" aluminum checkball into OE orificed cup plug. Drive checkball into cup plug with appropriately sized punch. Stake cup plug to prevent checkball displacement (**Figure 1**).
- c. Using included Sonnax drill bit, bore a new orifice from the cup plug bore to inboard balance port at an approximate 45° angle. Starting drill bit on countersunk surface of cup plug bore works best (**Figure 2**).
- d. Clean bore thoroughly, removing all debris and chips.



6L80 Pump Cover

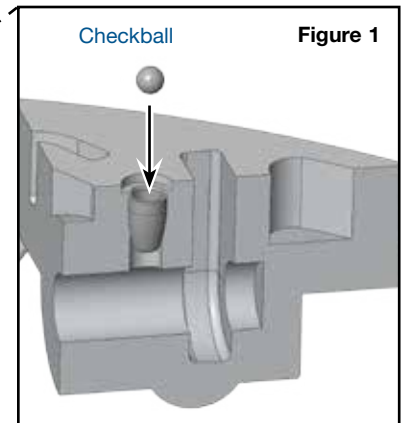

Figure 1

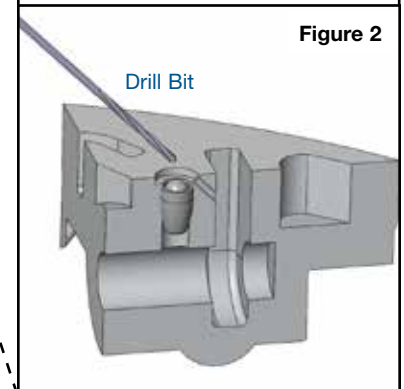

Figure 2

3. Installation & Assembly

- a. Install Sonnax pressure regulator valve.
- b. Reinstall OE springs (smaller first, then larger).
- c. Reinstall OE boost assembly or replace with Sonnax boost valve kit, available separately.
- d. Secure valve train components with OE retaining pin.

4. Final Testing

Vacuum testing at the port(s) indicated holds the recommended minimum 18 in-Hg (**Figure 3**).

