



AW55-50SN, AW55-51SN, AF23/33, RE5F22A ZIP KIT®

PART NUMBER AW55-50SN-ZIP

QUICK GUIDE

Parts are labeled here in order of installation. See other side of sheet for details on kit contents.

INSTALLATION DIAGRAM

Front Control Valve Body

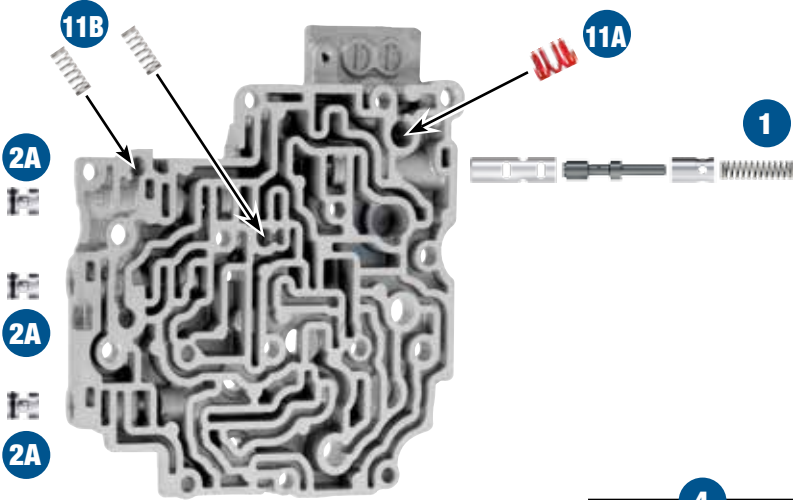

Middle Control Valve Body (Back)

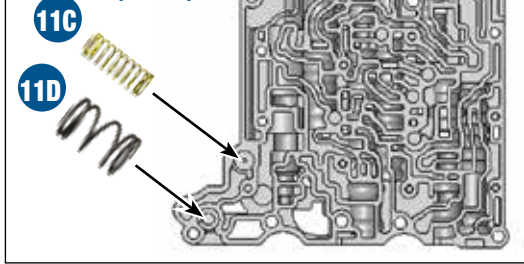

Middle Control Valve Body (Front)



! Before removing OE boost sleeve, take note of the adjustable step/retainer location and ensure the Sonnax sleeve is installed at the same height/location. Failure to do so will result in incorrect line rise.

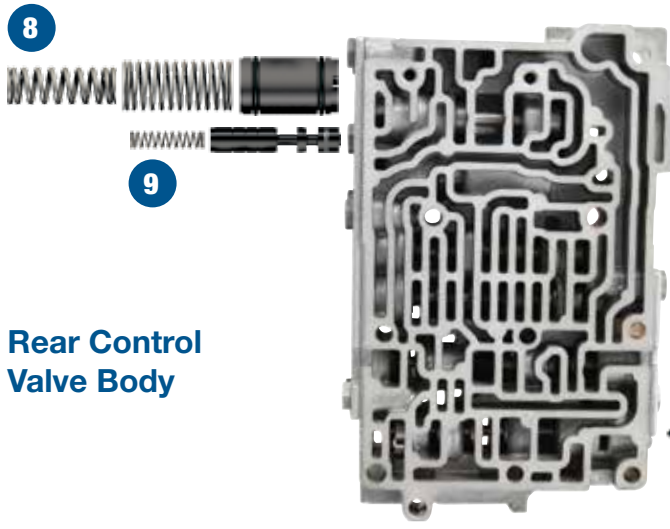
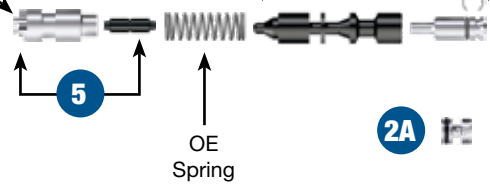

! Spring not utilized in all units. See step seven of installation steps on page two for details.

2nd Rear Control Valve Body

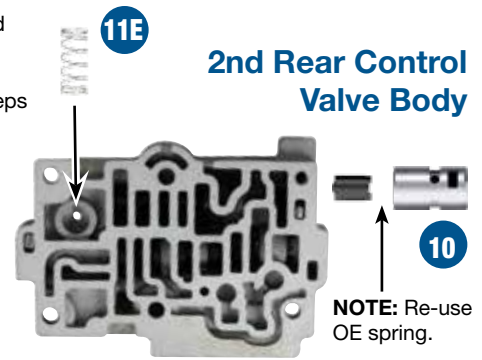

NOTE: Re-use OE spring.

In addition to general rebuilding tips and technical information, the technical booklet included in this kit contains vacuum testing and additional repair options for higher mileage units or for repairing specific complaints which are beyond the scope of this kit.

Kit Contents & Installation Steps

Step 1 Replace OE Solenoid Modulator Line-up

NOTE: Remove all OE bore components. Discard all except OE end plug and retainer which will be reused.

Install Sonnax solenoid modulator valve assembly with open end outboard, followed by the spacer sleeve also with orificed end outboard. Install Sonnax spring. Reinstall OE end plug and retainer.

Packaging Pocket 1

- Valve
- Valve Sleeve
- Spacer Sleeve
- Spring

Step 2 Replace OE End Plugs

Place O-rings into shallow grooves on end plugs. Lubricate with Sonnax slippery stick O-LUBE. Roll on bench to size. Install end plugs with the O-ring end outboard.

Packaging Pocket 2

- 2A.** • End Plugs, Small (4)
- O-Rings, Small (6) 2 extra
- 2B.** • End Plugs, Large
- O-Rings, Large (2) 1 extra

Step 3 Replace OE Solenoid Relay Assembly

Packaging Pocket 3

- Valve
- Sleeve

Step 4 Replace OE Pressure Regulator Valve

CAUTION: Before removing OE boost sleeve, take note of the adjustable step/retainer location and ensure the Sonnax sleeve is installed at the same height/location. Failure to do so will result in incorrect line rise.

NOTE: Remove all OE bore components. Discard all except OE spring and retainer to use in Step 5.

Place O-ring into single, deep and narrow groove on balance pin. Lubricate with Sonnax slippery stick O-LUBE. Roll on bench to size. Install balance pin into pressure regulator valve, then install assembly into bore. Retain balance pin in the bottom of the bore with retaining clip. Make sure clip fits in groove securely. Due to casting variations, filing a small amount of material from the inboard face of the balance pin may be required. Remove only enough material to securely install the clip. For vacuum testing of the Sonnax valve, only the inboard (balance) and outboard/spring (SLT) locations need to be checked.

Packaging Pocket 4

- PR Valve
- Balance Pin
- O-Rings (2) 1 extra
- Retaining Clip

Step 5 Replace OE Boost Valve Assy

Place OE spring over open end of boost sleeve. Install spring end first and retain in bore with OE retainer. Make sure to install the Sonnax sleeve at the same height/location as the OE sleeve.

Packaging Pocket 5

- Valve
- Sleeve

NOTE: The parts listed here may be protected by patents 8,919,381 & 9,746,089.

Step 6 Replace OE Lockup Relay Control Valve

Packaging Pocket 6

- Valve
- Sleeve

Step 7 Replace OE B5 Control Valve Spring



CAUTION: This spring is used in "B" or "C" valve body castings only (Figures 1 and 4 of Installation and Testing booklet show I.D. location). If your B5 control valve did not originally use a spring ("A" casting or no letter), DO NOT install Sonnax spring.

If an "A" or no-letter casting core is to be used in a vehicle that originally contained a "B" or "C" casting, spring must be installed. Position spring on inboard end of valve.

Packaging Pocket 7

- Spring

Step 8 Replace OE Line Pressure Accumulator Piston & Springs

Place O-rings into shallow grooves on pistons. Lubricate with Sonnax slippery stick O-LUBE. Roll on bench to size. Install piston with open end facing outboard. Then install large spring followed by small spring.

Packaging Pocket 8

- Accumulator Piston
- O-Rings (3) 1 extra
- Spring, Large
- Spring, Small

Step 9 Replace OE Secondary Regulator Valve & Spring

Place scarf-cut seal into shallow groove on valve. Rolling the seal into a smaller diameter before placing the seal in the groove will help to keep the seal surface below the valve diameter, allowing for easier installation. Install valve into bore, seal end first, followed by the spring.

NOTE: Due to the design changes on the Sonnax valve, vacuum testing at the two inboard ports is not a valid sealing test. The Sonnax valve requires balance fluid to travel through the valve and push the seal outward to conform to the worn bore.

Packaging Pocket 9

- Valve
- Seals (2) 1 extra
- Spring

Step 10 Replace OE Lockup Control Valve Assembly

Packaging Pocket 10

- Valve
- Sleeve

NOTE: Re-use OE spring.

Step 11 Replace OE Springs

Packaging Pocket 11

- 11A.** Line Relief Spring, Red
- 11B.** B4 Release & Reverse Inhibit Small Springs (2), No color
NOTE: These are not used in all castings.
- 11C.** TCC Check Valve Spring, Yellow
- 11D.** Cooler Bypass Spring, Large, No color
- 11E.** TCC Check Valve Spring, White



AW55-50SN, AW55-51SN, AF23/33, RE5F22A ZIP KIT®

PART NUMBER **AW55-50SN-ZIP**

INSTALLATION & TESTING BOOKLET

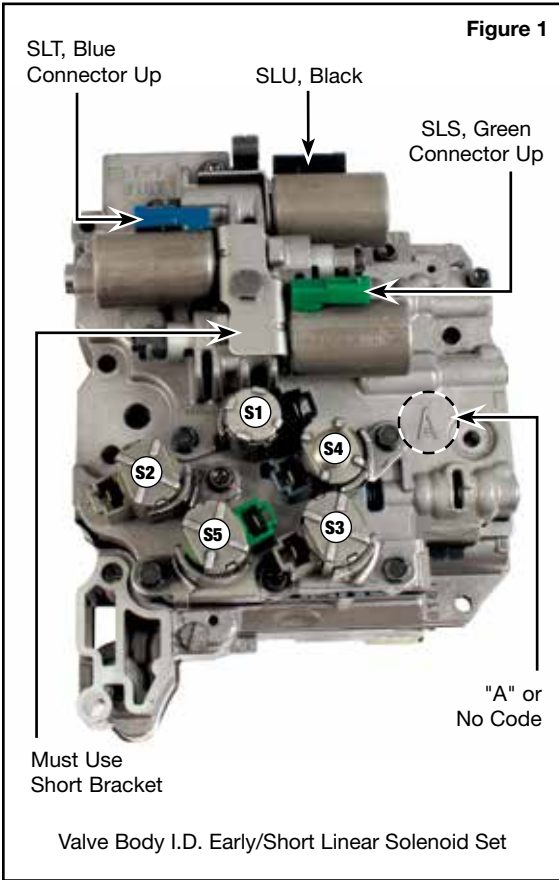

IMPORTANT NOTE: The AW55-50SN/51SN, AF23/33, RE5F22A transmission is used in GM, Volvo, Saturn, Saab, Opel and Renault vehicles. What is a normal operating condition for one vehicle may not be for another due to the differences in operating modes and shift strategies used by the various manufacturers. The OE specifications given in this booklet are for GM units. Check OE information specific for your application during rebuild.

Electronic Cautions

Reflashing

The TCM (transmission control module) has memorized values that aid in shift control. Most of the manufacturers have upgrades for this application. Check OE bulletins and with your local dealers to ensure the latest updates have been performed for your application.

Shift Adaptations

This transmission uses adaptive strategy to adjust the various shift feels. After valve body work, these shift adaptations must be cleared and relearned or shift feel complaints and reduced transmission life can occur. The different manufacturers use different relearn procedures. Check OE specifications to ensure proper relearn for your application.

Solenoids

This unit uses 3 linear solenoids (SLU, SLT and SLS) calibrated to the valve body that are critical to shift feel (Figure 1). These solenoids overlap electronically and hydraulically which makes diagnosis difficult. Additional technical and rebuild/replace information is included on pages 2 – 4. This transmission also uses 5 on/off style solenoids used to control the position of the shift valves. All solenoids should be cleaned to remove debris that results in sticking and malfunction.

Apply Component Chart

Figure 2

Range	Gear	SOL S1	SOL S2	SOL S3	SOL S4	SOL S5	Second Clutch (B2)	Coast Clutch (B1)	Second Sprag (F1)	Low Sprag (F2)	Low/Rev Clutch (B3)	FWD Clutch (C1)	Direct Clutch (C2)	4-5 Clutch (C3)	3rd Band (B4)	1-2/Rev Clutch (B5)
Park	P	Off	Off	Off	Off	Off										Applied
Reverse	R	Off*	Off	On*	Off	On*					Applied		Applied			Applied
Neutral	N	Off	Off	Off	Off	Off										Applied
Drive	1	On	Off	On	Off	Off				Hold		Applied				Applied
	2	Off	On	On	Off	Off	Applied	Applied	Hold			Applied				Applied
	3	Off	On	On	On	Off	Applied	Applied	Hold			Applied			Applied	
	4	Off	On	Off	On	Off	Applied	Applied	Hold			Applied		Applied		
	5	Off	Off	Off	On	Off	Applied					Applied	Applied	Applied		
Intern	Limp	Off	Off	Off	Off	Off	Applied					Applied	Applied	Applied		
	1	On	Off	On	Off	Off				Hold		Applied				Applied
	2	Off	On	On	Off	Off	Applied	Applied	Hold			Applied				Applied
Low	3	Off	On	On	On	Off	Applied	Applied	Hold			Applied			Applied	
	1 E/B	On	Off	On	Off	On				Hold	Applied	Applied				Applied
	2	Off	On	On	Off	Off	Applied	Applied	Hold			Applied				Applied

* If vehicle speed is above 7 km/h (4 mph), the TCM commands the shift solenoids to inhibit reverse

Solenoids

On/Off Shift Solenoids

The chart provides resistances for checking solenoids, function to aid in diagnosis, and connector and wire color to ensure proper assembly.

Linear (SLU, SLS, SLT) Solenoids

Handle these solenoids with care. Inadvertent turning of the adjuster at the end of the solenoid will affect pressure control and cause shift complaints. It is also common for these solenoids to crack at the casting neck flange area or connectors due to rough shipping and handling. Examine the solenoids first to ensure they are not cracked or otherwise damaged and are free of debris.

Linear Solenoid Installation

The length of the SLT and SLS solenoid snouts have changed, as well as the retaining bracket and installation orientation of the connectors. The SLU remains the same for all valve bodies. Proper matching of parts and correct installation is necessary to avoid shift complaints (Figures 1, 3-7).

No Code & A Code Castings

SLT and SLS: Connector faces up (away from 5 on/off solenoid) when properly installed (Figure 1).

- If short SLS and SLT solenoids (1.408" w/hole) are used, an early style bracket must be used (Figures 5 & 6).
- If long SLS and SLT solenoids (1.510" w/slot) are used, a late style bracket must be used (Figures 5 & 6).

B & C Code Castings

SLT & SLS: Connector faces down (toward the 5 on/off solenoid) when properly installed (Figure 4).

- Must use long solenoid (1.510" w/slot) (Figure 6)
- Must use late bracket (Figure 5)

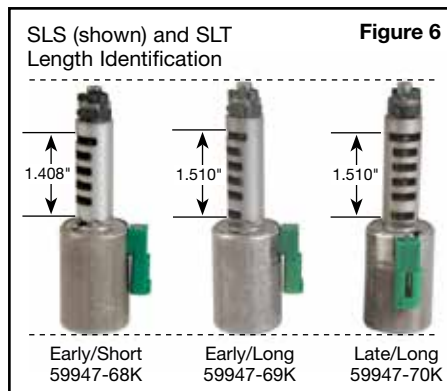
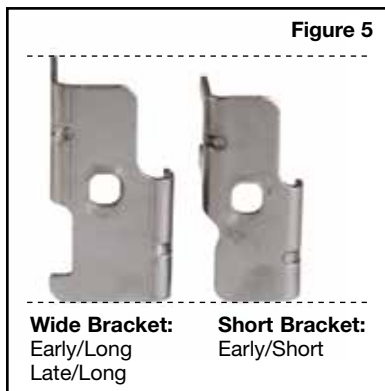

Solenoid Apply Chart

Figure 3

Solenoid	Connector	Wire Color (s)	Flow	Resistance	Function
SLU	Black	Green/Brown	N.C.	5.0 - 5.6 ohms at 68"	TCC apply, reverse 1-2, 2-3 up/down shift
SLT	Blue	Green/Gray	N.O.	5.0 - 5.6 ohms at 68"	Line rise, engagements, converter pressure
SLS	Green	Blue/Red	N.O.	5.0 - 5.6 ohms at 68"	Clutch pressure, shift quality
S1	Black	White	N.O.	13.5 - 15.5 ohms at 68"	1st, 1-2 shift, reverse
S2	Black/Gray	Black	N.O. - GM N.C. - Volvo	13.5 - 15.5 ohms at 68"	2nd, 3rd, 4-5 shift
S3	Gray	Yellow	N.C.	13.5 - 15.5 ohms at 68"	Reverse, 3-4 shift fwd engagement
S4	Blue/Green	Purple/Red	N.O.	13.5 - 15.5 ohms at 68"	3, 4, 5, 2-3 shift
S5	Green/Red/Gray	Blue/Black - '02 Volvo	N.C.	13.5 - 15.5 ohms at 68"	Reverse engagement

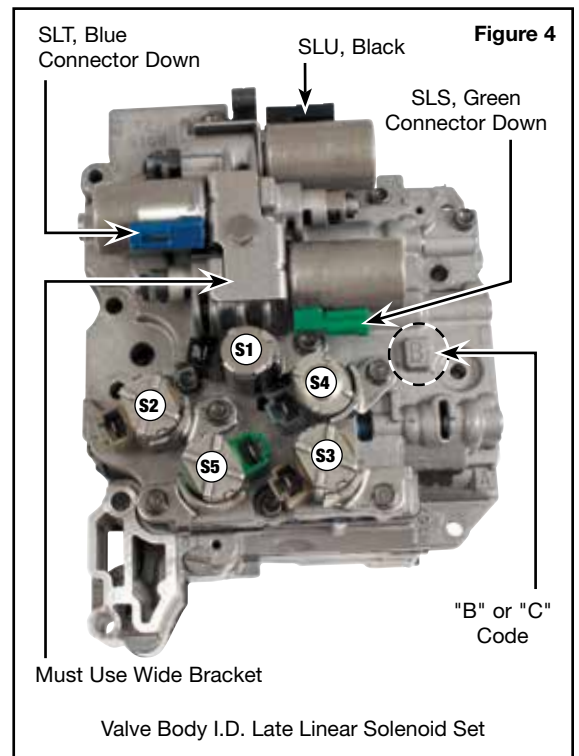

Linear Solenoid Strategy

Gear	SLU	SLT	SLS
Park/Drive		X	
Park/Reverse		X	X
1-2, 2-1	X		
2-3	X	X	
3-2	X		X
3-4, 4-3	TC		X
4-5, 5-4	TC		X
TCC	X		
All Up & Downshifts		X	X

Key: X = Greatest effect of this solenoid on shift indicated.
TC = Drivability effect on converter clutch.

Figure 8

Important Solenoid Port Check

Always double-check that the solenoid ports mate radially to the ports in the valve body casting.

Linear Solenoid Adjustment

The adjustment screws on the end of the solenoids set the spring force against the valve. The spring opposes the force of the solenoid coil. To avoid severe drivability issues, the adjuster should be set at or near the OE position, which averages .195" (Figure 7) measured from the end of the adjuster to the end of the solenoid manifold. If the adjustment is too far off (either in or out) a variety of drivability issues occur. In many instances, an out-of-adjustment solenoid may cause the TCM to set a gear ratio code or a solenoid amperage high/low code. Turning the SLT adjuster counter-clockwise reduces SLT pressure, which will lower line and converter pressure. Turning the SLS adjuster counter-clockwise reduces SLS pressure, which will reduce clutch apply pressures. The charts in

Figure 9

Solenoid Adjustments

Solenoid	Adjust Inward (CW)	Adjust Outward (CCW)
SLT Line Rise Solenoid Blue Connector	Increase SLT pressure if: <ul style="list-style-type: none"> Neutral-to-Drive delay Long shifts Low cooler flow 	Decrease SLT pressure if: <ul style="list-style-type: none"> Long 2-3 shift due to clutch overlap (2-3 Bind-up) 3-2 Coastdown bump Harsh forward engagement Harsh TCC apply Loss of lube or cooler flow
SLS Shift Pressure Solenoid Green Connector	Increase SLS pressure if: <ul style="list-style-type: none"> Soft upshifts Low speed 2-3 flare Slight RPM flare on 3-4, 4-5 shifts 	Decrease SLS pressure if: <ul style="list-style-type: none"> Harsh reverse Harsh 1-2 shift Harsh 2-3 shift with end bump Loss of TCC apply High C1 clutch pressure 3-2 Shift flare/bang
SLU Lockup Solenoid Black Connector	Decrease SLU pressure if: <ul style="list-style-type: none"> Soft shifts Early TCC apply No TCC lockup 	Increase SLU pressure if: <ul style="list-style-type: none"> Hard 1-2, 2-1 shift Firm/Late TCC apply

Figures 8 & 9 are for reference on which solenoids to adjust and in what direction, should tuning be required.

Heat Testing Linear Solenoids

A common issue found with the linear solenoids is a hot drivability concern. This happens when the plunger starts to seize within the coil bushings at operating temperature. The results are acceptable shifts when cool, but a harsh downshift or flare upshift (often 3-2 and 2-3) over the 215°F range. If you suspect this, a slow or sticking linear solenoid can be identified by a hot soak test. Heat the solenoid to operating temperature. Using a shop rag or some method of protecting your hand from the heat, pry and hold the valve away from the plunger (with a pick or small screwdriver through casting slot) and shake the solenoid. In a good solenoid, the plunger shaft will be free to rattle back and forth (Figures 10 & 11).



Figure 10

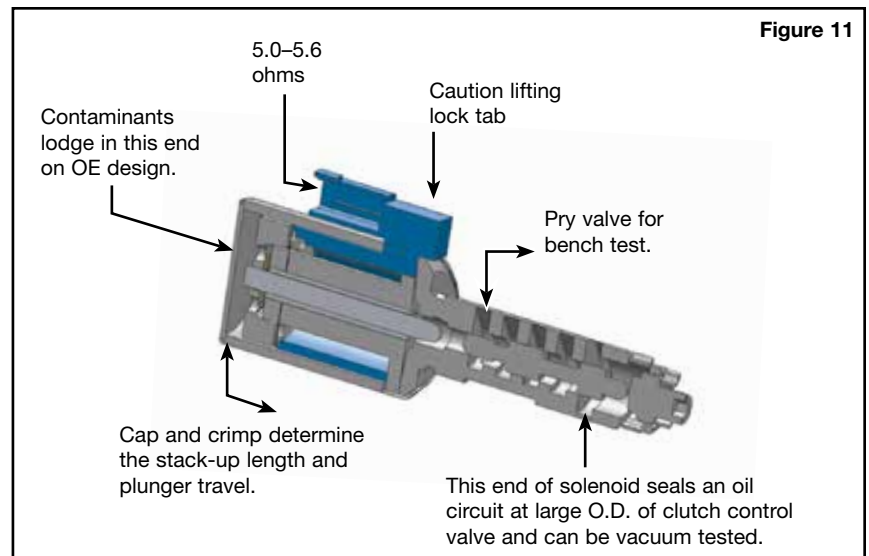

Figure 11

Solenoid Replacements

Aisin AW 55-50SN, 55-51SN, AF23/33 and RE5F22A linear solenoids are used to control line rise (SLT), the converter clutch (SLU) and the oil flow rate and accumulation for the clutch circuits (SLS). The flow-to and function of these solenoids overlap, making diagnosis difficult. The solenoids are prone to sticking of the internal pintle, creating inconsistent movement of the solenoid valves. Shift complaints and pressure/flow related issues result. Remanufactured linear solenoid kits (set of three solenoids) from Sonnax (Figure 12) were developed with an exclusive Sonnax process that eliminates sticking solenoid problems. These solenoids are 100% tested for pressure curve performance on a valve body test stand and calibrated to OE specifications. Readjustment should not be required if the valve body leakage has been addressed and a relearn process completed.



Remanufactured Linear Solenoid Kits

Sonnax Part Number	Kit Style
59947-68K	Early/Short
59947-69K	Early/Long
59947-70K	Late/Long

Caution: Ensure correct style of SLS/SLT solenoid, based on connector direction and bracket design (Figures 1, 4 – 6).

Casting & Plate Combinations

There are various castings and plates that must be properly matched to ensure correct function. The front control valve body (Figure 13) may have an exhaust hole that will correlate to the need for a check valve & spring on the opposite side (Figure 14). Castings with this exhaust hole must be matched with a middle control casting with 2 flags (Figure 15) and a rear control plate with the two noted orifices.

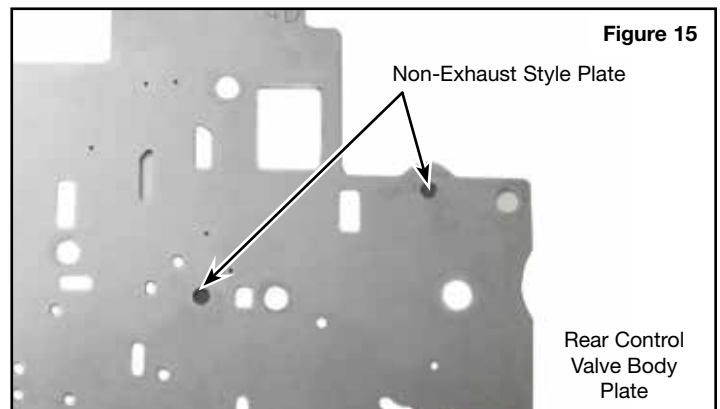
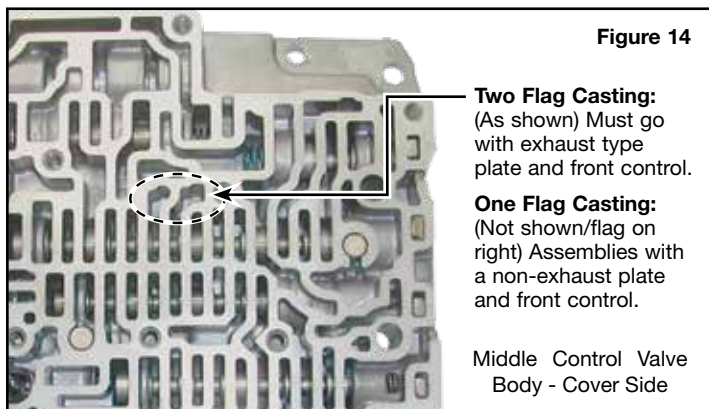
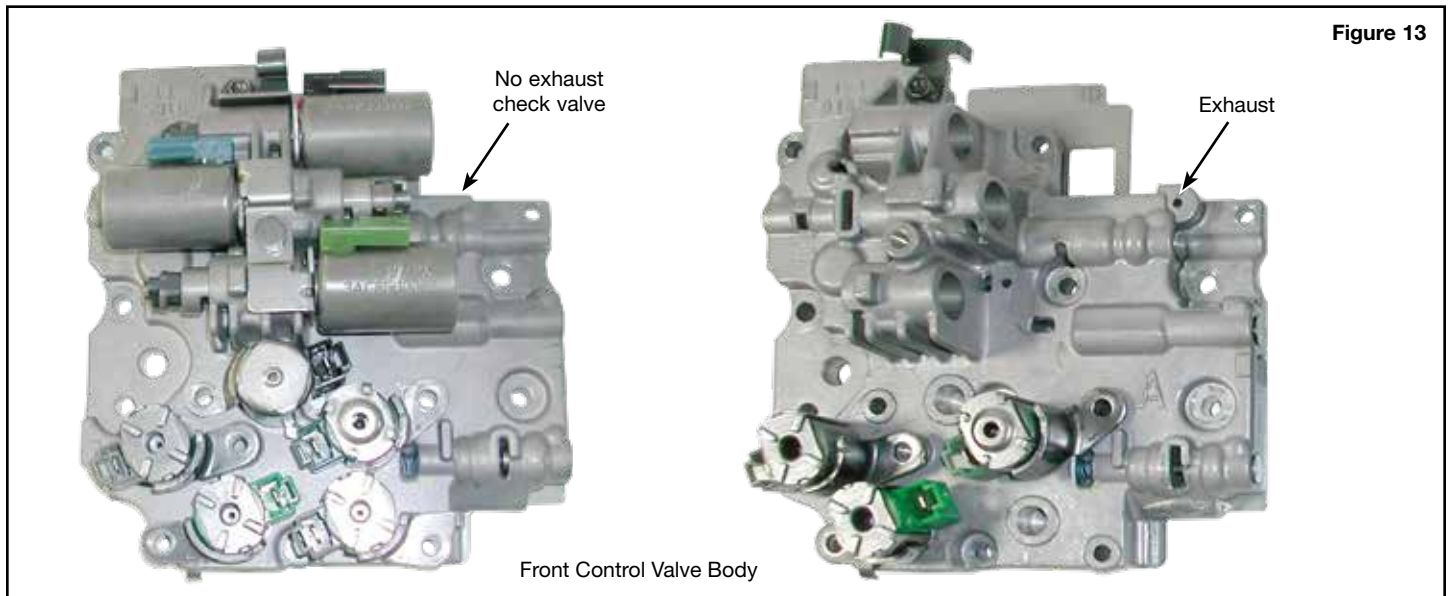

Critical Wear Areas & Vacuum Test Locations



NOTE: OE valves are shown in rest position and should be tested in rest position unless otherwise indicated. Test locations are pointed to with an arrow. Springs are not shown for visual clarity. Low vacuum reading indicates wear and Sonnax parts noted for replacement. For specific vacuum test information, refer to individual part instructions included in kits and available at www.sonnax.com.

AW55-50SN Valve Body

Neutral Relay Valve

- Delayed Forward
- Increased throttle required for engagement

Replace with Sonnax Part No. **59947-35K**

Requires F-59947-TL34 & VB-FIX

Front Control Valve Body (No exhaust style)

Solenoid Modulator Valve

- Low line pressure
- 2-3 Flare
- No 3rd, 4th or 5th
- Delayed Forward
- 5th Gear only
- No lockup

Replace with Sonnax Part No. **59947-34K**

Requires F-59947-TL34 & VB-FIX

Solenoid Relay Valve & Plunger/Sleeve Assembly

- No lockup
- Shift concerns
- Engine stall on engagement
- 2-3 Flare
- No 2-3
- Harsh shifts
- B5 Clutch distress

Replace with Sonnax Part No. **59947-05K**

3rd Gear Band (B4) Release Valve

- 2-3 Flare
- 2-3 Neutral
- 3-2 Harsh
- 3-2 Neutral

Replace with Sonnax Part No. **59947-26K**

Requires F-59947-TL26 & VB-FIX

Seal the port on the opposite side of casting when testing these locations.

Main Pressure Regulator Valve & Boost Valve Assembly

- Soft shifts
- Delayed/Harsh shifts
- Delayed engagement
- TCC apply & release concerns

Replace with Sonnax Part No. **59947-07K or 59947-12K**

59947-12K Requires F-59947-TL12 & VB-FIX

Middle Control Valve Body (Cover side)

Middle Control Valve Body (Rear side)

Critical Wear Areas & Vacuum Test Locations

NOTE: OE valves are shown in rest position and should be tested in rest position unless otherwise indicated. Test locations are pointed to with an arrow. Springs are not shown for visual clarity. Low vacuum reading indicates wear and Sonnax parts noted for replacement. For specific vacuum test information, refer to individual part instructions included in kits and available at www.sonnax.com.

AW55-50SN Valve Body • Rear Control (Back, Front and Side views)

Shift Pressure Control Valve

- 2-3, 3-4, 4-5 Harsh
- No 5th
- Low Reverse pressure
- B1, B2, C2 Clutch burned
- High line pressure in Reverse

Replace with Sonnax Part No. 59947-38K

Shift Pressure Control Plunger Valve

- 2-3 Quality poor • 3-4, 4-5 Harsh • High line pressure
- B1, B2, C2 Clutch burned • Low Reverse pressure

Replace with Sonnax Part No. 59947-75K

M2 Shift Valve

- No Reverse
- No Neutral control
- No 1st, 2nd, 3rd & 4th

Shift Pressure Relay Valve

- Slips in Reverse
- No engine braking in 2nd, 3rd & 4th

Line Pressure Control (SLT) Accumulator Assembly

- Low line pressure
- Delayed Forward
- Harsh shifts
- 2-3 Flare
- Erratic SLT pressure

Replace with Sonnax Part No. 59947-LPC

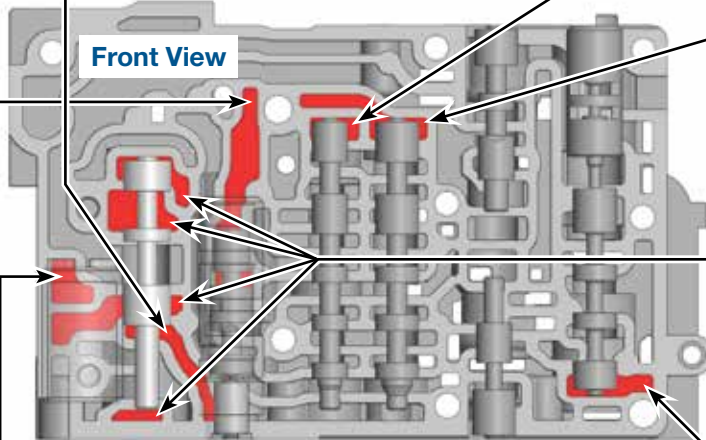

Secondary Regulator Valve

- TCC slip/surge
- Overheated fluid, bushings & converter
- Poor shift quality
- Harsh Reverse
- Low lube oil flow
- Bushing failure

Replace with Sonnax Part No. 59947-16K
Requires F-59947-TL16 & VB-FIX

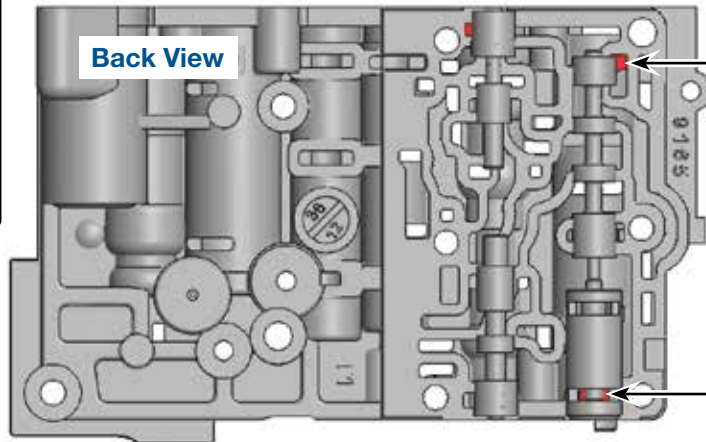

Lockup Relay Valve

- TCC apply & release concerns
- Inadequate lubrication
- TCC codes

Replace with Sonnax Part No. 59947-01K or 59947-77K
59947-77K Requires F-97741-TL20 & VB-FIX

Seal the port on the opposite side of casting when testing these locations.

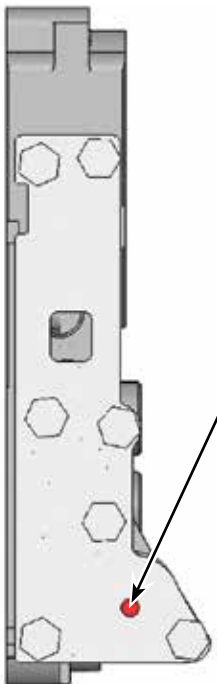

Lockup Control Valve & Sleeve/Plunger Assembly

- TCC apply & release concerns
- Burnt converter
- TCC codes

Replace with Sonnax Part No. 59947-03K or 59947-29K
59947-29K Requires F-59947-TL29, F-15741-TL29PL & VB-FIX

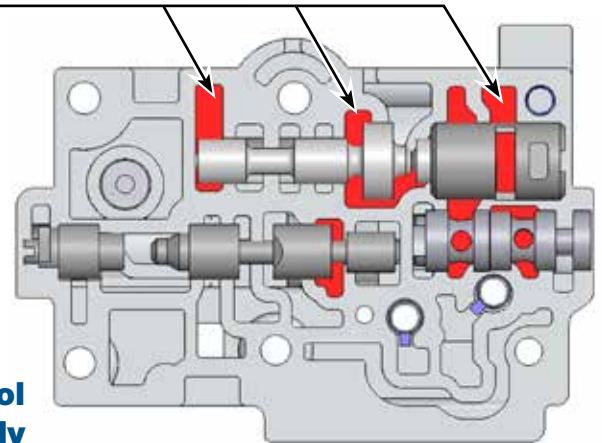

No. 2 Rear Control Valve Body

OE Exploded View

Front & Middle Control Valve Body • AW55-50SN Valve Body Shown Here

NOTE: Depending upon vehicle application, the OE springs shown may not be present.

Front Control Valve Body
(No-exhaust style)

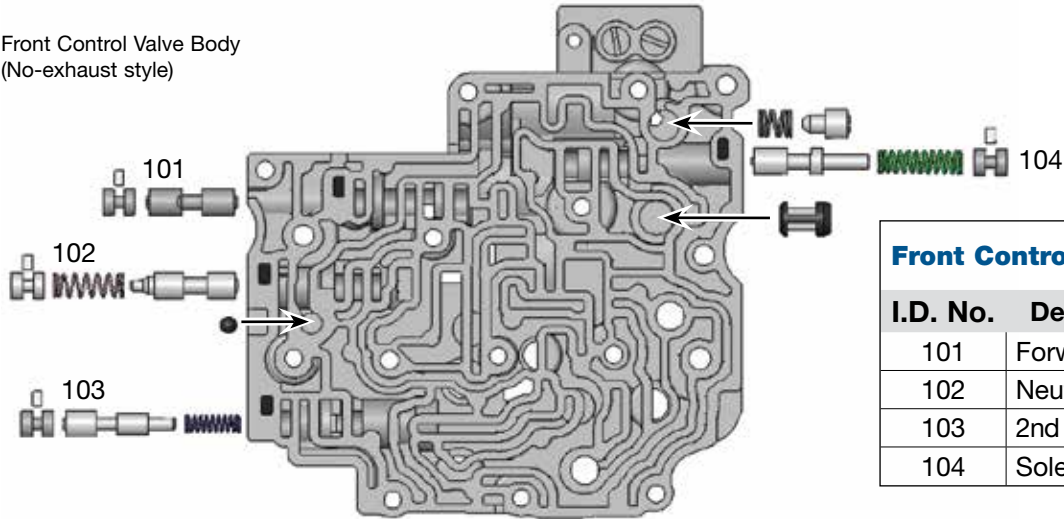

Front Control Valve Body Descriptions

I.D. No.	Description
101	Forward Clutch (C1) Control Valve
102	Neutral Relay Valve
103	2nd Coast Clutch (B1) Control Valve
104	Solenoid Modulator Valve

Middle Control Valve Body
(Cover side)

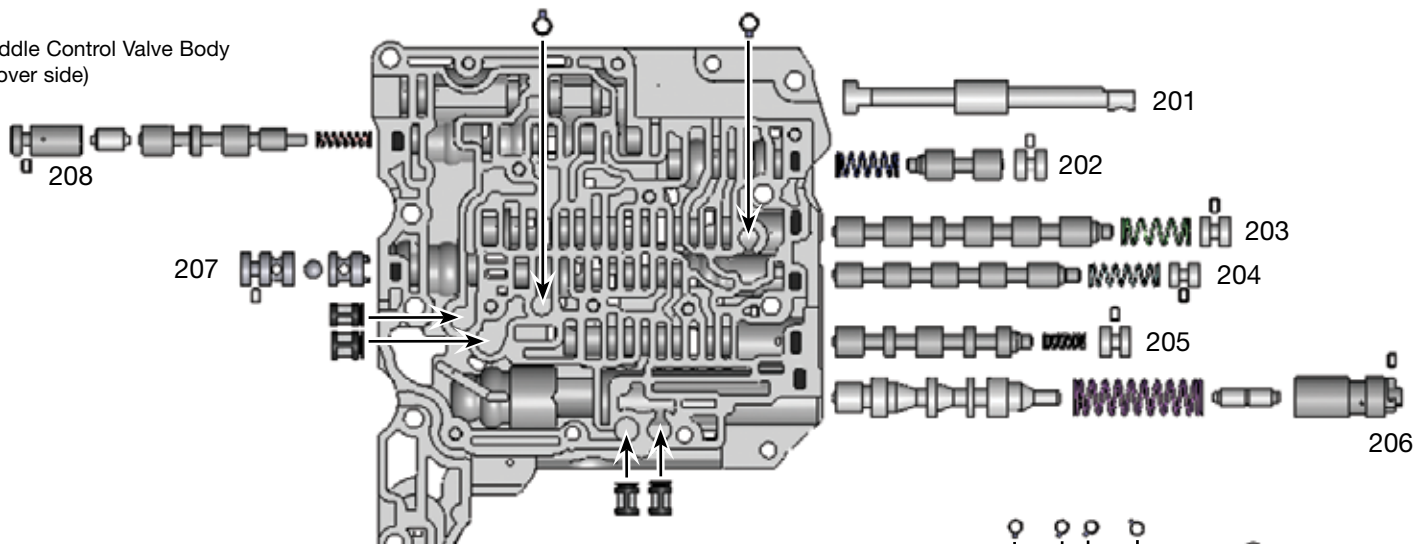

Middle Control Valve Body Descriptions

I.D. No.	Description
201	Manual Valve
202	3rd Gear Band (B4) Release Valve
203	U1 Shift Valve
204	M1 Shift Valve
205	U2 Shift Valve
206	Primary Regulator Valve & Plunger Valve Assembly
207	Reverse Shift Ball Check Valve
208	Solenoid Relay Valve & Plunger Valve Assembly

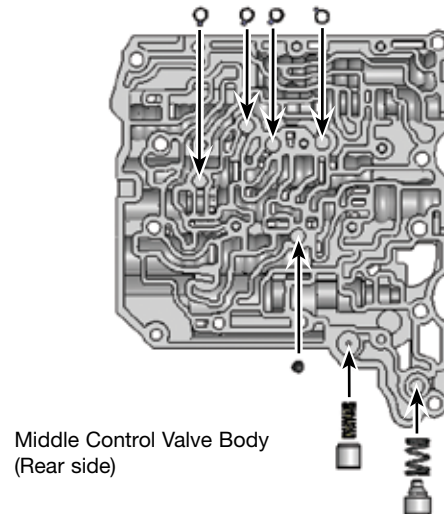

Middle Control Valve Body
(Rear side)

OE Exploded View

Rear & No. 2 Rear Control Valve Body • AW55-50SN Valve Body Shown Here

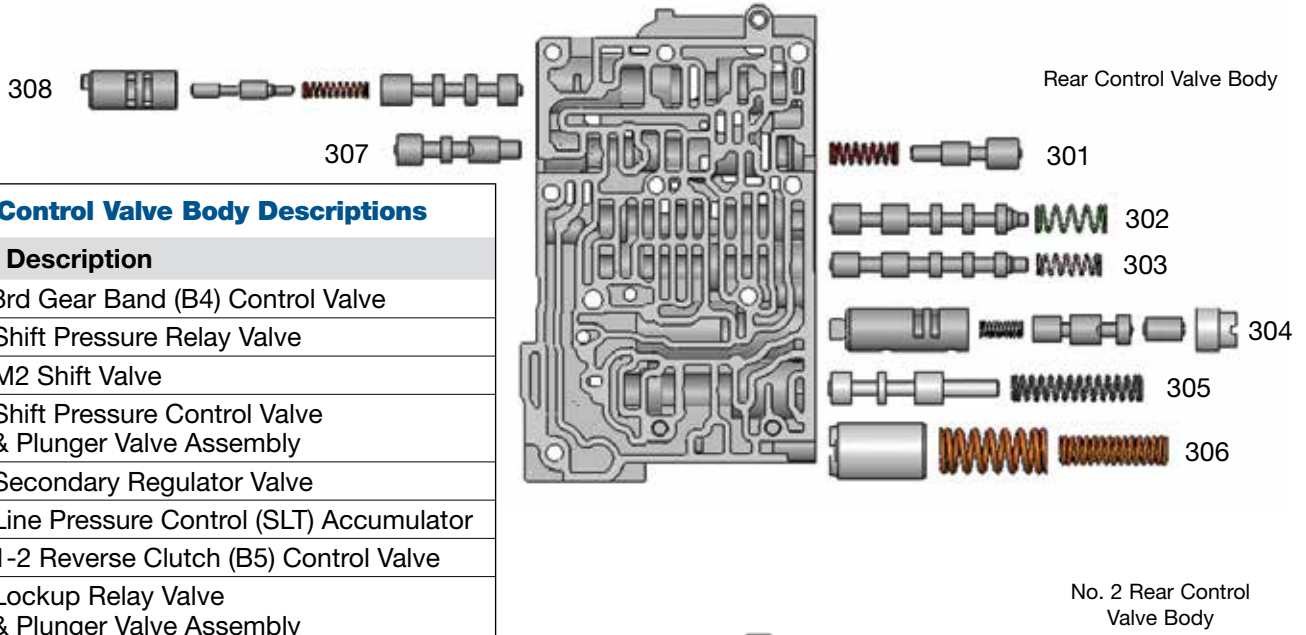

Rear Control Valve Body Descriptions	
I.D. No.	Description
301	3rd Gear Band (B4) Control Valve
302	Shift Pressure Relay Valve
303	M2 Shift Valve
304	Shift Pressure Control Valve & Plunger Valve Assembly
305	Secondary Regulator Valve
306	Line Pressure Control (SLT) Accumulator
307	1-2 Reverse Clutch (B5) Control Valve
308	Lockup Relay Valve & Plunger Valve Assembly

No. 2 Rear Control Valve Body Descriptions	
I.D. No.	Description
401	Lockup Control Valve & Plunger Valve Assembly
402	Reverse Shift Restrict Ball Check Valve
403	2nd Clutch (B2) Control Valve

Bolt Locations

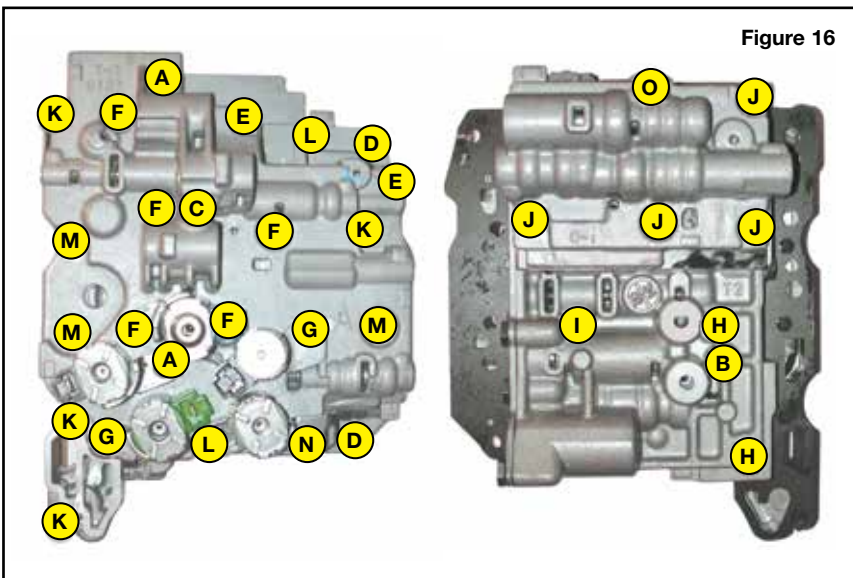

Torque Specification Chart Figure 17

Bolt ID	Length (mm)	Torque (in-lb)	No. Bolts Required
A	10	62	2
B	12	62	1
C	13	62	1
D	16	89	2
E	16	62	2
F	20	62	5
G	28	62	2
H	35	62	2
I	40	62	1
J	49.5	62	4
K	50	89	4
L	50	62	2
M	55	62	3
N	62	62	1
O	76	62	1