

**Aisin AW TF-60SN; Mini 6F21WA;
VW/Audi 09G, 09K, 09M**

**Oversized K2
Clutch Control
Valve Kit**

Part No.
15741-57K

- Valve
- Spring



Tool Kit

Part No.
F-15741-TL57

- Reamer
- Reamer Jig
- Guide Pin

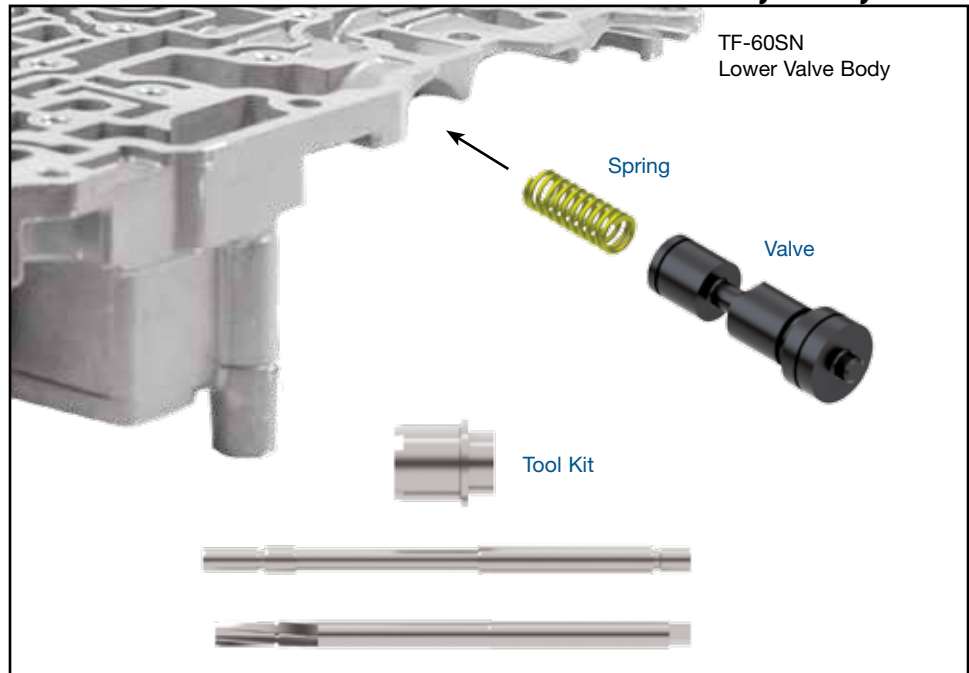

NOTE: Sonnax “F-Tool” kits designed to service a specific bore require the VB-FIX, a self-aligning valve body reaming fixture. More information and instructions can be found online at www.sonnax.com.



CAUTION: Prior to removal of spring adjustment plug, measure and record the distance from the plug to the casting (**Figure 1**). This dimension must be matched during reassembly.

1. Disassembly

- Remove and save OE adjustment plug retaining clip.
- Measure and record adjustment plug-to-casting distance, then remove and save OE adjustment plug.
- Remove OE retaining pin and solenoid, set aside for re-use.
- Remove and discard OE valve and spring.

2. Bore Reaming

Ream K2 clutch control valve bore (for reaming instructions/reamer care, please visit www.sonnax.com). Sonnax reaming tool kit **F-15741-TL57** and **VB-FIX** are required for this operation.



3. Installation & Assembly

- Be certain all debris has been removed from valve bore and body.
- Reinstall OE spring adjustment plug and set to the reference dimension noted in disassembly procedure, then reinstall OE adjustment plug retaining clip.

 **NOTE:** To reduce pressure loss past the spring adjustment plug threads, an ATF-compatible thread sealant can be used. Permatex® 24163 surface prep activator combined with blue Threadlocker works well for this purpose. Compound used must not create a permanent set.

- Install Sonnax spring, followed by Sonnax valve; ensure spring is secured in spring pocket during installation.
- Reinstall OE solenoid and retaining pin.

4. Final Testing

Vacuum tests at the ports indicated hold the recommended minimum 18 in-Hg (**Figure 2**).

