

## Oversized C3 Clutch Control Valve Kit

**Part No.**  
**39741-50K**



- Valve
- Spring

**NOTE:** Volvo (AM6), Opel (AF40), Peugeot (TF-80), Saab (AF40/6), Land Rover (TF-80), Ford (AF21) and Mazda (AW6A-EL).

## Tool Kit



**Part No.**  
**F-39741-TL50**

- Reamer
- Reamer Jig
- Guide Pin

**NOTE:** Sonnax “F-Tool” kits designed to service a specific bore require the VB-FIX, a self-aligning valve body reaming fixture. More information and instructions can be found online at [www.sonnax.com](http://www.sonnax.com).

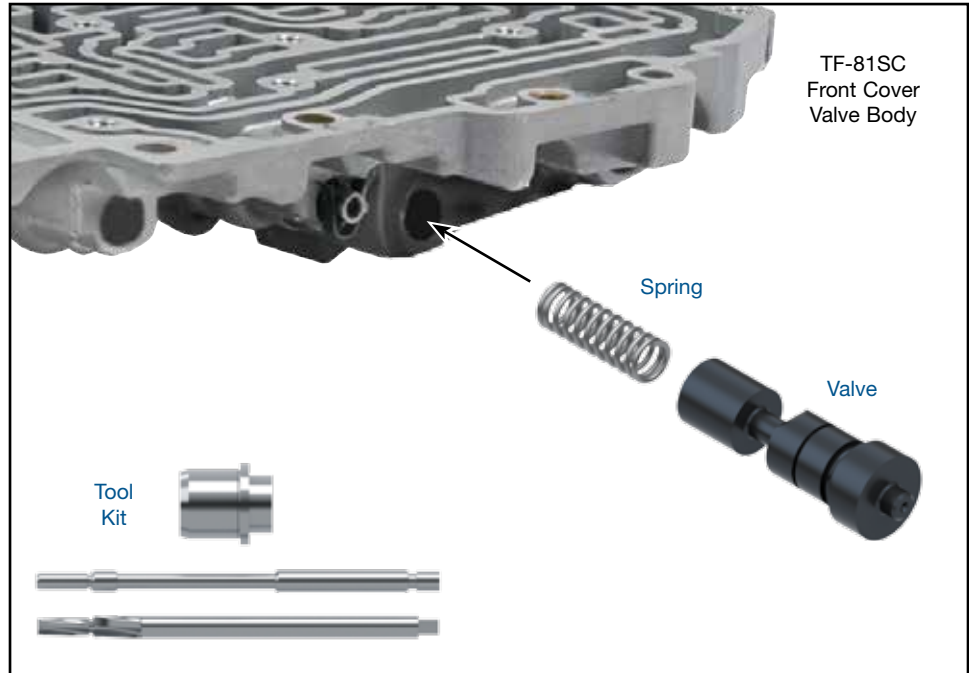

**CAUTION:** Prior to removal of spring adjustment plug, measure and record distance from end of plug to the casting (**Figure 1**). This dimension must be matched during reassembly.

### 1. Disassembly

- Remove and save OE adjustment plug retaining clip.
- Measure and record adjustment plug-to-casting distance, then remove and save OE adjustment plug (**Figure 1**).
- Remove OE retaining pin and solenoid, set aside for reuse.
- Remove and discard OE valve and spring.

### 2. Bore Reaming

Ream C3 clutch control valve bore (for reaming instructions/reamer care, please visit [www.sonnax.com](http://www.sonnax.com)). Sonnax reaming tool kit **F-39741-TL50** and **VB-FIX** are required for this operation.

### 3. Installation & Assembly

- Be certain all debris has been removed from the valve bore and valve body.
- Reinstall OE spring adjustment plug and set to reference dimension noted in disassembly procedure, then reinstall OE adjustment plug retaining clip.



Location shown may not match your particular application; picture is to illustrate measuring procedure only.

### 3. Installation & Assembly (continued)

 **NOTE:** To reduce pressure loss past spring adjustment plug threads, an ATF-compatible thread sealant can be used. Permatex® 24163 surface prep activator combined with blue thread locker works well for this purpose. Compound used must not create a permanent set.

- c. Install Sonnax spring, followed by Sonnax valve; ensure spring is seated in valve spring pocket during installation.
- d. Reinstall OE solenoid and retaining pin.

### 4. Final Testing

Vacuum testing at the port(s) indicated holds the recommended minimum 18 in-Hg (**Figure 2**).

