

4F27E Remanufactured Valve Body

Part Nos.

F020

FN4A-EL Remanufactured Valve Body

Part Nos.

F021

NOTE: Save your existing manual valve for reuse with our remanufactured valve body.

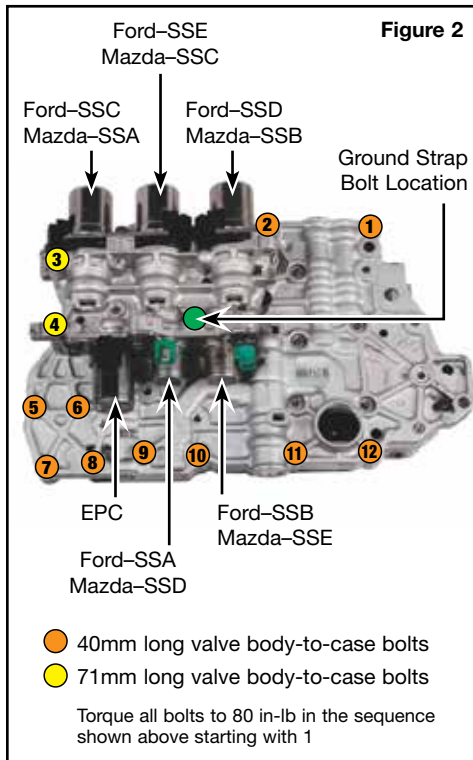

Valve Body Installation Tips

1. Verify Case

- Verify two rubber seals are installed on the top of the valve body. Verify accumulator springs and pistons are installed into case correctly (**Figure 1**). Install valve body onto transmission case while indexing the manual valve link into the manual linkage.
- Install the 13 valve body-to-case bolts in the noted locations (**Figure 2**).

Torque them in the sequence shown, this can help prevent valve bind-up.

- See ground strap location (**Figure 2**) and refer to chart (**Figure 3**) for connector color and wire color identification as the internal wire harness connectors can be incorrectly installed.

NOTE: The green circle is the location for the ground strap from the wiring harness.

2. Fluid Fill and Road Test

- Fill the transmission to factory spec with OE compatible ATF.
- Let engine run to help warm transmission fluid to 185°.
- Install capable scan tool to reset transmission adaptives by resetting "Keep Alive Memory".
- Road test vehicle performing 10-15 upshift and downshift cycles thru all four speeds.



NOTE: Downshift clunks can be common during the relearn. This condition will typically resolve itself within the 10-15 shift cycles.

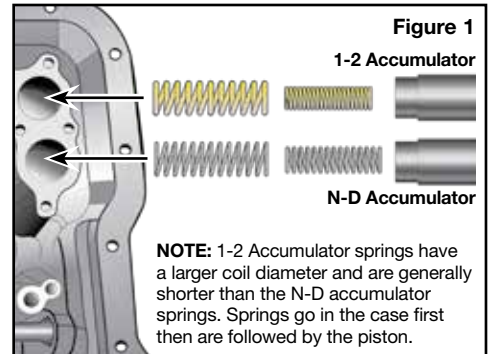

3. Bonus Diagnostic Tech

This Sonnax remanufactured valve body has been through a rigorous inspection and rebuild process, and then put through a comprehensive functional hydraulic and electronic test to ensure it meets OE performance and quality. It is designed to eliminate many pressure, shift, and converter related complaints, but will not correct complaints that stem from other areas of the transmission. Following are common areas of failure or root causes for symptoms that could be attributed to valve body issues that should also be examined or addressed during your transmission build. In addition, see air test locations (Figures 4 & 5) to verify internal integrity, and a component application chart for troubleshooting drivability issues.

4. Common Failure Areas

- a. Forward engagement problems and 4-3 flares and torque converter slip codes can be attributed to worn stator bushings. Bushings should be checked and replaced.
- b. A 2-3 flare can be attributed to wear in the case between the servo pin and the bore. In addition the direct clutch and the sealing ring tower in the rear of the case can cause the same issue.
- c. A 1-3 shift can be caused by installing the solenoid connectors backwards.

Solenoid Resistance Chart & Wire Harness Information

Figure 3

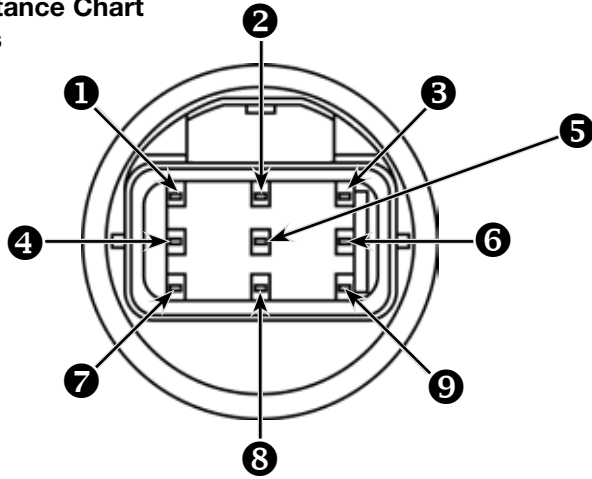

Terminals	Solenoid	Ohms Resistance at 20° C (70° F)	Harness Connector Color	Common Wire Color(s)
6 & Gnd.	Shift Solenoid "A" (On-Off)	10.9 – 26.2	Clear	White
8 & Gnd.	Shift Solenoid "B" (On-Off)	10.9 – 26.2	Black	Red
3 & Gnd.	Shift Solenoid "C" (PWM)	1.0 – 4.2	White	Blue/Green
9 & Gnd.	Shift Solenoid "D" (PWM)	1.0 – 4.2	Blue	Blue/Brown
1 & Gnd.	Shift Solenoid "E" (PWM)	1.0 – 4.2	Green	Black/Green
2 & 7	EPC Solenoid (PWM)	2.4 – 7.3	Black	Orange/Blue

NOTE: When ohm testing solenoids, ground meter to valve body or case.

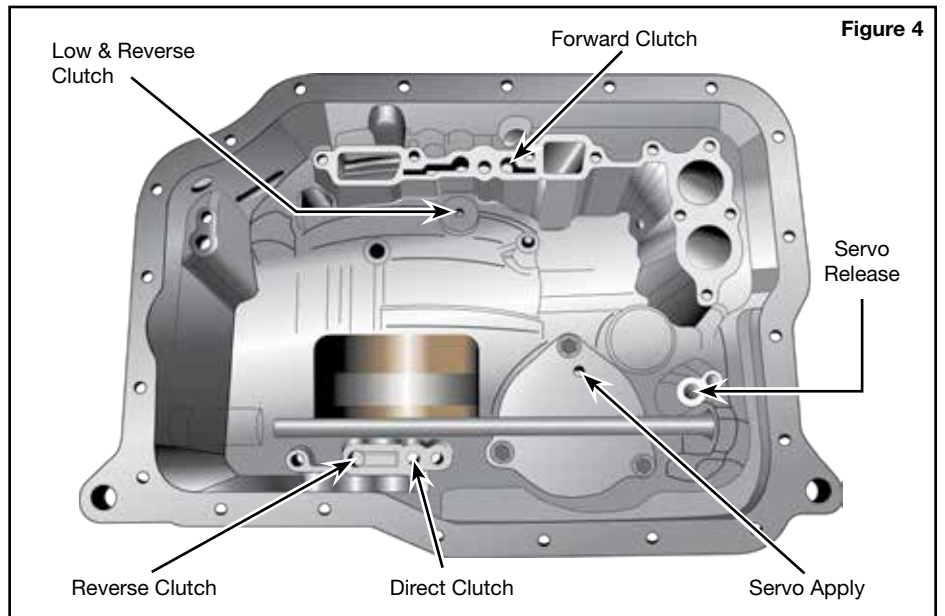

Figure 4

4F27E/FN4A-EL Application Chart

Figure 5

Gear Range	Forward Clutch	2-4 Brake	Direct Clutch	Reverse Clutch	Low/Rev Clutch	Low One Way Clutch
Park						
Reverse				ON	ON	
Neutral						
D-1st Gear	ON					ON
D-2nd Gear	ON	ON				
D-3rd Gear	ON		ON			
D-4th Gear		ON	ON			