

GM Powerglide

Stator Tube Kit

Part No.

28154S-07K

- Stator Tube
- Bushings (2)

NOTE: For use with ringless style input shafts with .998" journal diameter.



NOTE: Requires pump to be machined.



1. Pump Cover Machining

- With original stator tube removed, drill converter feed passage to .156" (5/32") (Figure 1). If already larger, that is alright.
- Machine pump cover per dimensions (Figure 2).

2. Stator Tube Installation

- Inspect pump cover internal passages for high clutch feed, converter return and cooler return/lube. To ensure adequate oil flow it may be necessary to enlarge internal passages with a die grinder.
- Align two holes in stator tube with center of converter return passage and center of cooler return/lube passage in pump cover.
- Press stator tube into pump cover so that front end of serrations are just flush with recess on pump cover (Figure 1).

3. Stator Tube Installation



NOTE: Included stator tube bushings are common .500" wide THM 400 front stator tube bushings. Depending on shaft being used and other assembly variables, it may help to machine the bushings to .400" width to ensure oil feed hole in shaft is not restricted.

- Install first bushing into rear of stator tube until lightly seated against shoulder in stator tube bore.
- Install second bushing to a depth of .015" from rear end of stator tube. Bushing may not be entirely past bore chamfer.
- Check fit of bushings with shaft.

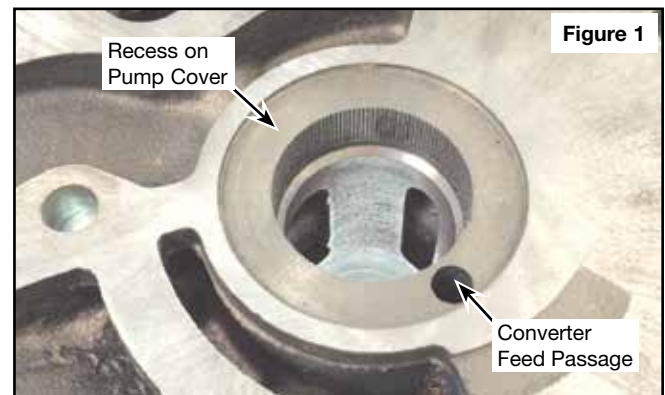

Figure 1

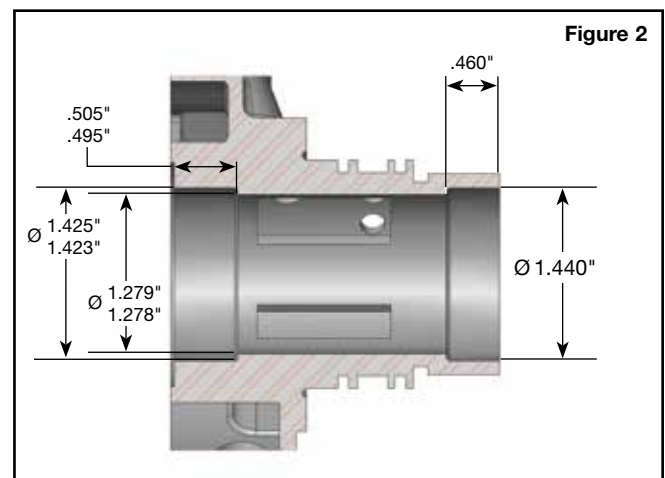

Figure 2