

Chrysler 40/41TE, 41AE, 40/41TES, 42LE/RLE

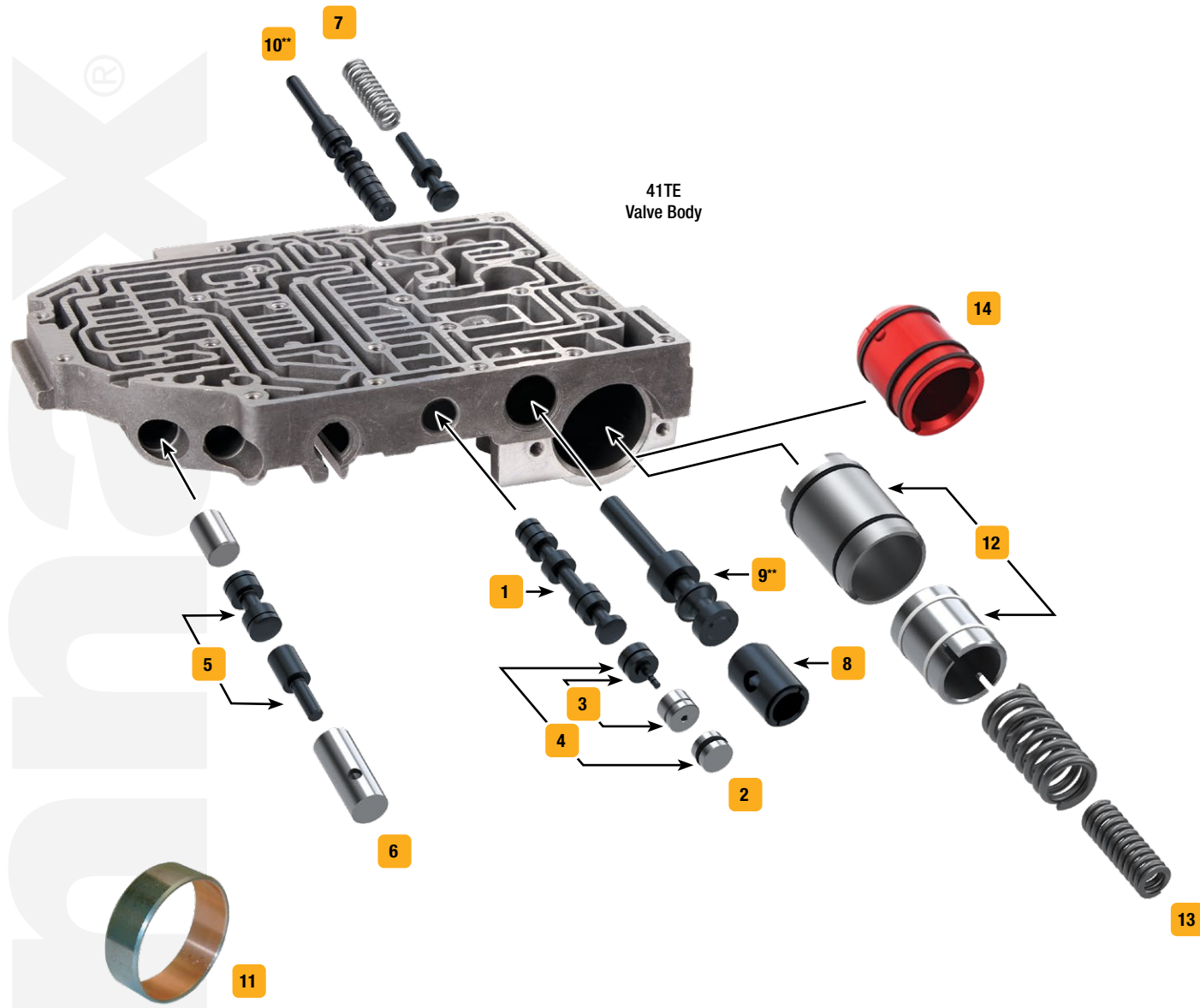

Click on part numbers for product details or visit www.sonnax.com to see all products for the unit(s) shown here.



41TE Valve Body



See kit components at www.sonnax.com.

Symptoms/Part Type	Product Name	Part No.	Details	ZIP Drop-In Zip Valve™ Parts	Tooling
Multiple Symptoms					
Comprehensive kit for big problems you don't want back	The Sure Cure® Kit	SC-41TE	40TE, 40TES, 41AE, 41TE, 41TES, 42LE, non-VLP only		92003-TL
TCC/Lockup Symptoms					
4th Clutch burned, Bind-up, Codes 841, 868, 871, 988, 1775, 1776, Failsafe mode	Oversized Solenoid Switch Valve	1 92835-21	41TE, 42LE, 42RLE only, .420" dia.		F-92835-TL*
Codes 841, 868, 871, 988, 1775, 1776, OD clutch burned, Failsafe mode, Bind-up	Oversized Solenoid Switch Valve & Plug Kit	2 92835-32K	Fits bores containing OE switch valve with .420" dia. large spool only		F-92835-TL32*, 92835-BST †
	Oversized Solenoid Switch Valve & Plug Kit	2 92835-31K	Fits bores containing OE switch valve with .453" dia. large spool only		F-92835-TL31*
	Solenoid Switch Valve Plug Kit	3 92835-02K	ZIP Fits bores containing OE switch valve with .420" dia. large spool only		
	Solenoid Switch Valve Plug Kit	3 92835-39K	ZIP Fits bores containing OE switch valve with .453" dia. large spool with I.D. groove		
Low/Reverse switch code, 2nd Gear starts, Erratic TCC apply, No lockup	Oversized Solenoid Switch Valve Plug Kit	4 92835-18K	41TE, 42LE, 42RLE only, fits bores containing OE switch valve with .420" dia. large spool only		92835-RM, F-92835-TL18*
Codes 841, 868, 871, 988, 1775, 1776, OD clutch burned, Failsafe mode, Bind-up	Oversized Solenoid Switch Valve Plug Kit	4 92835-22K	Fits bores containing OE switch valve with .453" dia. large spool only		92835-RM22
Converter shudder & failure, TCC lockup surge, TCC deflection & lining failure	TCC Control & Plunger Kit	5 92835-03K	ZIP Not for use with #33 separator plates, can be used with all later designs		
Excess TCC slip, TCC shudder, TCC codes, Overheated fluid & TCC lining, Loss of fuel economy	Oversized TCC Control & Plunger Valve Kit	6 92835-33K	Not for use in early 40TE, 41TE, 41AE units with #33 separator plates		F-92835-TL33*
Damaged converter, TCC codes, No TCC release, Excess converter pressure	Oversized TCC Regulator Valve Kit	7 92835-37K	'95-Later		F-92835-TL37*
Pressure Problems					
High line pressure, Harsh shifts, Erratic TCC apply pressure, Poor lube oil control	Pressure Regulator Sleeve	8 92835-07	ZIP 40TE, 41AE, 41TE, 42LE, 42RLE, non-VLP only		
Shift concerns, Low line pressure, Burnt clutches, Poor lube oil control	Oversized Pressure Regulator Valve	9 92835-24	40TE, 41AE, 41TE, 42LE, 42RLE, non-VLP only		F-92835-TL24*
Shift concerns, Low line pressure, High line pressure, Erratic TCC apply	Oversized Pressure Regulator Valve	10 92835-29	40TES, 41AE, 41TES, 42RLE, VLP only		F-92835-TL29*
Pump seal leakage, Pump noise, Loss of prime, Low pump volume, Low cooler flow, TCC codes	Pump Bushing	11 12502-01	Precision, 5/bag		
Shift/Engagement Concerns					
Slide shifts, High CVTs, 1-2 Shudder, Coastdown clunk	Accumulator Piston & Sleeve Kit	12 92834-03K	ZIP Fits in all three accumulator case bores, provides shorter than OE shifts		
	Accumulator Piston & Sleeve Kit	13 92834-05K	ZIP Fits in all three accumulator case bores, restores OE shifts		
High Performance/Heavy Duty Upgrades					
Prevents piston breakage & salvages worn bores	Accumulator Piston Kit	14 44894-01K	ZIP Billet aluminum w/ dual support seals, includes 1 piston		
	Accumulator Piston Kit	14 44894-01MK	ZIP Billet aluminum w/ dual support seals, includes 5 pistons		

* VB-FIX Required

† Recommended Tool

**Note: Valve body shown is non-VLP. Location and design of pressure regulator valve is dependent upon if casting is VLP or non-VLP.