

Ford E4OD, 4R100

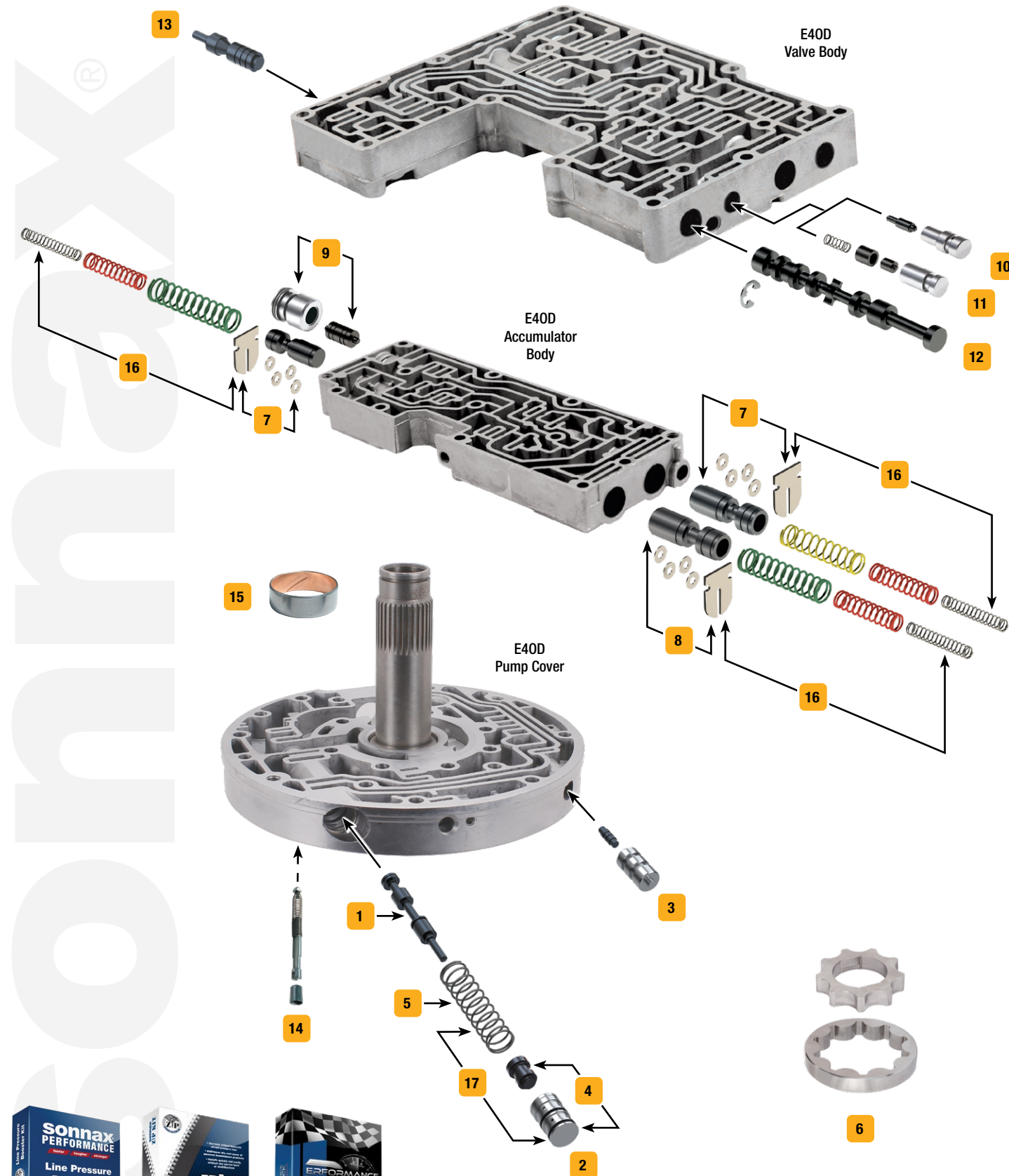

Click on part numbers for product details or visit www.sonnax.com to see all products for the unit(s) shown here.



See kit components at www.sonnax.com.

Symptoms/Benefits	Product Name	Part No.	Details	Tooling
Multiple Symptoms				
The first step in correcting common shift problems	Zip Kit®	E4OD-4R100-ZIP	ZIP	36948-12 †
TCC/Lockup Symptoms				
Code 62, 628, 1744, Engine stall on engagement in Reverse, High line pressure	Line-To-Lube Pressure Regulator Valve	1 36424-04K	ZIP F1, F5, F8 & E9 pump castings	
	Oversized Line-to-Lube Pressure Regulator Valve Kit	2 36424-16K	F1, F5, F8 & E9 pump castings	F-36424-TL16C*
Lockup shudder, TCC cycling	TCC Control Plunger Valve Kit	3 36424-08K	ZIP 4R100 PWM only	
Pressure Problems				
Soft shifts, Delayed Reverse, Low line rise	Boost Valve Kit	4 36424-03K	ZIP Factory style	
	Boost Valve Kit	4 36424-01K	ZIP O-Ring style	
Soft shifts, Poor shift quality, Low base line pressure	Elevated Pressure Main Pressure Regulator Spring	5 36424-10	20/Bag	
Code 62, 628, 1744, Low line pressure, Excess pump noise, Damaged pump gears	Pump Gear Set	6 36438A-03	'95-Later F5 & F8 pump casting	
	Oversized Pump Gear Set	6 36438AX-01K	'95-Later F5 & F8 pump casting	
Shift/Engagement Concerns				
Soft shifts, No 2nd, No 3rd, Premature clutch failure	1-2 & 2-3 Accumulator Control Valve Kit	7 36948-13K	ZIP Fits either of 2 locations	36948-12 †
No 4th, Soft shifts, Premature clutch failure	3-4 Accumulator Control Valve Kit	8 36948-09K	ZIP	36948-12 †
Intermittent harsh shifts, 1-2 Soft, 2-3 Soft, Low line rise, Low EPC pressure	Line Pressure Modulator Plunger Valve Kit	9 36948-03K	ZIP 6- & Small 8-cylinder, .331" dia.	
	Line Pressure Modulator Plunger Valve Kit	9 36948-05K	ZIP Large 8-cylinder, .372" dia.	
	Line Pressure Modulator Plunger Valve Kit	9 96948-01K	ZIP Heavy duty/high performance, .427" dia.	
No engine braking in D1, Burnt Low/Reverse clutch, Low/Reverse clutch distress	Low/Reverse Modulator Plunger Valve Kit	10 36947-06K	ZIP '96-Later, uses lower OE ratio	
No engine braking in D1, Breakaway of Low/Reverse clutch, Burnt Low/Reverse clutch	Heavy Duty Low/Reverse Modulator Sleeve Kit	11 36947-09K	ZIP '96-Later, uses higher OE ratio	
Delayed Reverse, Reverse slip, Low/Reverse clutch failure	Oversized Manual Valve Kit	12 36947-13K		F-36947-TL13*
2nd Gear starts, 3rd Gear starts, TCC cycling, TCC slip	Oversized Solenoid Regulator Valve	13 36947-14	'96-Later, 2-spool valve	F-36947-TL14*‡
Component Damage/Failure				
OD planetary failure	Front Lube/Drainback Valve Kit	14 36425-01K	Melt-proof aluminum	
Leaking front seal, Pump noise, Excess converter hub-to-bushing clearance, Low pump volume	Pump Bushing	15 36002-01	Finish-in-place	
High Performance/Heavy Duty Upgrades				
Significantly firmer shifts at any gear	Line Pressure Modulator Plunger Valve Kit	9 96948-05K	ZIP Extreme heavy duty, .500" dia.	
Heavy duty, high performance calibration kit	Performance Pack	HP-4R100-01	4R100 only	36948-12 †, T36008A †
Aggressive shifts	Performance Rated Accumulator Spring Kit	16 36948-18K	Tri-cumulator springs	36948-12 †
Classic, large-ratio boost valve for crisp, clean shifts without harshness	Line Pressure Booster Kit	17 4R100-LB1	ZIP	

* VB-FIX Required

† Recommended Tool

‡ No longer in production. Check with your distributor for availability.