

GM 4L60 (700-R4)

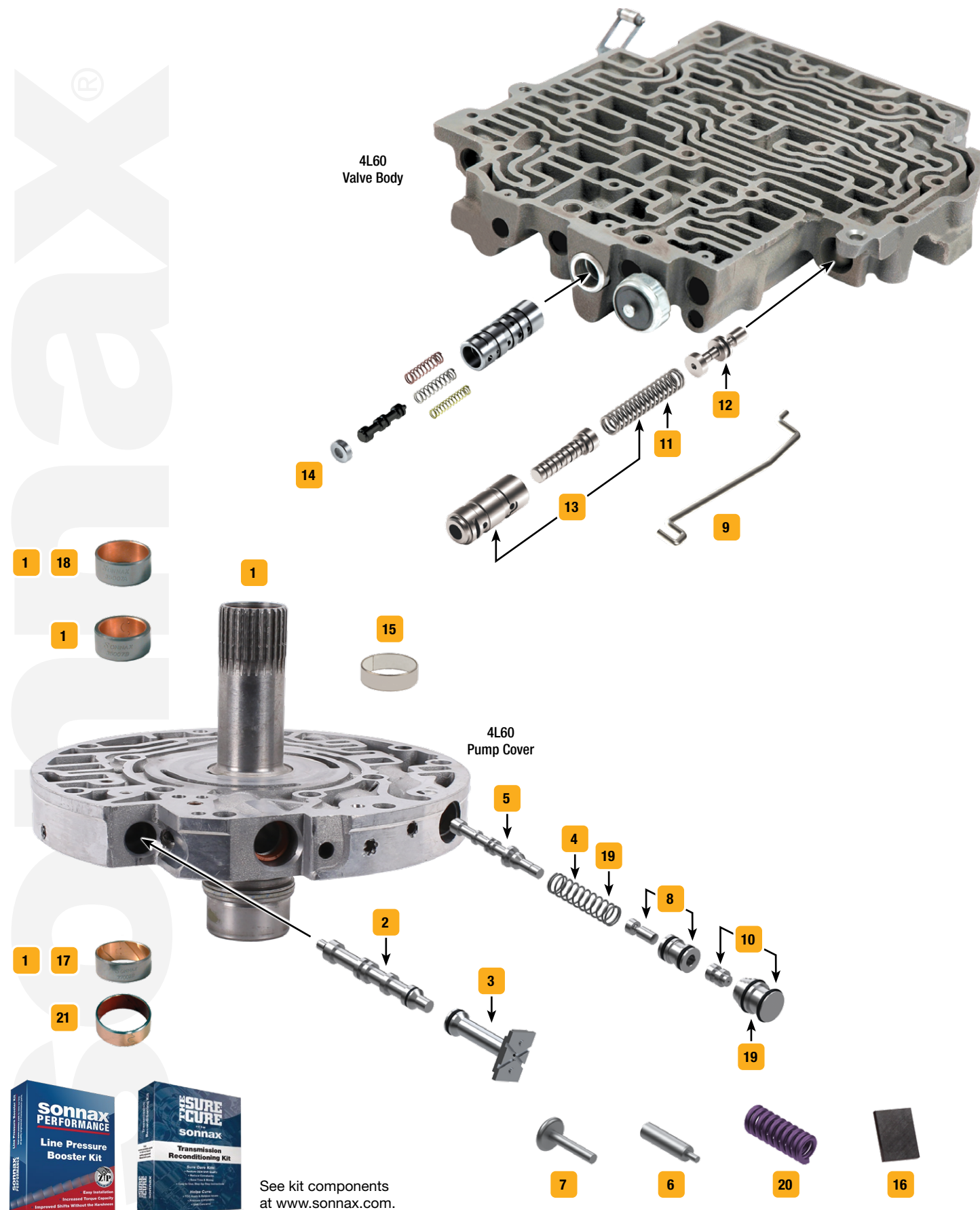

Click on part numbers for product details or visit www.sonnax.com to see all products for the unit(s) shown here.



See kit components at www.sonnax.com.

Symptoms/Part Type	Product Name	Part No.	Details	Tooling
Multiple Symptoms				
Comprehensive kit for big problems you don't want back	The Sure Cure® Kit	SC-4L60		77917-TL
TCC/Lockup Symptoms				
Overheated converter, Worn splines, TCC apply & release concerns	Stator Support Shaft Kit	1 77918S-K	245mm or 298mm Converter, non-reluctor style, universal bolt pattern, includes 3 bushings	
No lockup, Falls out of lockup when hot, Fluid blown out fill tube	TCC Apply Valve Kit	2 77805-K	ZIP	
TCC apply concerns, Overheated converter, Loss of lube oil	TCC Solenoid Snout Kit	3 77942-01K		
Pressure Problems				
Low base line pressure	Elevated Pressure Main Pressure Regulator Spring	4 77917-08		
Erratic line pressure, Low line rise, Clutch slippage, Excess pump noise, 3-4 Clutch failure	Oversized Pressure Regulator Valve	5 77917-06		77917-TL, 77917-TLC
Low line pressure, High line pressure	Pump Slide Pivot Pin	6 65797	5/Bag	
Erratic line pressure	Pump Spring Spacer	7 77917-RV	10/Bag	
Low Reverse boost, Delayed Reverse, Low line pressure, Poor upshift in manual low	Reverse Boost Valve Kit	8 K77898	ZIP Large ratio, O-ring style	
	Reverse Boost Valve Kit	8 K77898A	ZIP Large ratio, factory style	
Low line rise, Soft shifts, 3-4 Clutch failure, 3-4 Band failure	Shortened TV Link	9 77872-01	5/Bag	
Soft slide shifts, 3-4 Clutch burned, Reduced band life	TV Boost Valve Kit	10 77917-03K	ZIP .471" Bore dia., factory style	
	TV Boost Valve Kit	10 77917-02K	ZIP .423" Bore dia., factory style	
	TV Boost Valve Kit	10 77917-471	ZIP .471" Bore dia., O-ring style	
Low throttle pressure, Low line pressure	TV Plunger Spring	11 77968-01K	5/Bag	
Low line rise, Pin bore wear, Soft upshifts, Premature 3-4 clutch failure, Early upshifts	Throttle Valve	12 77968-02	ZIP Aluminum sleeved & non-sleeved units	
Low line rise, 3-4 Clutch & band failure	Oversized Throttle Valve	12 77968	Not compatible with early '82-'90 aluminum sleeved units	77968-RM‡
Low line rise, Early upshifts, Soft upshifts, Premature 3-4 clutch failure	Throttle Valve Plunger Kit	13 77966-94MK	ZIP Prevents forced 4-3 kickdown below three-quarter throttle	
	Throttle Valve Plunger Valve Kit	13 77966-94K	ZIP OE plungers with code 94	
Shift/Engagement Concerns				
1-2 Bang at light throttle, Reduced 2-4 band life	Accumulator Valve Train Kit	14 77777M-K	ZIP '87-Later auxiliary valve body styles only, "M" version valve train in heavy vehicles, .341" dia.	
	Accumulator Valve Train Kit	14 77777L-K	ZIP '87-Later auxiliary valve body styles only, "L" version valve train in light/medium vehicles, .330" dia.	
Component Damage/Failure				
Worn pump bushing	Bushing	15 77005T	Precision, PTFE-lined	
Lost or damaged component	Pump Vane	16 1280	Koyo® (OE), 100/bag	
Bushing wear, Bushing failure	Rear Stator Support Bushing	17 77002B	Precision, wider than OE	
	Stator Support Bushing	18 35007A	'84-Later, 1.004" I.D., precision	
High Performance/Heavy Duty Upgrades				
Classic, large-ratio boost valve for crisp, clean shifts without harshness	Line Pressure Booster Kit	19 700R4-LB1	ZIP	
Maintains high volume slide position at high RPM	Pump Slide Spring	20 77722-01K	Replaces 2 OE springs, 5/bag	
Wider, improved fit & longer lasting	Rear Stator Support Bushing	21 77002BT-01	Precision, PTFE-lined	
Highest TV boost ratio for maximum line rise	TV Boost Valve Kit	10 77917-04K	ZIP .500" Bore dia., factory style	
	TV Boost Valve Kit	10 77917-500	ZIP .500" Bore dia., O-ring style	

‡ No longer in production. Check with your distributor for availability.