

Click on part numbers for product details or visit www.sonnax.com to see all products for the unit(s) shown here.

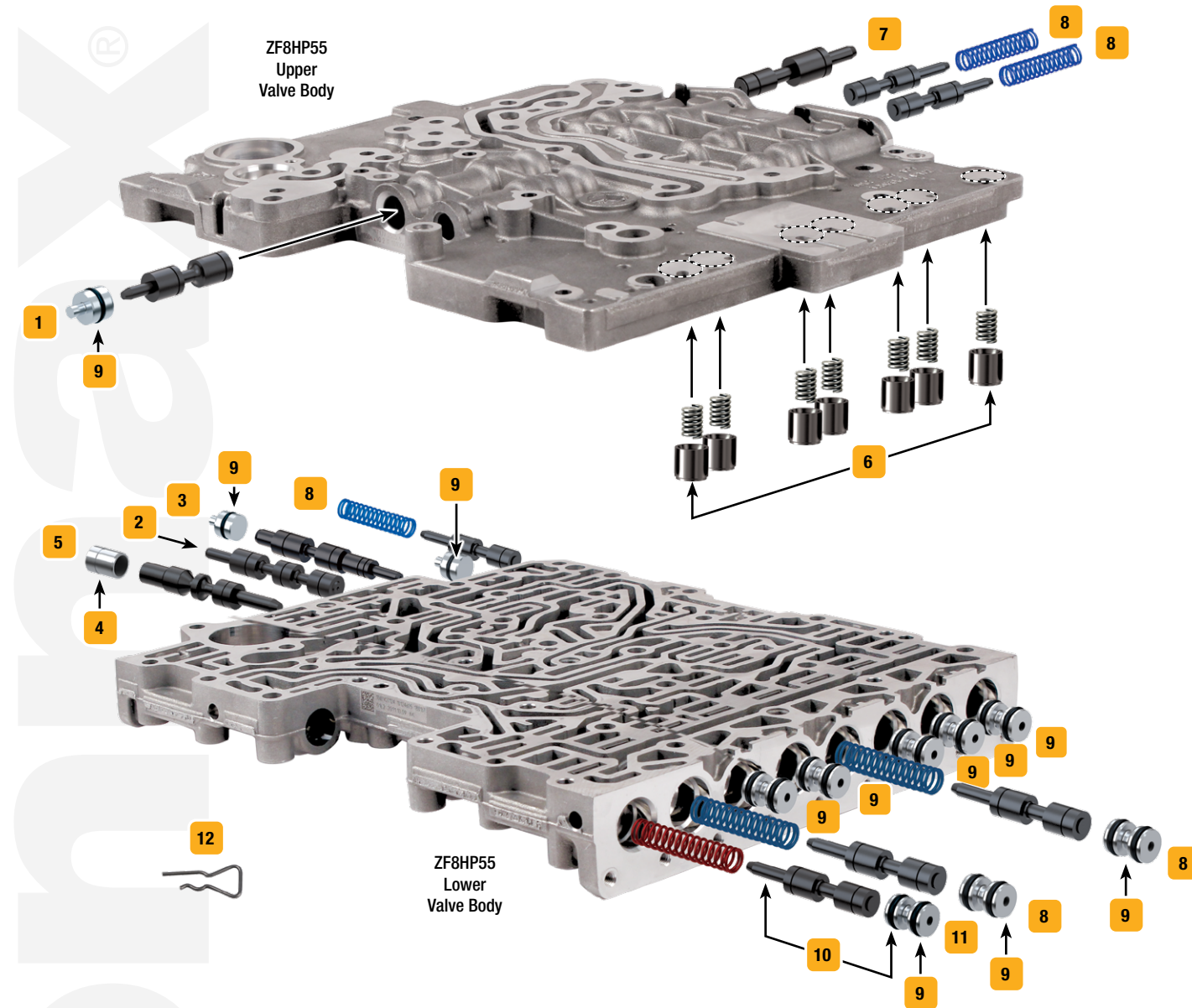

See kit components at www.sonnax.com.



Symptoms/Part Type	Product Name	Part No.	Details	Tooling
Multiple Symptoms				
The first step in correcting common shift problems	Zip Kit®	ZF8-ZIP	ZIP	
TCC/Lockup Symptoms				
Coastdown clunk, Harsh TCC apply, Excess TCC slip, TCC codes & overheating	Oversized TC Pressure Valve Kit	1 35740-18K	ZF valve name: WD-V, Chrysler valve name: TC-V	F-35740-TL5*
No lockup, No TCC release, Engine stall, TCC codes, Excess TCC slip, Premature TCC apply	Oversized TC Switch Valve	2 35740-05	ZF valve name: SV-WD, Chrysler valve name: SV-TC	F-35740-TL5*
Converter shudder & TCC slip, Damaged TCC linings, TCC codes, Overheated converter	Oversized TCC Valve Kit	3 35740-13K	ZF valve name: WK-V, Chrysler valve name: TCC-V	F-35740-TL13*
Pressure Problems				
Harsh shifts, Erratic line pressure, High line pressure, Restricted converter/lube flow	Pressure Regulator Sleeve	4 35740-03	ZIP ZF sleeve name: SYS-DR, Chrysler sleeve name: LP-V	
Harsh shifts, Soft shifts, Erratic line pressure, High line pressure, Burnt clutches	Oversized Pressure Regulator Valve Kit	5 35740-01K	ZF valve name: SYS-DR, Chrysler valve name: LP-V	F-35740-TL*
Shift/Engagement Concerns				
Downshift clunk, Firm shifts, Erratic EDS solenoid control and/or EDS codes	Accumulator Piston Kit	6 95740-15K	ZIP Includes 7 pistons & springs	
Delayed engagement, No Forward, NIC (Neutral Idle Control) concerns, No Reverse	Oversized B2 Clutch NIC Valve	7 35740-22	ZF valve name: KV-B2, Chrysler valve name: CV-B2	F-35740-TL22*
Bump shifts, Burnt clutches, Flare shifts, Gear loss, Gear ratio & solenoid codes	Oversized Clutch Holding Valve Kit	8 35740-20K	Fits 5 separate locations, HV-C & HV-E valve locations use an end plug, HV-A, HV-D & HV-B1 locations do not	F-35740-TL20*
Soft shifts, Flare shifts, Harsh shifts, Burnt clutches, Pressure loss	O-Ringed End Plug Kit	9 35740-30K	ZIP Includes 3 end plugs & 8 internal end plugs	
Harsh shifts, Neutral shifts, Gear loss, Delayed engagement, Wrong gear starts, Flare shifts	Priming Valve & Seal Kit	10 35740-37K	ZIP ZF valve name: DR-RED-V (DR-V), Chrysler valve name: PR-V	
Delayed engagement, Wrong gear starts, Flare shifts, Gear ratio & solenoid codes, Gear loss	Oversized Priming Valve Kit	11 35740-21K	ZF valve name: DR-RED-V (DR-V), Chrysler valve name: PR-V	F-35740-TL20*
Component Damage/Failure				
Lost or damaged component	"Y" Shaped Valve Retainer	12 95740-04K	10/Bag	
Tools				
	Solenoid Test Manifold Kit	35430-VTK		VACTEST-01K

* VB-FIX Required