

Aisin AW TF-60SN

Also fits Mini 6F21WA & VW/Audi 09G, 09K, 09M units

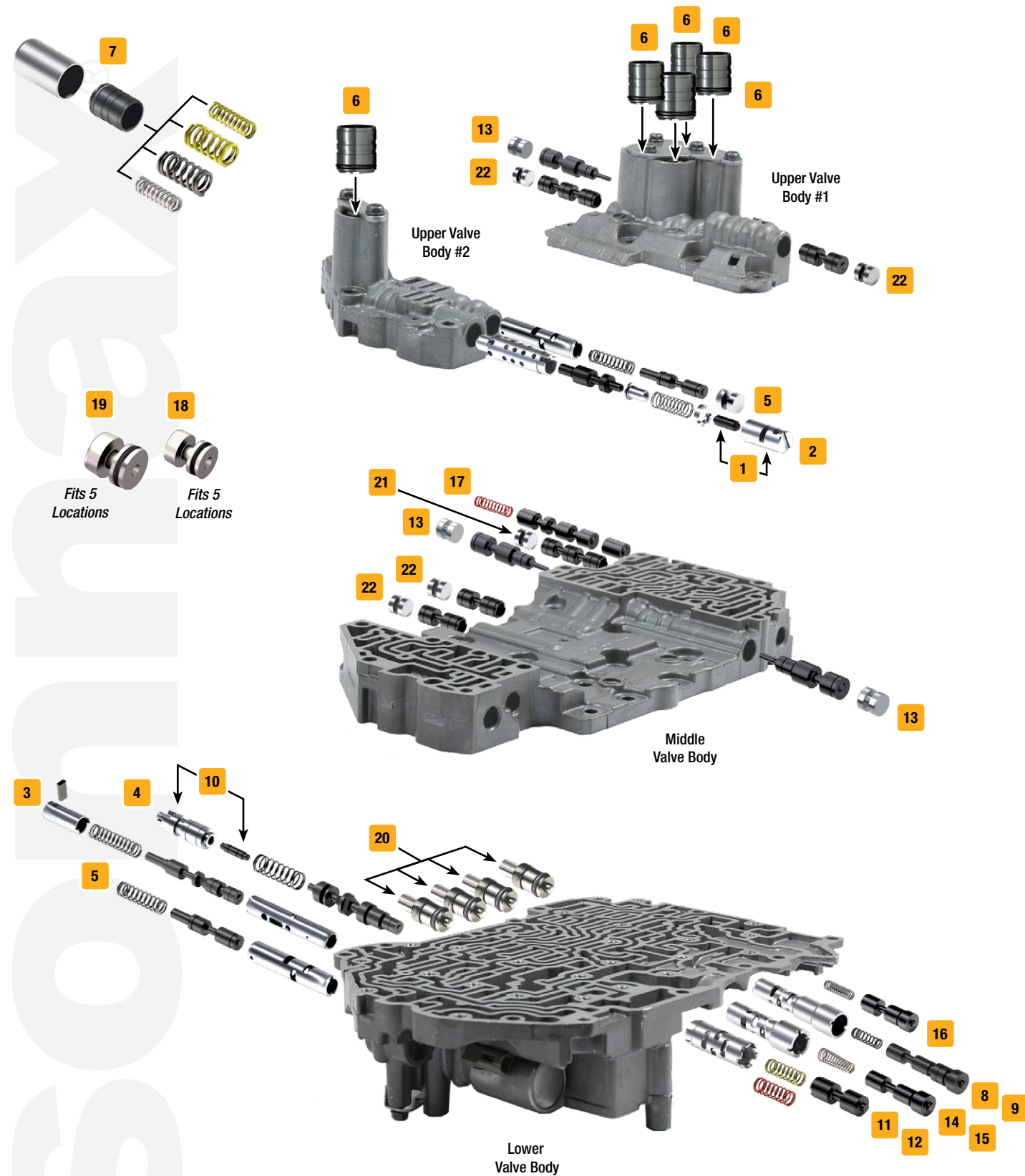

sonnax®

Click on part numbers for product details or visit www.sonnax.com to see all products for the unit(s) shown here.

Symptoms/Part Type	Product Name	Part No.	Details	Tooling
TCC/Lockup Symptoms				
TCC codes, TCC apply & release concerns, RPM surge on light acceleration	Lockup Clutch Control Plunger Valve Kit	1 15741-53K	Also fits Volvo (AM6); Opel (AF40); Peugeot (TF80); Saab (AF40/6); LandRover (TF80); Ford (AF21); Mazda (AW6A-EL)	
TCC codes, TCC apply & release concerns, RPM surge on light acceleration, Harsh downshifts	Lockup Clutch Control Valve Kit	2 15741-29K	Also fits Volvo (AM6); Opel (AF40); Peugeot (TF80); Saab (AF40/6); LandRover (TF80); Ford (AF21); Mazda (AW6A-EL)	F-15741-TL29*
TCC codes, TCC apply & release concerns, TCC slip, TCC surge	Secondary Pressure Regulator Valve Kit	3 15741-11K		15741-TL11
Pressure Problems				
Low line rise in Drive, Low line rise in Reverse, High line pressure in Reverse	Oversized Pressure Regulator Valve & Boost Valve Kit	4 15741-01K		F-15741-TL*
Code 734, 735, 729, Kickdown slip, Kickdown shock, 4th Slip, 5th Slip, 6th Slip	Solenoid Modulator Valve Kit	5 15741-18K	Fits either of 2 locations	F-15741-TL18*, F-15741-TL29PL*
Shift/Engagement Concerns				
Poor shift quality, Forward slip, Delayed engagement, Burnt clutches	Accumulator Piston Kit	6 15741-14K	Fits any of 5 locations	
Severe wear at accumulator bores, Low clutch oil pressure, Low TCC pressure	Accumulator Piston Kit	7 39741-42K	Fits any of 5 locations, includes selective springs	
1-2 Flare, 5-6 Flare, 2nd Slip, 6th Slip, Gear ratio & solenoid codes, B1 Clutches burned	B1 Clutch Control Valve Kit	8 15741-22K	Valve, spring & sleeve	F-15741-TL22*
	Oversized B1 Clutch Control Valve Kit	9 15741-61K	Valve & spring	F-15741-TL61*
Delayed Reverse, Low line rise in Reverse, B2 Clutches burned, K3 Clutch burned	Boost Valve Kit	10 15741-51K		
Coastdown Neutral, Delayed Forward, Gear ratio & solenoid codes, K1 Clutch burned	C1/K1 Clutch Control Valve Kit	11 15741-25K	Valve, spring & sleeve, includes selective springs	F-15741-TL25*
C1 Clutch burned, K1 Clutch burned, Coastdown Neutral, Delayed Forward, Erratic shift timing	Oversized C1/K1 Clutch Control Valve Kit	12 15741-55K	Valve & spring	F-15741-TL55*
Erratic shift timing, Failsafe mode, Harsh shifts, Burnt clutches, Overheated fluid	Oversized Clutch Cutoff Valve Kit	13 15741-63K	Fits 3-4 transition bore, K3 relay bore & 4-5 timing bore	F-15741-TL63*
3-4 Flare, K2 Clutch burned, Gear ratio & solenoid codes, Erratic shift timing, Harsh shifts	K2 Clutch Control Valve Kit	14 15741-05K	Valve, spring & sleeve	F-15741-TL5†
Erratic shift timing, Flare shifts, Harsh shifts, K2 Clutch burned	Oversized K2 Clutch Control Valve Kit	15 15741-57K	Valve & spring	F-15741-TL57*
2-3 Shift concerns, 4-5 Concerns, Delayed Reverse, Gear ratio & solenoid codes	Oversized K3 Clutch Control Valve Kit	16 15741-59K		F-15741-TL59*
Gear ratio & solenoid codes, No 4th, No 5th, No 6th	Oversized Main Relay Valve Kit	17 15741-70K		F-15741-TL70*
Shift concerns associated with circuit pressure loss	O-Ringed End Plug Kit	18 15741-35K	9mm, includes 5 end plugs	
	O-Ringed End Plug Kit	19 15741-36K	11mm, includes 5 end plugs	
Soft shifts, Flare shifts, Long shifts, Shift quality gets worse as temperature increases	Spring Adjuster Kit	20 15741-48K	Fits 4 locations	
Gear ratio & solenoid codes, Various shift concerns, No shift	Oversized Three-Spool Relay/Control/Switch Valve Kit	21 15741-50K	Fits either of 2 locations to replace three-spool OE valve	F-33741B-TL1*
	Oversized Two-Spool Relay/Signal Valve Kit	22 15741-49K	Fits any of 3 locations to replace two-spool OE valve	F-33741B-TL1*

* VB-FIX Required

† No longer in production. Check with your distributor for availability.