

Transmission Report

Volume 1, No. 1

May 2010

Welcome to the Sonnax Transmission Newsletter, Version 2.0!

When Sonnax products are displayed at tech seminars and trade shows, too often we hear, “I didn’t know Sonnax made that part!”

The Sonnax *Transmission Report* is the successor to our *Transmission Technical Bulletin* that featured in-depth technical information for rebuilders. With Internet technology so readily available, we have found the best way to provide tech articles and detailed instructions is now on our industry-leading Web site, www.sonnax.com. But having all that info online does you no good if you don’t regularly visit the Sonnax site.

We hope this publication will help keep you up-to-date on the newest Sonnax parts and point you in the right direction when you head to www.sonnax.com to learn more. As always, we welcome feedback on how Sonnax can help you!

Get It STRAIGHT The Art of Proper Bore Reaming

For years, the Sonnax message has been that if you want to fix that transmission right, you have to fix the valve body. And sometimes the only way to do that is to ream the bore.

Lately, Sonnax competitors have introduced valve body repair products that involve reaming as well. It is gratifying that others are now beginning to understand what Sonnax has been preaching all along! If the bore is worn, and it frequently is, you have to fix that bore to make a quality repair.

We take the art of reaming very seriously at Sonnax. Years of research by the top technicians and engineers in the industry have resulted in many innovative parts and numerous patents for repairs which restore function and durability to the transmissions you rebuild. We make the best valves in the business, but even our valves can be rendered useless if the reaming process doesn’t prepare the bore properly. We know you can’t purchase competing versions and do side-by-side comparisons to see what differences there are between available systems, so Sonnax has done this for you.

...continued on page 2



*Nobody knows
valve bodies like Sonnax.™*

Sonnax remains dedicated to providing root-cause solutions to today’s transmission problems, solutions which safeguard your reputation as a transmission professional.

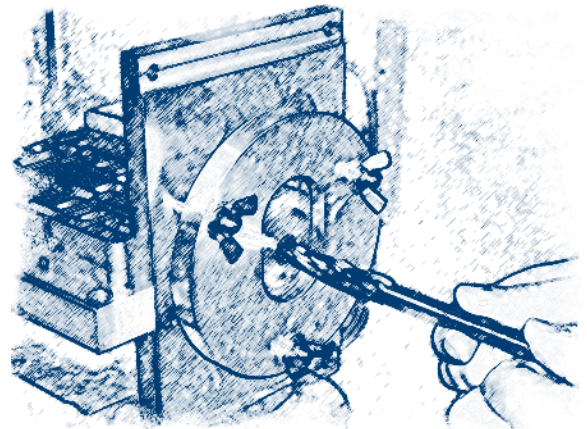

“If the bore is worn, and it frequently is, you have to fix that bore to make a quality repair.”

One common issue that makes a tremendous difference in the quality of bore reaming is reamer alignment. Over the years we have tested many variations of “bolt-on” reamer fixtures. Persistent analysis found that only the patented Sonnax VB-FIX™ reamer alignment system can deliver consistent bore-to-valve clearances.

The VB-FIX process allows you to accurately locate the original bore centerline and then securely hold the reamer, ensuring that the reamed bore will remain on that centerline (see **Fig. 3** on page 3). Concentricity through the entire length of the bore is critical to correct valve fit and function.

**NOTE TO REBUILDERS:
Not all valve body reaming kits are created equal!**

Here we have looked at bores for the Mercedes 722.6 and the Chrysler TV. Vacuum testing and precision measurements were performed with a state-of-the-art Coordinate Measuring Machine (CMM) to bring to light details that cannot be seen with the naked eye. The precision of the CMM allows us to measure and then generate detailed traces.

As you can see in **Fig. 1**, the bore trace of a Chrysler TV bore reamed with the Sonnax VB-FIX system shows perfectly straight, properly aligned bore lands. By comparison, with a competitor’s system, the deeper you ream, the further out of alignment you become.

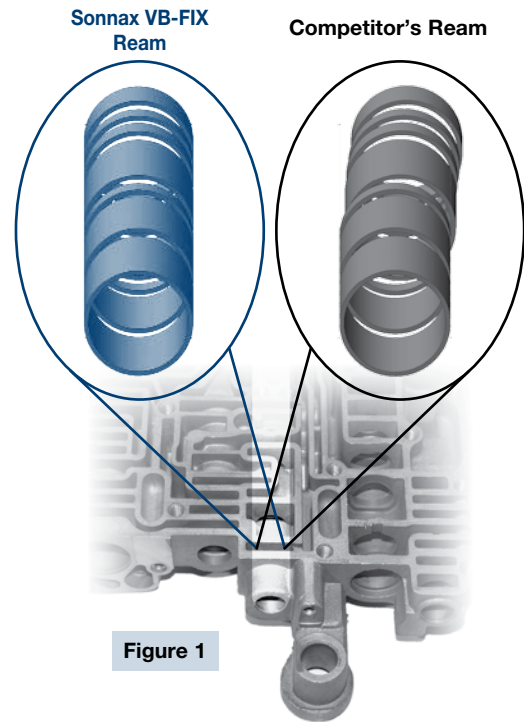
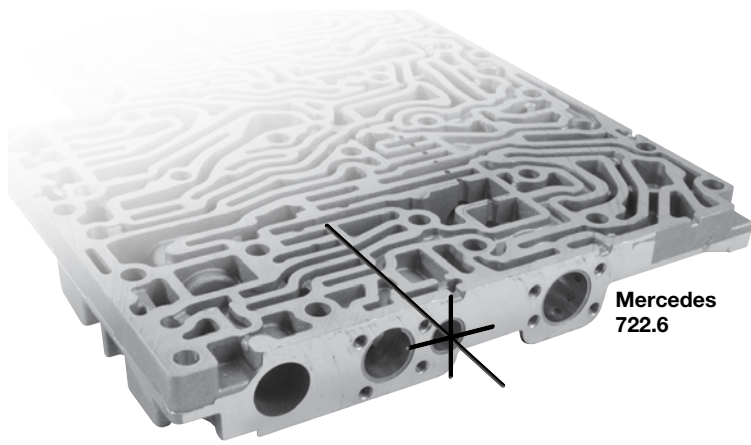

Figure 1



Mercedes 722.6

The Numbers Don't Lie

Analysis has shown that gasket and end cover surfaces are not always aligned with bores. Over a 3" bore, misalignment of one tenth (.1) of one degree will result in five thousandths (.005) of an inch misalignment at the inner lands of the bore.

The patented Sonnax VB-FIX precisely aligns the reamer with the center of the bore, guaranteeing consistent bore-to-valve clearances.

Vacuum Testing Proves the Differences

In the case of a Mercedes 722.6 lube regulating valve (see **Fig. 2**), the competitor’s system results in leakage that compares to used valve bodies. The Sonnax VB-FIX repair has more precise clearances and, while the valve still drops in perfectly without binding, the leakage is greatly reduced compared to used and competitors’ repairs.

Of course, reaming on center is not the only issue. Accurate and efficient reamer geometry is required. Leaving a precisely sized bore that allows free valve movement without excess clearance is equally important. We should know, we have been doing it for years.

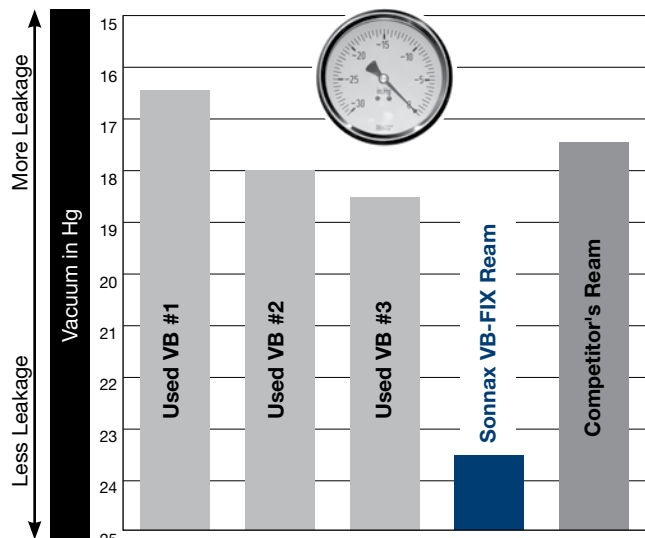

Figure 2 Vacuum tests demonstrate clearance between valve and bore. Lower vacuum reading value indicates greater clearance and greater leakage.

What's the VB-FIX?

Produces consistent, reliable results and minimizes the potential for reaming errors.

In certain applications there is no way to pilot a reamer to repair a worn valve body, forcing rebuilders to purchase new ones.

The patented Sonnax VB-FIX™ is a self-aligning fixture that provides an external rigid pilot bore for the reamer and guide pin, allowing the fixture to be used on multiple valve bodies and valve bores.

The VB-FIX base is large enough to provide ample support for the valve body. For vehicles with bores located inside the large pump bodies, an oversize pump base plate - the VB-06 - can be easily mounted to the VB-FIX.

Special tool kits designed to service a specific bore are used with the VB-FIX. Sonnax part numbers for these kits begin with an "F-" to distinguish them from stand-alone Sonnax tools.

The VB-FIX is designed to be quick & easy to use.

The diagram below demonstrates the VB-FIX and a Sonnax "F-" tool reamer in use. Detailed reaming instructions for Sonnax tool kits requiring the VB-FIX are available online at www.sonnax.com.

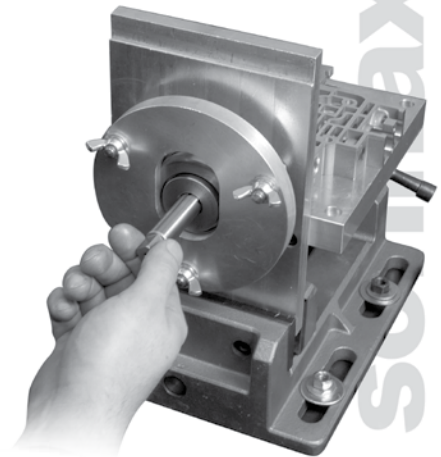

Part No. VB-FIX Patent No. 7,220,085

- Base Plate
- Clamp Mounting Plate
- Clamp Plate
- Outer Races (2)
- Inner Race
- Studs, Washers & Wing Nuts (3 each)
- Socket Cap Screws (4)

Figure 3

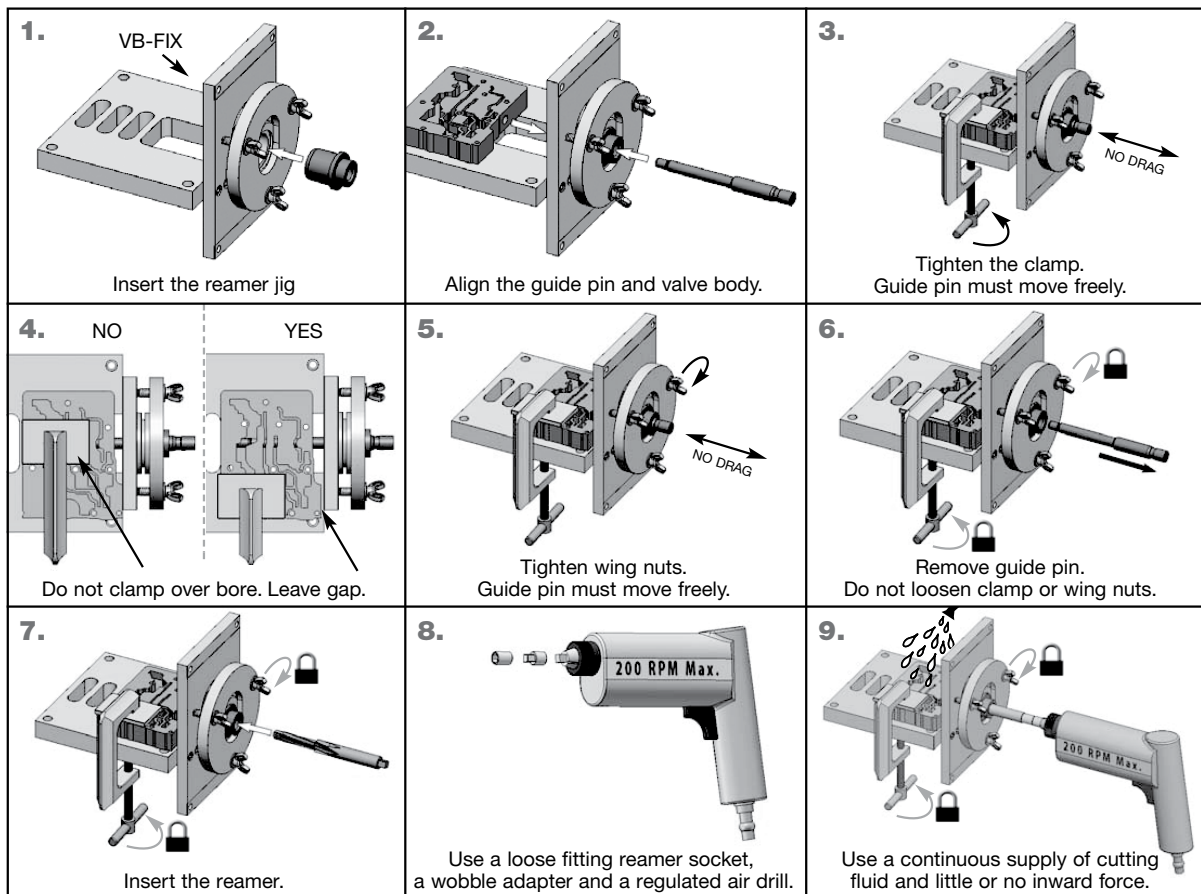

1 Part #68942-05K

Overlap Control Valve Sleeve Kit

Helps cure:

- Harsh, bumpy or flare shifts
- Slipping gears

Note: Kit includes (1A) 68942-04, (1B) 68942-03, (1c) 68942-02, which are also available separately.

2 Part #68942-31K

Coming soon!



3-4 Overlap Valve Kit

Helps cure:

- Harsh, bumpy or flare 3-4 shifts
- Slipping gears

Note: Requires tool kit F-68942-TL31 & the VB-FIX reaming fixture.

3 Part #68942-16

Oversized Manual Valve

Helps cure:

- Reduced line pressure
- Delayed drive/reverse engagement
- Loss of valve body core

Note: Requires tool kit F-68942-TL16 & the VB-FIX reaming fixture.



4 Part #68942-23K

TCC Damper Valve & Sleeve Kit

Helps cure harsh lockup.



5 Part #68942-10K

TC Lockup Clutch Regulator Valve Kit

Helps cure:

- Converter apply/release complaints
- Converter codes & lube failures
- Bore wear

Note: Requires tool kit F-68942-TL10 & the VB-FIX reaming fixture.

12 Sure-Fix Valve Kits

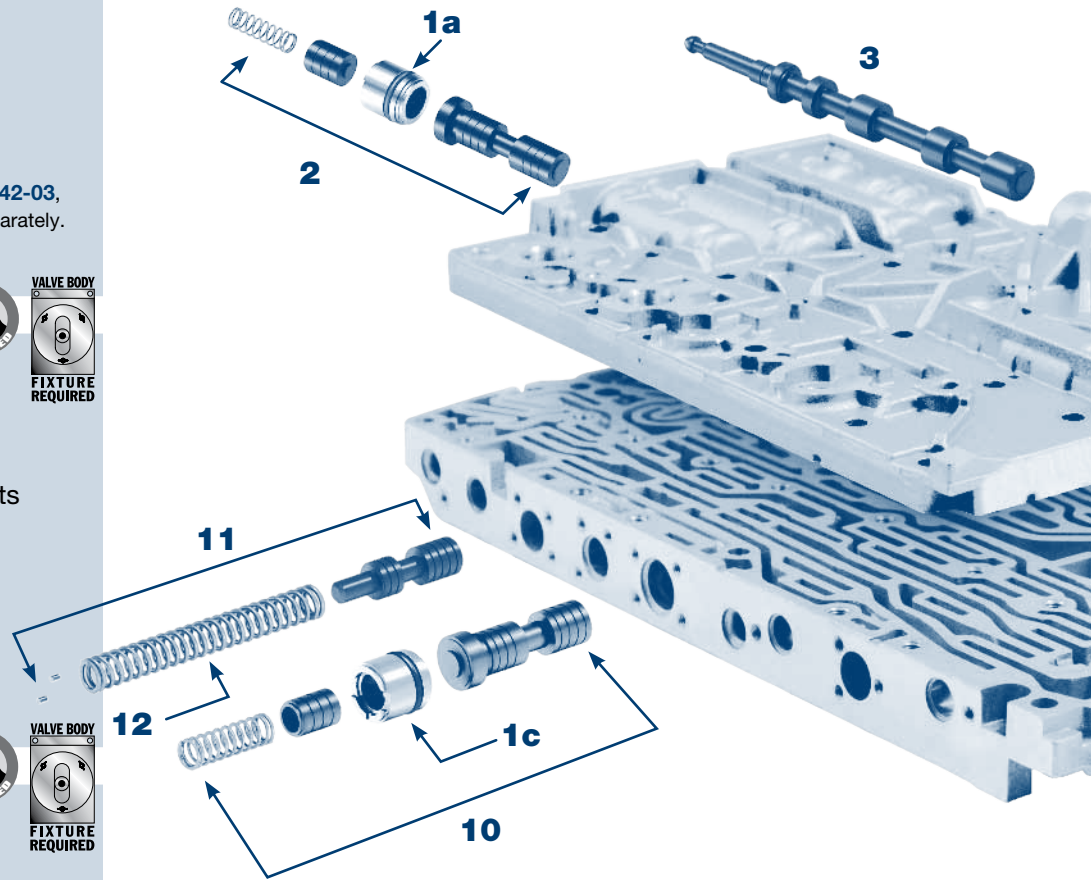

6 Part #68942-27K

Coming soon!



2-3 Overlap Valve Kit

Helps cure:

- Harsh, bumpy or flare 2-3 shifts
- Slipping gears

Note: Requires tool kit F-68942-TL27 & the VB-FIX reaming fixture.

7 Part #68942-14K

Lubricating Pressure Control Valve

Helps cure:

- Delayed engagements
- Poor performance/higher stall speeds
- Converter overheat

Note: Requires tool kit F-68942-TL14 & the VB-FIX reaming fixture.



for Mercedes 722.6

View more of our helpful valve body layouts online at www.sonnax.com
A Transmission Digest Top 10 Tool of 2009!

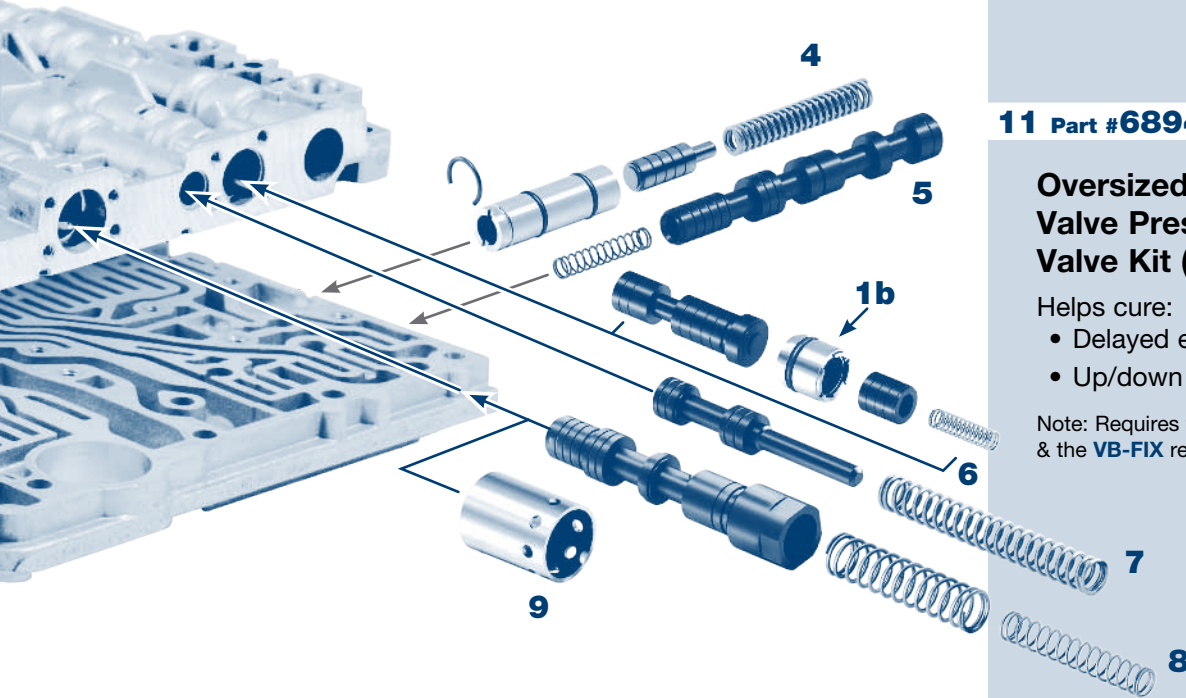

10 Part #68942-19K



1-2/4-5 Overlap Valve Kit

Helps cure:

- Harsh, bumpy or flare 1-2/4-5 shifts
- Slipping gears

Note: Requires tool kit **F-68942-TL19** & the **VB-FIX** reaming fixture.

11 Part #68942-17K

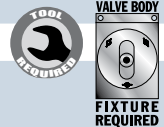

Oversized Regulating Valve Pressure Control Valve Kit (Early & Late)

Helps cure:

- Delayed engagement
- Up/down shift flare

Note: Requires tool kit **F-68942-TL14** & the **VB-FIX** reaming fixture.

12 Part #68942-01

Regulating Valve Pressure Control Valve Spring ('99 & Earlier Units)

Helps cure:

- Delayed engagements
- Flared 2-3, 3-4 or 4-5 shifts

8 Part #68942-07K

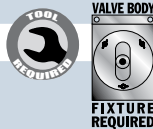

Pressure Regulator Valve Kit

Helps cure:

- Loss of 2-3 shift
- 4-3 neutral on downshift

Note: Requires tool kit **F-68942-TL7** & the **VB-FIX** reaming fixture.

9 Part #68942-06

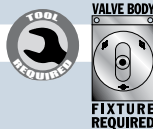

Outer Pressure Regulator Sleeve

Helps cure:

- Loss of 2-3 shift
- 4-3 neutral on downshift

Note: Requires tool kit **F-68942-TL6** & the **VB-FIX** reaming fixture.

MORE Sonnax Valve Body Solutions

You asked for them and we developed them!

- **Jatco RE5R05A**
- **Aisin Warner TF-60SN, TF-80SC, TF-81SC**
- **Aisin Warner 55-50SN**
- **Toyota U151E/F, U250E**
- **Toyota U140E/F, U240E, U241E**

View Sonnax valve body layouts & parts at www.sonnax.com.

***No one works a transmission as hard as your customers.
No one helps protect them like SONNAX.***

Input Shaft/Hub Assembly

Chrysler 47RH/RE, 48RE

A Sonnax best-seller!

This heavy-duty, one-piece input shaft/forward clutch hub eliminates the weak connection between the input shaft and forward clutch hub by combining the two into a one-piece design.

The assembly is made from a high-strength, one-piece 300M steel forging that is heat treated and shot peened to exacting specifications.

This popular assembly was voted a Top 10 Product of 2008 by the readers of *Transmission Digest*.



Part No. 22121B-01

- One-piece design
- Use with OEM seals
- 23-tooth input spline, 62-tooth clutch spline

Heavy Duty Kickdown Band Strut

Chrysler 727, 46-47RH/RE, 48RE

Prevents Strut Transmission Damage

Chrysler transmissions used in high performance applications often bend or break the kickdown band strut. To eliminate this problem, Sonnax has designed a high performance band strut that features high strength, heat-treated steel with a thicker center section.

The 22825-01 is easy to install:

1. Remove the pan and valve body to expose the bottom of the transmission.
2. Loosen the adjusting screw to remove all tension from the band.
3. Remove the original strut.
4. Insert the **22825-01** strut with the flat surface facing away from the band.
5. Tighten the adjusting screw and set to manufacturer's standards.



Part No. 22825-01

- Made of high-strength steel
- Withstands the increased band apply forces in performance applications



Become a Sonnax Insider!

E-mail is the fastest way to get all the latest news from Sonnax.

- Be the first to know about new Sonnax products
- Stay on top of industry trends
- Discover helpful technical resources
- Learn about upcoming seminars and industry events

Sign up today at www.sonnax.com

New! Accumulator Piston Kit

Chrysler 727, 904, 42-46-47RH/RE, 48RE

Dual-Sealing for Optimum Performance

OE plastic accumulators are prone to breaking and have poor sealing qualities. Metal rings currently offered with aftermarket accumulators have issues with sealing as well.

The new Sonnax 22841-04K Accumulator Piston Kit features a dual seal Teflon®/D-ring accumulator piston. The Teflon® seal prevents piston-to-bore contact, while the D-ring seal vastly improve sealing compared to steel rings currently offered by the aftermarket.

A 22841-04SK replacement seal kit also is available.

Kit 22841-04K includes:

- Accumulator Piston
- Teflon® Seals (2)
- D-Ring Seals (2)

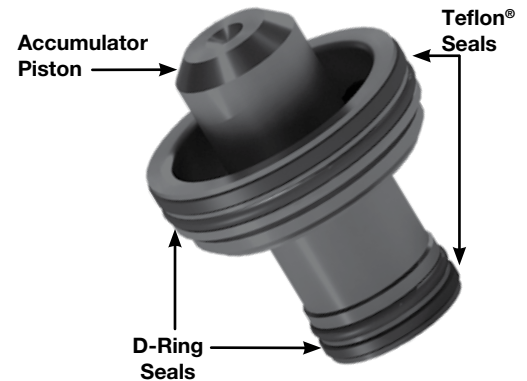

Part No. 22841-04K

- Made from anodized billet aluminum
- Dual seal “Teflon®/D-ring” design provides superior sealing capability

New! 2nd Gear “Super Hold” Servo Assembly

Chrysler A727, 46-47RH/RE, 48RE

The largest, most leak-free servo available on the market!

For higher horsepower applications, this servo reduces the need for aggressive lever ratios, excessively high line pressure and other more radical modifications to achieve firmer shifts. It features 16% more apply area than the OEM servo.

The improved sealing of the small and large diameters of both the piston and cover eliminates cross leaks, resulting in 15% less leakage than other designs. Rubber and Teflon® seals enhance positive sealing and prevent piston contact and bore scuffing.

The smaller diameter apply pin along with the greater 2nd apply area maintain a favorable apply-to-release area ratio and minimize shift overlap on the 2-3 shift. The result: more holding force in 2nd, firmer 1-2 and 2-3 shifts that become firmer under load.

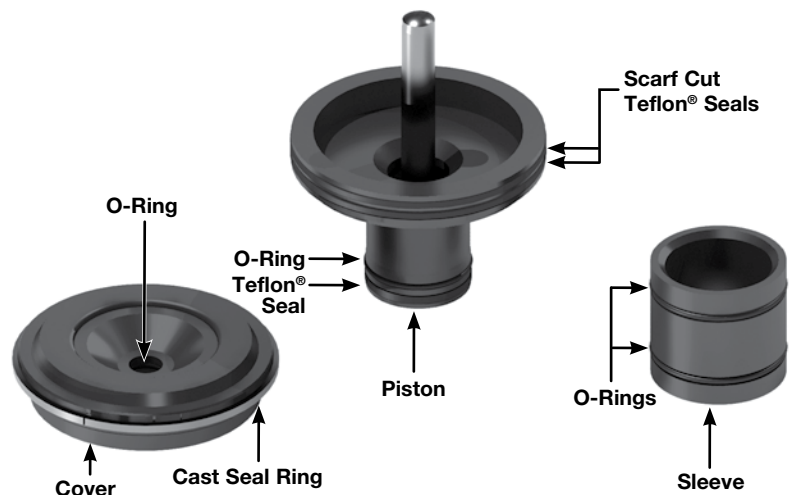

Part No. 22301B - 01K

- 16% more apply area for more band holding power in 2nd gear
- One easy-to-install part improves 1-2 and 2-3 shifts
- Improved seal design conserves pump volume
- Red anodized