

## Transmission Report

Volume 6, No. 1

February 2015

### Sometimes the Best Tools are FREE!

- Technical Articles
- Roadshow Seminars & Tech Visits
- Vacuum Testing Tutorials & Guides
- Valve Body Exploded Views
- Expert Technical Support
- Robust Online Product Information & Search Options

Sonnax believes strongly in sharing knowledge that will benefit the transmission aftermarket industry. That's why we offer rebuilders a wide range of helpful, free "tools" of the trade to help shops build the best transmissions.

This year Sonnax is rolling out exciting new "tools" such as webinars, training videos and personalized instruction. Learn about these and other resources in this newsletter, or visit [www.sonnax.com](http://www.sonnax.com) to check out all the latest offerings.



#### GM Gen. 1 6T40/45/50 Concerns & Repair Techniques

- 6T40 (GF6) Hydraulic Systems
- Pressure Switch Functions
- Gen. 1/2/3 Differences & ID Tips
- Valve Body & Pump Diagnostics

#### Four sessions!

Join Sonnax Tech Specialist Steve Garrett at noon on

- March 17 EDT, MDT
- March 18 CDT, PDT



#### Learn from the Best

Live webinar sessions with Sonnax tech specialists deliver transmission expertise into your hands.

- Choose from convenient lunch-hour sessions in your time zone.
- Join via computer or phone/tablet.
- Ask questions and request additional tech support.
- Download detailed handouts and access full webinar after each event.

Sign up today for  
this FREE Webinar  
at [www.sonnax.com](http://www.sonnax.com)





Watch at [www.sonnax.com](http://www.sonnax.com) or 



Watch  
Now



# Product Demos Training Videos Tradeshaw Highlights

## Intro to Vacuum Testing

with Sonnax Tech Specialist Jim Dial

### Part 1 What is Vacuum Testing?

- What are the benefits of valve body vacuum testing?
- How does valve body wear lead to transmission problems?
- What does vacuum testing tell you about a valve body?
- How to get started vacuum testing.

### Part 2 Test Stand Setup & Calibration

- The basic equipment necessary for vacuum testing.
- How to set up Sonnax vacuum test stand kit VACTEST-01K.
- How to calibrate the test stand before beginning to test.

### Part 3 How to Vacuum Test

- Proper usage of Sonnax vacuum test stand kit components.
- Matching common transmission symptoms to problem areas in the valve body.
- Reading and using Sonnax vacuum testing guides.
- Establishing pass/fail standards aligned with customer's needs and shop warranty requirements.

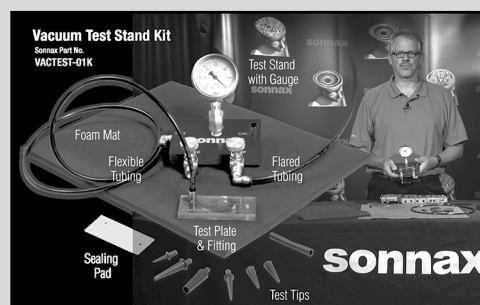
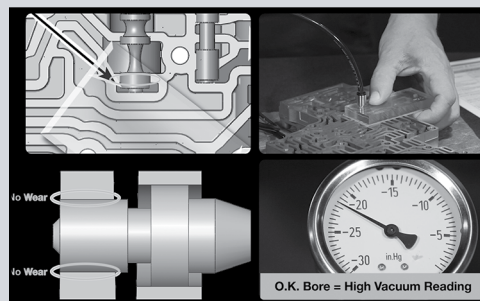

## More Sonnax Videos

### Pressure Switch Installation

Seeing is believing! Watch how easy Sonnax makes it to complete fast, safe, effective pressure switch repairs for GM 6L-series and Gen. 1 6T70, 6T75 units. [Details on next page!](#)

### Zip Kits® 101

Learn the causes of common shift problems and why Sonnax Zip Kits are the BEST choice for restoring and extending shift quality.

### Live from the Show!

The Sonnax team showcases the newest products and cutting-edge innovations from three fall automotive industry events:

**Powertrain Expo**  
**SEMA • PRI Show**

# FIVE New Zip Kits



## No Reaming Required!

**Stops Critical Hydraulic Leaks**

**Includes In-Depth Tech Booklet**

### THE FIRST STEP

in Correcting Common Shift Problems

Not shown:

- Checkballs (2)
- Case Connector
- O-Ring

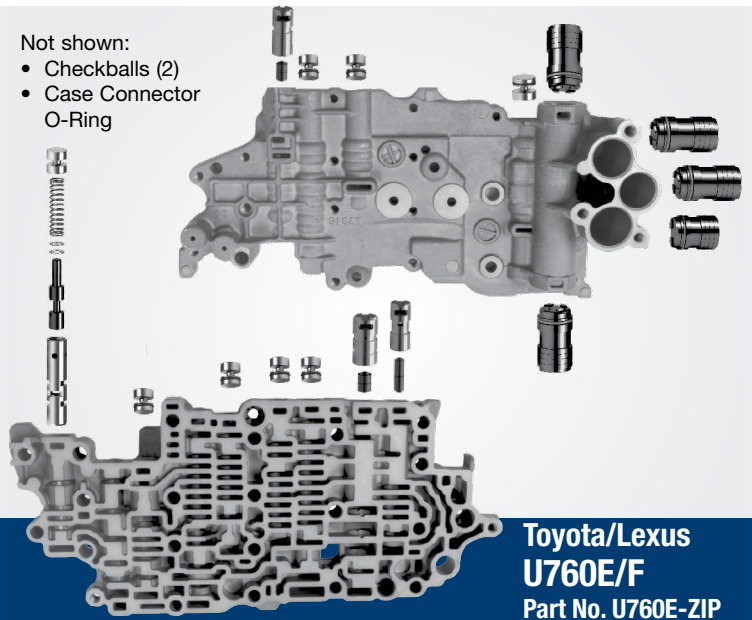

**Toyota/Lexus U760E/F**  
Part No. U760E-ZIP

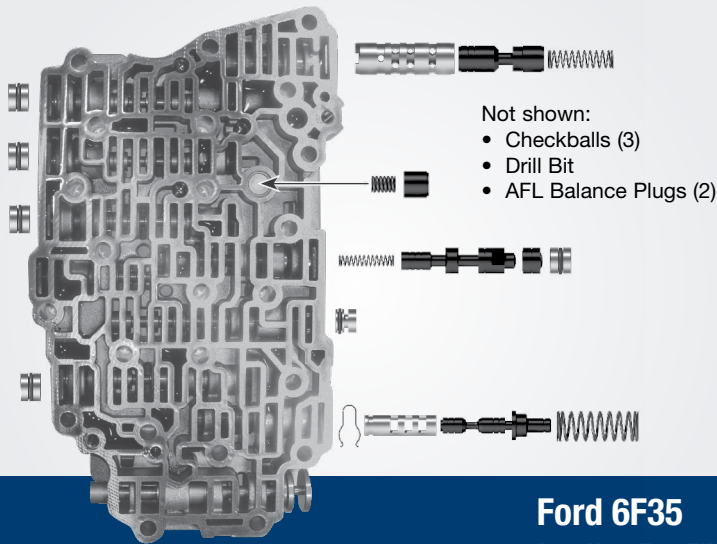

**Ford 6F35**  
Part No. 6F35-ZIP

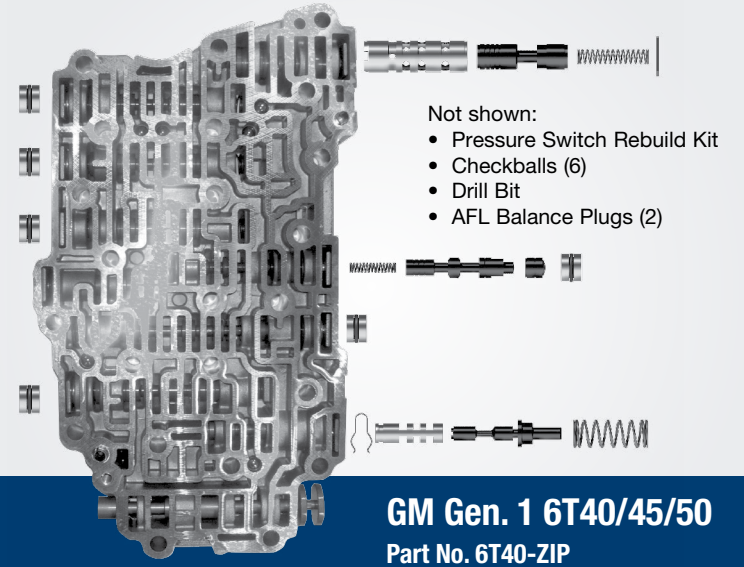

**GM Gen. 1 6T40/45/50**  
Part No. 6T40-ZIP

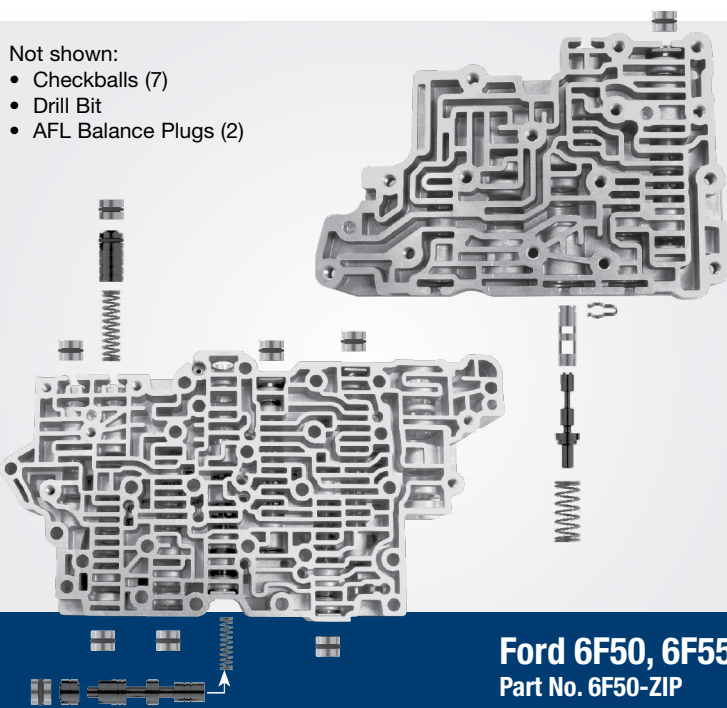

**Ford 6F50, 6F55**  
Part No. 6F50-ZIP

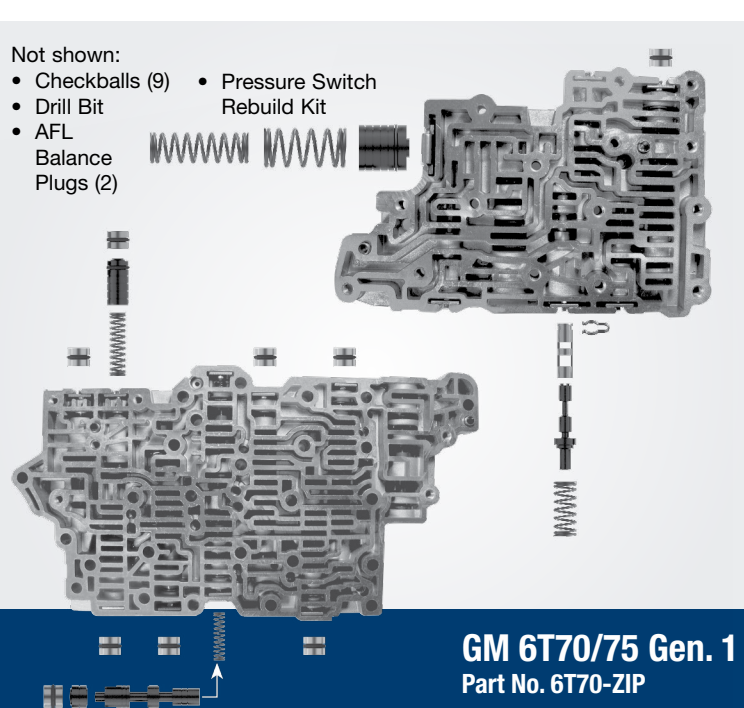

**GM 6T70/75 Gen. 1**  
Part No. 6T70-ZIP

What can be better than saving hundreds by rebuilding the TEHCM, instead of buying an expensive replacement?

## Successful pressure switch repairs the **FIRST** time, **EVERY** time!

See how easy it is! Watch the **Installation Demo Video** at [www.sonnax.com](http://www.sonnax.com)

Watch Now



### A comprehensive & systematic approach to pressure switch rebuilds - that's Sonnax!

GM 6-speed transmissions often set various trouble codes related to failures of fluid pressure switches in the TEHCM. These codes may be accompanied by TCC apply problems or shift irregularities such as slipping, flares, harsh application and bind-ups.

As time goes by, laminated portions of pressure switches can breach, preventing normal switch operation. Failsafe mode can be triggered if more than one switch breaks down.

As an easy, affordable alternative to replacing the costly TEHCM, Sonnax developed these unique pressure switch rebuild kits to restore normal switch operation.

**Note:** Before installing Sonnax kits, test switches to verify proper electrical operation. Detailed testing instructions come with every kit and can be found at [www.sonnax.com](http://www.sonnax.com).

No practicing. No coaxing.  
Just the right tools & parts for effective, affordable pressure switch rebuilds.

## Pressure Switch Rebuild Kits

**6L45, 6L50, 6L80 & 6L90 • Gen. 1 6T70 & 6T75**

### Rebuild Master Pack

124740-28K *Patent Pending*

10 sets of TEHCM rebuild seals and laminate discs, plus the installation tool kit.

### Installation Tool Kit

124740-TL30 *Patent Pending*

Disc install tool and seal install tool, plus one set of seals and discs.

### Rebuild Kit

124740-30K

One set of seals and discs. Tool kit required.

**Gen. 1 6T40, 6T45 & 6T50**

### Rebuild Kit

144510-09K *Patent Pending*

One set of TEHCM rebuild seals, laminate discs and spacers.  
*No Special Tools Required*



## Online Build Charts

For 4L60-E Heavy Duty Pickup  
& Performance Upgrades

# Plow Repairs & Upgrades

These top Sonnax repairs and upgrades are ideal for getting valuable plow trucks vehicles on the road and going strong before the next storm hits.

★ **Best of the Best**  
for this Application

Description	Part No.
<b>Ford 5R110W</b>	
★ <b>Low/Reverse Retaining Ring</b>	36885
Pressure Switch O-Ringed End Plug Kit	36940-17K
<b>Ford E4OD/4R100</b>	
Line Pressure Booster Kit	4R100-LB1
★ <b>Performance Pack</b>	SC-4R100HD
Line-To-Lube PR Valve	36424-04K
Heavy Duty Low/Reverse Modulator Sleeve Kit	36947-09K
Cooler Bypass Valve Kit	36605-02K
Front Lube/Drainback Valve Kit	36425-01K
Intermediate & Direct Clutch Feed Seal Kit	36424-24K
<b>Ford AODE, 4R70W</b>	
Line Pressure Booster Kit	4R70W-LB1
Oversized PR & Boost Valve Kit, '91-'95	76948-16K
Oversized PR & Boost Valve Kit, '96-Later	76948-17K
★ <b>Valve Body Retainer Plate Kit</b>	76507F-01K
Overdrive Servo Pin Kit	76833E
<b>Chrysler 618/48RE</b>	
Lube Regulated PR Valve	22771A-10K
Oversized Throttle Valve Kit	22771-04K
★ <b>Input Shaft</b>	22121B-01
2nd Gear Super Hold Servo Kit	22301B-01K
Accumulator Piston Kit	22841-04K
Reverse Servo Piston Plug Kit	22912-01K
Rear Servo Piston	22912
6-Tab Thrust Washer	22700GT-01

Description	Part No.
<b>Chrysler 68RFE/545RFE</b>	
Center Pump Gear	72530B-02
★ <b>Oversized Solenoid Switch Valve Plug Kit</b>	92835-18K
TC Limit Valve & Sleeve Kit	44912-03K
Accumulator Cover Plate	44892-01K
<b>GM 400</b>	
Line Pressure Booster Kit	400-LB1
Forward Clutch Hub	34322-01
<b>GM 4L80-E</b>	
Line Pressure Booster Kit	4L80E-LB1
Lube Regulated PR Valve	34200-14K
★ <b>Reverse Servo Spacer Kit</b>	34528-01K
Bushing	34006-SP
Boost Valve Kit	34200-10K
Actuator Feed Limit Valve Kit	34200-16K
Manual Shift Shaft Kit	38511-01K
<b>GM 4L60-E</b>	
Line Pressure Booster Kit, Early-Style	4L60E-LB1
Line Pressure Booster Kit, Late-Style	4L60E-LB2
Performance Pack	HP-4L60E-01
★ <b>Heavy Duty 2-3 Shift Valve</b>	77754-41
Bushing	77002BT-01
Input Drum Reinforcement Sleeve & Seal Kit	77733-02K
SmartShell® Heavy Duty Reaction Shell Kit	77749-02K
Forward & Reverse Abuse Bore Plug	77754-21
★ <b>Heavy Duty Output Shaft</b>	74678S-HD
<b>GM 6L80/ 6L90</b>	
Line Pressure Booster Kit	6L80-LB1
Zip Kit®	6L45-6L90-ZIP
<b>New Process 230 &amp; 240 Series</b>	
Transfer Case Split Ring Retainer	100420-02K
Transfer Case Pump Plate Kit	100246-02K



## Robert

**Tech Support Representative**

**Robert's Years on the Team: 4**

Robert Moreau's main focus is providing Sonnax transmission technical assistance on various online forums, from the largest - like TRNW - to the smallest. Many know him by his online handle, "Tranibob." Based in California, he's a regular presenter at West Coast Sonnax Roadshow seminars.

Prior to working for Sonnax, Robert was a transmission rebuilder for more than 20 years, owned a transmission shop for 11 years and worked the hotline for AAMCO for a year.

According to Robert, Sonnax has given him a great opportunity to do what he loves to do by helping the guys in the trenches and ensuring the industry has a great future.

One of the greatest things about online forums for transmission specialists is how people from all over share their ideas.

For example, technicians were talking about all kinds of creative ways to use transparent, rubbery material to seal a vacuum test plate against a valve body (instead of using assembly lube).

The demand was there for a solution, and Sonnax was right there too, trying to figure out how to make this concept work. That led to the creation of Sonnax's new silicone pads, which are custom-designed to make sealing the Sonnax vacuum test plate on the valve body child's play.

**Vacuum Test Plate Sealing Pad**  
Part No. VACTEST-06



**Here are a few similar great ideas I've seen in my online travels related to vacuum testing:**

- When vacuum testing, use a piece of ear plug to block passages in the valve body worm tracks. That idea is really neat. You just roll it up tight, insert it in the worm track, and then let it do its thing. As it expands to fit the shape of the area you put it in, it quickly seals the passage so that you can isolate an area and accurately test it.
- It is best to vacuum test a valve in the regulating position. You can use checkballs, little nuts, end plug clips, etc. instead of trying to hold the valve at the right place with a pick.
- Use the rubber seal expander that comes in the 4L60-E slide seal kit to seal off the balance hole that some valves feature. Sealing the hole helps ensure an accurate vacuum test reading.

**4L60-E Rubber Seal Expander**



## More Free Sonnax "Tech Tools..." Phone, E-mail & Online Tech Support

Whether you prefer talking with somebody live or firing off a typed suggestion or comment, there's many ways to reach the Sonnax tech team. Our skilled technicians are dedicated to working one-on-one with industry professionals on everything from identifying the right parts for problem units and building performance trannies to getting help with reaming and diagnostics.

- Call **(800) 843-2600**
- Visit the Sonnax **Facebook** page
- E-mail **info@sonnax.com** or use the "Contact Us" form at **www.sonnax.com**
- Tweet **@SonnaxVT**
- Look for **Sonnax on industry Web forums**

*Return Service Requested*

## Transmission Report

Volume 6, No. 1

February 2015

### Featured in this issue

**NEW! Webinars & Videos**

**Pressure Switch Kits & Zip Kits<sup>®</sup>**

**Plow Repairs & Upgrades**

Sign up for **Sonnax E-news**

New Products,  
Free Tech Resources,  
Industry Events & More!



Sign Up Today at [www.sonnax.com](http://www.sonnax.com)

### Is this newsletter getting into the right hands?

To update an address or request we stop this mailing to you, please call (800) 843-2600, 8:30 a.m. to 5 p.m. ET, or send an e-mail to [news@sonnax.com](mailto:news@sonnax.com).

Sonnax designs, manufactures, tests and distributes a wide variety of components used to remanufacture torque converters, rebuild automatic transmissions, upgrade driveshafts and protect the driveline from over-torque damage.

**Sonnax is a 100% Employee-Owned Company**

**sonnax**<sup>®</sup>  
**ROADSHOW**



### Coming to a City Near You!

The Sonnax team is traveling across the country in a custom tech van to train rebuilders in the field.

### Work one-on-one with Sonnax experts to learn:

- Transmission troubleshooting
- Vacuum testing diagnostics
- Valve body reaming
- Effective, quality repairs

Want the Roadshow to roll into your town? Let your Sonnax distributor know you're interested! Find event listings at [www.sonnax.com](http://www.sonnax.com) and the Sonnax Facebook page.

**New for 2015**  
**FREE** webinar sessions  
with Steve Garrett!

**GM Gen. 1 6T40/45/50**  
**Concerns & Repair Techniques**  
**March 17 & 18 at noon**



Learn more or register today at [www.sonnax.com](http://www.sonnax.com).

### Details Inside



Watch at  
[www.sonnax.com](http://www.sonnax.com) or  
**You Tube**<sup>™</sup>

### Introduction to Vacuum Testing

New three-part series with Tech Specialist Jim Dial.

### Pressure Switch Installation Demo

TEHCM repairs made easy with Sonnax's patent-pending pressure switch rebuild kits.